



Dear customer

ROHM Co., Ltd. ("ROHM"), on the 1st day of April, 2024,
has absorbed into merger with 100%-owned subsidiary of LAPIS Technology Co., Ltd.

Therefore, all references to "LAPIS Technology Co., Ltd.", "LAPIS Technology"
and/or "LAPIS" in this document shall be replaced with "ROHM Co., Ltd."

Furthermore, there are no changes to the documents relating to our products other than
the company name, the company trademark, logo, etc.

Thank you for your understanding.

ROHM Co., Ltd.
April 1, 2024

MR7930/MR793200

UHF band RFID Sensor LSI

OVERVIEW

MR7930/MR793200 is a passive UHF band RFID Sensor LSI for the battery-less short-range IoT devices.

This LSI is equipped with sensor function to measure electrostatic capacitance.

It is possible to control sensor function by the mandatory command (*READ*, *WRITE*) from Reader/Writer (RW ; interrogator) that is compliant with the international standard EPC global Generation2-Ver.2.0.1 (EPC standard or EPC Gen2). MR7930 is bump wafer product for inlay tag. MR793200 is package product that has SPI slave interface.

FEATURES

- RF communication
 - Carrier frequency : 860 to 960 MHz (UHF band)
 - Data transfer speed
 - RW => Tag : 26.7 to 128 kbps (when the values of data-0 and data-1 are the same)
 - Tag => RW : 40 to 640 kbps
 - Modulation : DSB-ASK, SSB-ASK, PR-ASK
 - Option command : *ACCESS* and *BLOCK WRITE* (data length is one or two words)
- RF communication characteristics
 - Receiver sensitivity (passive)
 - READ* : -9.5 dBm (LSI end)
 - WRITE* : -8.5 dBm (LSI end)
 - READ/WRITE*(Sensor) : -8.5 dBm (LSI end)
 - Reflection coefficient : 0.7 (ASK transmission)
- Memory
 - EPC : 96 bits
 - USER : 144 bits
 - NVM rewrite time : 8ms (16 bits)
 - NVM write endurance : 10,000 cycles
 - NVM data retention : 10 years
- Capacitive sensor
 - Measurement function : Range Max. 100pF
 - Comparison function : Threshold Max. ±1.0pF (Low Range Mode only)
 - Control command : Mandatory command (*READ*, *WRITE*)



MR7930/MR793200

UHF band RFID Sensor LSI

- SPI interface (SPI Slave)
 - Operating frequency : Max. 5 MHz
 - SPI type : 0 or 3
- Interrupt function : It is possible to receive the interrupt notification such as a read request and a write completion from RW to host MCU.
- Arbitration function : It is possible to avoid the collision of access from RW and MCU.
- Shipment

Product name	Shipment	MCU interface	Remark
MR7930-11KDVWJ	Bump wafer	—	Passive
MR793200GD	24pin plastic WQFN	SPI	Passive/Semi-passive

- Guaranteed operation range
 - Operating temperature (ambient) : Ta = -40 to 65 °C
 - Operating voltage : V_{DD} = 1.8 to 3.6 V
- Application
 - Short-range IoT sensor devices
 - Battery-less sensing system
 - Periodic inspection system
 - Logistics • warehouse management system
 - Maintenance and management systems for Infrastructure, Plants, and Buildings

BLOCK DIAGRAM

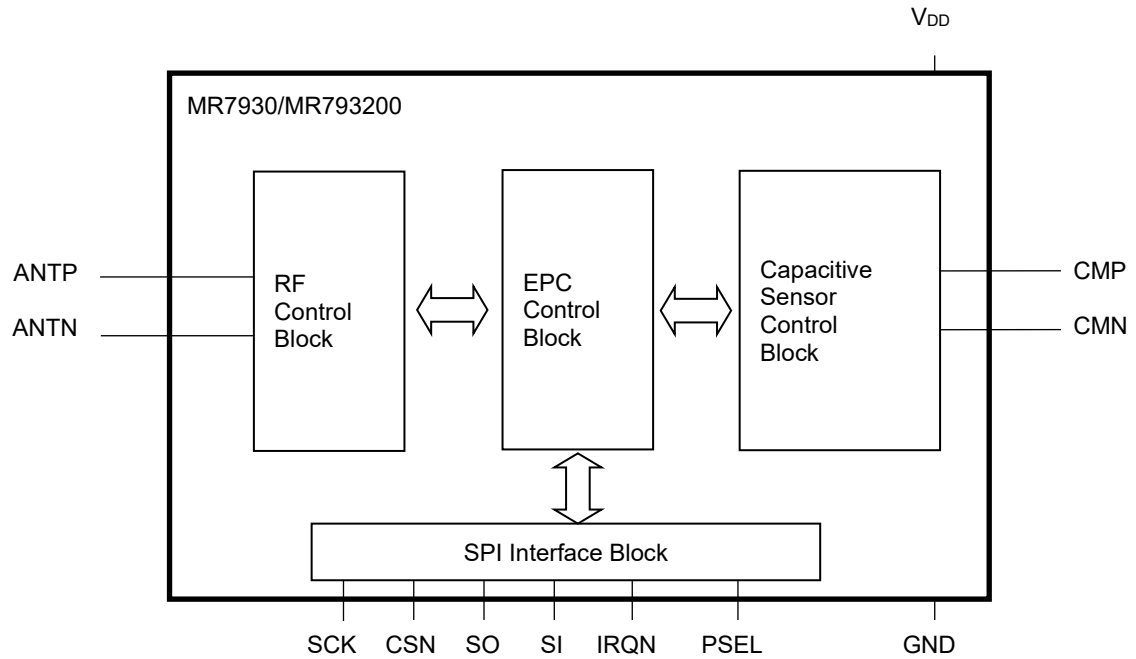

Figure 1 Block Diagram

PIN DESCRIPTION (MR7930)

MR7930 has the 4pads with bumps.

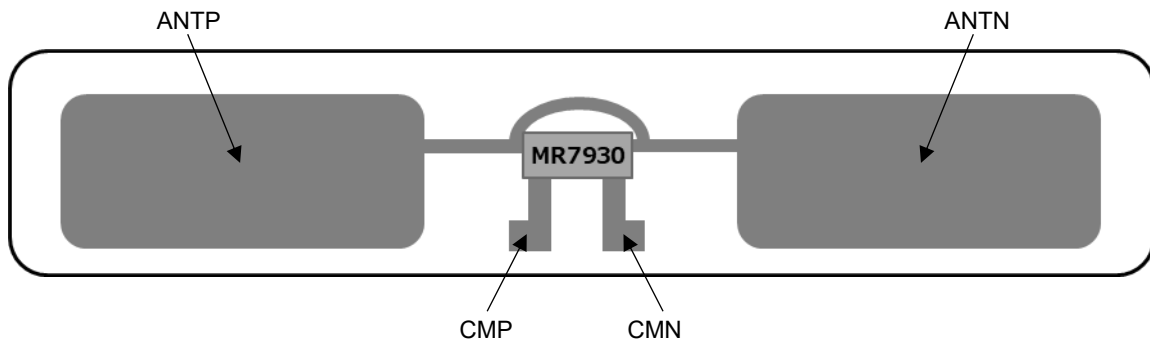

Figure 2 Inlay Image

Table 1 Pin List

Pin name	Description
ANTP	Antenna +pin
ANTN	Antenna -pin
CMP	Capacitive measurement +pin
CMN	Capacitive measurement -pin

PIN ASSIGNMENT (MR793200)

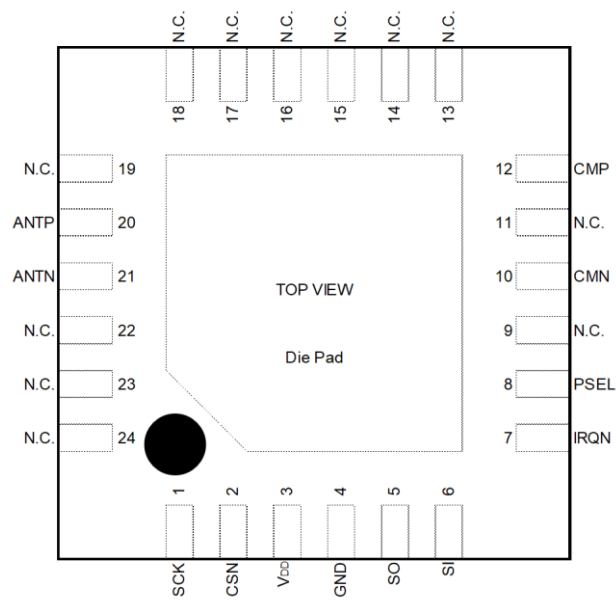

Figure 3 24pin WQFN

PIN DESCRIPTION (MR793200)

Table 2 Pin List (MR793200)

Pin No.	Pin name	I/O	Description	Terminal connection		Initial state (V _{DD} = on)		Active level
				SPI not used (Passive)	SPI used	PSEL = L	PSEL = H	
1	SCK	I	Clock input	Open	Host IF	I-Disable	I-Z	—
2	CSN	I	Chip select input	Open	Host IF	I-Disable	I-Z	L
3	V _{DD}	PI	External power supply	Open	V _{DD}	—	—	—
4	GND	PI	Ground	Open	GND	—	—	—
5	SO	IO	Data output	Open	Host IF	O-Z	O-L	—
6	SI	I	Data input	Open	Host IF	I-Disable	I-Z	—
7	IRQN	O	Interrupt output	Open	Host IF	O-H	O-H	L
8	PSEL	I	External power supply select input ("L" level: RF reception power supply, "H" level: External power supply)	Open	Host IF	I	I	H
9	N.C.	—	Open	Open	Open	—	—	—
10	CMN	A	Capacitive measurement —pin	connection	connection	O-L	O-L	I-A
11	N.C.	—	Open	Open	Open	—	—	—
12	CMP	A	Capacitive measurement +pin	connection	connection	O-L	O-L	I-A
13	N.C.	—	Open	Open	Open	—	—	—
14	N.C.	—	Open	Open	Open	—	—	—
15	N.C.	—	Open	Open	Open	—	—	—
16	N.C.	—	Open	Open	Open	—	—	—
17	N.C.	—	Open	Open	Open	—	—	—
18	N.C.	—	Open	Open	Open	—	—	—
19	N.C.	—	Open	Open	Open	—	—	—
20	ANTP	A	Antenna +pin	Antenna +	Antenna +	I-A	I-A	I-A
21	ANTN	A	Antenna —pin	Antenna -	Antenna -	I-A	I-A	I-A
22	N.C.	—	Open	Open	Open	—	—	—
23	N.C.	—	Open	Open	Open	—	—	—
24	N.C.	—	Open	Open	Open	—	—	—
—	Die Pad	—	Backside ground	Open	GND	—	—	—

I: Input pin, O: Output pin, IO: Input/output pin, A: Analog pin, PI: Power Input

Open: Be sure to keep it open.

O-Z: High-impedance output, O-H: CMOS-H output, O-L: CMOS-L output, I-Disable: Input OFF

I-Z: High impedance input, I-A: Analog input

ELECTRICAL CHARACTERISTICS

● Absolute Maximum Ratings

Item	Symbol	Condition	Rating	Unit
Antenna Input Voltage	V_{max}	ANTP, ANTN	+2.0	V
Digital Input Current	I_{DI}	—	-1 to +1	mA
Digital Output Current	I_{DO}	—	-1 to +1	mA
Antenna Input Power	P_{AB}	—	+10	dBm
Storage Temperature	T_{stg}	—	-40 to +125	°C

● Absolute Maximum Ratings (MR793200)

Item	Symbol	Condition	Rating	Unit
Supply Voltage	V_{DD}	V_{DD} Pin	-0.3 to +4.6	V
Input Voltage	V_{DIN}	—	-0.3 to $V_{DD}+0.3$	V
Output Voltage	V_{DO}	—	-0.3 to $V_{DD}+0.3$	V

● Recommended Operating Conditions

Item	Symbol	Condition	Min.	Typ.	Max.	Unit
Operating Temperature	T_a	—	-40	+25	+65	°C
RF	Operating Frequency	F_{RF}	860	—	960	MHz
	Modulation Depth	(A-B) / A	80	90	100	%
	Reception Bit Rate	F_{rx}	26.7	—	128	kbps
	Power-up Rise Time	T_r	1	—	500	μs
	Power-up Stabilizing Time	T_s	—	—	1,500	μs
	Power-down Fall Time	T_f	—	1	—	500

● Recommended Operating Conditions (MR793200)

Item	Symbol	Condition	Min.	Typ.	Max.	Unit
SPI Supply Voltage	V_{DD}	—	1.8	3.0	3.6	V

● NVM Characteristics

 $T_a = 25^\circ\text{C}$

Item	Symbol	Condition	Min.	Typ.	Max.	Unit
Write Endurance	CYC_{ew}	—	—	10,000	—	Cyc
Data Retention	T_{rtn}	—	—	10	—	Year
Write Time	T_{ew}	1 word = 16 bit	—	7.0	8.0	ms

● RF Communication Characteristics

Ta = 25°C

Item	Symbol	Condition	Min.	Typ.	Max.	Unit
Passive Sensitivity	READ Command	Tari = 25μs, PW = 0.4Tari, RTcal = 3Tari, TRcal = 2.6RTcal, DR = 8, Miller4, BLF = 41kbps, DSB-ASK, Modulation depth = 90%, PSEL = open or L ※at LSI end	—	-9.5	—	dBm
	WRITE Command		—	-8.5	—	dBm
	SENSOR Command		—	-8.5	—	dBm
Semi-passive Sensitivity	READ Command	Tari = 25μs, PW = 0.4Tari, RTcal = 3Tari, TRcal = 2.6RTcal, DR = 8, Miller4, BLF = 41kbps, DSB-ASK, Modulation depth = 90%, PSEL = H, VDD = 3.0V ※at LSI end	—	-20	—	dBm
	WRITE Command		—	-20	—	dBm
	SENSOR Command		—	-20	—	dBm
Maximum Input Power Supply	P _{MAX}	—	—	5	—	dBm
Antenna Input Impedance	C _p	Input power = -10dBm Input frequency = 920MHz ※at LSI end on wafer	—	2	—	pF
	R _p		—	1	—	kΩ
Tag => RW Link Frequency	LF	—	40	—	640	kHz
Tag => RW Link Frequency Tolerance	FT	—	0	—	±22	%

● Capacitive Sensor Characteristics

Ta = 25°C

Item	Symbol	Condition	Min.	Typ.	Max.	Unit
Low Range Mode	Range	—	5	—	25	pF
	Resolution	—	—	0.01	—	pF
	Accuracy	—	—	5	—	%
High Range Mode	Range	—	15	—	100	pF
	Resolution	—	0.02	—	0.20	pF
	Accuracy	—	—	5	—	%
Comparison Function: Threshold (Low Range Mode Only)	—	—	—	—	±1.0	pF

● DC Characteristics (MR793200)

Item	Symbol	Condition	Min.	Typ.	Max.	Unit
High Level Input Voltage (CSN, SCK, SI, PSEL)	V_{IH}	—	$V_{DD} \times 0.7$	—	V_{DD}	V
Low Level Low Voltage (CSN, SCK, SI, PSEL)	V_{IL}	—	0	—	$V_{DD} \times 0.2$	V
High Level Output Voltage (SO, IRQN)	V_{OH}	$I_{OH} = -1\text{mA}$	$V_{DD}-0.6$	—	—	V
Low Level Output Voltage (SO, IRQN)	V_{OL}	$I_{OL} = 1\text{mA}$	—	—	0.4	V
High Level Leakage (CSN, SCK, SI, SO)	I_{IH} I_{OZH}	$V_{IH} = V_{DD}$ or $V_{OH} = V_{DD}$	—	—	1.0	μA
Low Level Leakage (CSN, SCK, SI, SO)	I_{IL} I_{OZL}	$V_{IL} = \text{GND}$ or $V_{OL} = \text{GND}$	-1.0	—	—	μA
Pin Capacitance	C_{IN}	Input pin	—	5	—	pF
	C_{O}	Output pin	—	5	—	pF

● Current Consumption

Ta = 25°C

Item	Symbol	Condition	Min.	Typ.	Max.	Unit
Stand-by 1 (V_{DD})	I_{DS1}	PSEL = L, $V_{DD} = 3.0\text{V}$, RF off	—	0.05	—	μA
Stand-by 2 (V_{DD})	I_{DS2}	PSEL = H, $V_{DD} = 3.0\text{V}$, RF off	—	14	—	μA
Operation (V_{DD})	I_{DO}	PSEL = H, $V_{DD} = 3.0\text{V}$, RF off, SPI Slave 5.0MHz	—	52	—	μA

● AC Characteristics (SPI Slave Interface, MR793200)

$V_{DD} = 1.8$ to $3.6V$, Load capacity = 10 pF

Item	Symbol	Condition	Min.	Typ.	Max.	Unit
SCK Frequency	f_{SCK}	—	0.39	—	5.0	MHz
SCK High Time	t_{SCKWH}	—	80	—	—	ns
SCK Low Time	t_{SCKWL}	—	80	—	—	ns
CSN High Time	t_{CS}	—	600	—	—	ns
CSN Setup Time	t_{CSS}	—	200	—	—	ns
CSN Setup Time	t_{CSH}	—	200	—	—	ns
SI Setup Time	t_{DIS}	—	50	—	—	ns
SI Hold Time	t_{DIH}	—	50	—	—	ns
SO Output Delay Time	t_{PD1}	—	—	—	60	ns
SO Output Hold Time	t_{OH}	—	0	—	—	ns

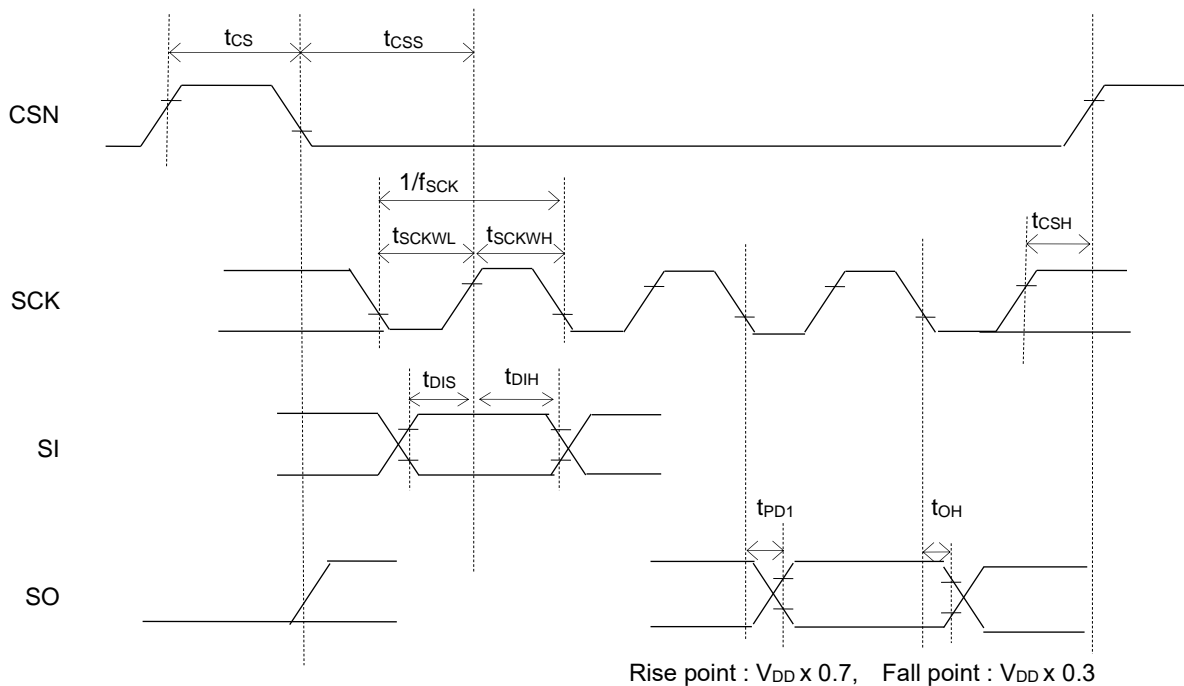

Figure 4 Input / Output and Setup / Hold timing

● External Power Supply Control: When Power-on (SPI Slave Interface, MR793200)

Item	Symbol	Condition	Min.	Typ.	Max.	Unit
V _{DD} Power Rise time※	T _{Vs}	V _{DD} = 1.8V	0.05	—	200	ms
V _{DD} -PSEL Setup Time	T _{PVs}	—	0	—	—	ns
V _{DD} -PSEL Hold Time	T _{PVH}	—	0	—	—	ns
PSEL-CSN Setup Time	T _{WLG}	—	2	—	—	ms

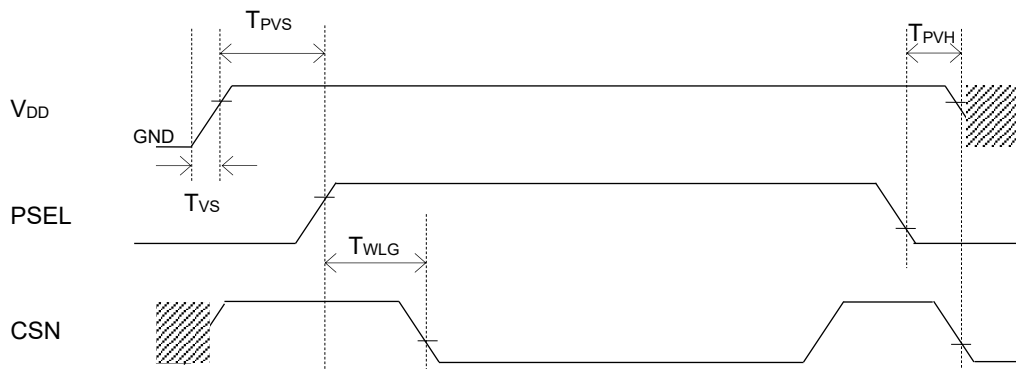

Figure 5 Power-on Sequence

※Set V_{DD} to 1.8V or higher starting from GND (= 0V) level. For other provisions, refer to the user's manual.

MEMOERY MAP

In compliance with the EPC standard, MR7930/MR793200's Memory consists of four banks: Reserved, EPC, TID, and USER. The USER bank consists of a non-volatile memory "NVM" and a volatile memory "RAM". It is possible to control the capacitive sensor functions by accessing "Capacitor monitor1" and "Capacitor monitor2" with *READ* or *WRITE* command.

Also, MR793200 has the SPI slave interface. It is possible to communicate between the host MCU and RW. However, RF (EPC) and SPI have different addresses, so be careful.

The address of RF communication from RW assigns by the EPC column of Table 3.

The address of SPI communication from the host MCU assigns by the SPI column of Table 3.

In addition, MR793200 has a status register for access from the host MCU. For details, refer to the user's manual.

Table 3 Memory Map

EPC		SPI		Access *2	Size (bit)	Description		Initial	
MemBank	Addr	Addr *1							
00	Reserved	h00	h4_00	R/W	32	Kill Password [31:16]		h0000	
		h01	h4_02	R/W		Kill Password [15:0]		h0000	
		h02	h4_04	R/W	32	Access Password [31:16]		h0000	
		h03	h4_06	R/W		Access Password [15:0]		h0000	
01	EPC	h00	h0_0E	R	16	StoredCRC [15:0]		-	
		h01	h4_08	R/W	16	StoredPC [15:0]		h3400 *3	
		h02	h4_0A	R/W	96	EPC		*4	
		h03	h4_0C	R/W					
		h04	h4_0E	R/W					
		h05	h4_10	R/W					
		h06	h4_12	R/W					
		h07	h4_14	R/W					
10	TID	h00	h4_16	R	96	Class ID [7:0]	Mask designer ID [11:4]	hE283	
		h01	h4_18	R		Mask designer ID [3:0]	Model Number [11:0]	MR7930	h3805
		h02	h4_1A	R		XTID [15:0]		h2000	
		h03	h4_1C	R		ID [47:32]		*5	
		h04	h4_1E	R		ID [31:16]			
		h05	h4_20	R		ID [15:0]			
		11	USER (NVM)	h00		h4_22	R/W	144	USER memory
h08	h4_32								
USER (RAM)	h09		h4_34	R/W	32	Sensor mode setting		h0000_0000	
	h0A		h4_36						
	h3C		h6_22	R/W	16	RAM0 FLAG		h0000	
	h42		h6_2E	R/W	16	RAM1 FLAG		h0000	
	h43		h6_30	R/W	16	Capacitor monitor1		h43 ~ h46: h0000 h47 ~ h78: hFFFF h79 ~ h7B: h0000	
	h44		h6_32	R	-	Capacitor monitor2			
h7B	h6_A0								

*1: In the case of read access from SPI to an undefined address, read value is not fixed.

*2: R (Read only), R/W (Read/Write) .

*3: The initial value of StoredPC [15:0] is "b0011_0100_0000_0000".

UMI (StoredPC [10]) is fixed to "1". XI (StoredPC [9]) is fixed to "0".

*4: At shipping test, a value as same as TID data is written in EPC data area.

*5: ID [47:0] is Serial Number.

FUNCTION DESCRIPTIONS

MR7930/MR793200 is equipped with sensor function to measure electrostatic capacitance.

Also, MR793200 has the SPI slave interface. It is possible to communicate between host MCU and RW.

In this session, there are “Supported Command for RF communication”, “Capacitive Sensor Functions (Measurement and Comparison)”, “SPI Slave Interface”, and “Arbitration Function”.

- Supported Commands for RF communication

MR7930/MR793200 supports all mandatory EPC standard commands and some of optional commands as shown in Table 4. It is possible to control sensor function by the mandatory command (*READ*, *WRITE*) from RW.

Table 4 Command List

Classification	Command	Code (binary)
Mandatory	<i>QUERYREP</i>	b00
	<i>ACK</i>	b01
	<i>QUERY</i>	b1000
	<i>QUERYAJUST</i>	b1001
	<i>SELECT</i>	b1010
	<i>NAK</i>	b1100_0000
	<i>REQ_RN</i>	b1100_0001
	<i>READ</i>	b1100_0010
	<i>WRITE</i>	b1100_0011
	<i>KILL</i>	b1100_0100
	<i>LOCK</i>	b1100_0101
Optional	<i>ACCESS</i>	b1100_0110
	<i>BLOCKWRITE</i>	b1100_0111

- Capacitive Measurement Function

MR7930/MR793200 can measure the electrostatic capacitance of the object connected to CMP pin and CMN pin. Capacitive measurement function has two modes. There are “Low Range” and “High Range” as shown in Table 5. It is possible to switch two modes by setting “Sensor mode setting” in the USER bank.

Table 5 Capacitive Measurement Mode

Mode	Resolution	Upper limit	Measurement time (RF communication)	Comparison function
Low Range	10 fF	25 pF	90 ms (BLF = 41kbps)	support
High Range	20 ~ 200 fF	100 pF		no support

Also, it is possible to control the Capacitive Measurement function by accessing “Capacitor monitor2” with *READ* command. The result of Capacitive Measurement is a 12bits binary data. The calculation formula is different for the two modes.

Measurement time is the reference value between *READ* command and sensor data response. (BLF = 41 kbps; Miller4)
For details, refer to the user’s manual.

- Capacitive Comparison Function

MR7930/MR793200 can compare the current capacitance value with the reference value. And it can detect increases and decreases. This function is Low range mode only.

The reference value and Threshold value (increase or decrease) are stored in “Sensor mode setting”.

Also, it is possible to control the Capacitive Comparison function by accessing “Capacitor monitor2” with *READ* command.

The result of Capacitive Comparison function is an 1bit binary data. For details, refer to the user's manual.

● SPI Slave Interface

When PSEL is “H” (Semi-passive mode), MR793200 can use SPI Slave Interface to communicate with the host MCU. As shown in Figure 6, connect the SPI pin (SCK, CSN, SO, SI, IRQN, PSEL) of MR793200 to the host MCU pin (Host IF). It is possible to communicate between host MCU and RW by using USER bank (USER memory, RAM0 FLAG, RAM1 FLAG).

Also, the host MCU can read and write status register of MR793200. For details, refer to the user's manual.

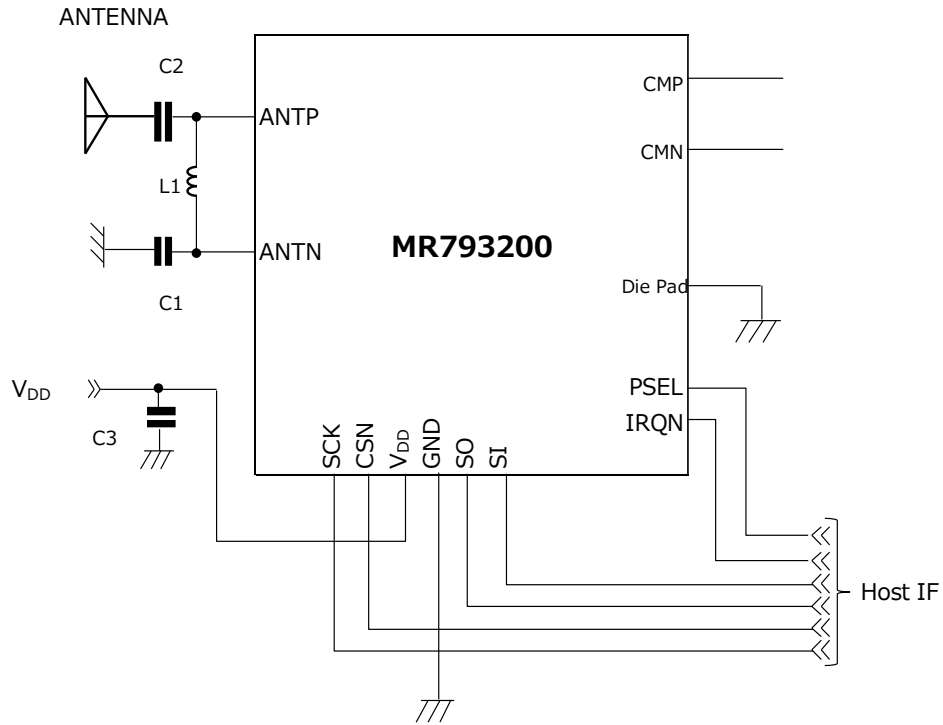

Figure 6 Connection Example with the Host MCU Interface

● Communication Function Usage Conditions

As shown in Table 6, each setting (PSEL, VDD, MCU connection) determines which communication functions are available. For details on the sequence of each communication functions and interrupt factors, refer to the user's manual.

Table 6 Communication Function Usage Conditions

Mode	Usage conditions			Status	Communication function			Product name
	PSEL	V _{DD}	MCU connection		EPC	SPI	Interrupt	
passive	Open	None	None	No battery	Enabled	Disabled	Disabled	MR7930
	Open or "L" level	None	None	No battery or Low battery etc.	Enabled	Disabled	Disabled	MR793200
	"L" level	Supported	Supported	Waiting for an interrupt	Enabled	Disabled	Enabled	
Semi-passive	"H" level	Supported	Supported	SPI communication available	Enabled	Enabled	Enabled	

● Arbitration Function

MR793200 has Arbitration function. It is possible to avoid the collision of access from RW and the host MCU.

As shown in Table 7, SPI_EXCL setting constrains MR793200 Memory Bank's access. SPI_EXCL is a register bit in SPI_STAT (SPI Status Register), and initial value is "0". Also, MR793200's Registers can be set only from the host MCU.

In passive mode, MR7930/MR793200 responds only to RF communication from RW. SPI_EXCL is "0".

In semi-passive mode, MR793200 responds to RF communication from RW and SPI communication from the host MCU.

When SPI_EXCL is set to "0", it is possible to access memory except for writing to NVM area from the host MCU.

If RW and the host MCU access MR793200 at the same time, RF communication will be executed first.

When SPI_EXCL is set to "1", it is possible to access memory by only SPI communication from the host MCU.

Therefore, MR793200 does not accept access from RW. For details, refer to the user's manual.

Table 7 Arbitration Function

Mode	V _{DD}	Command input	SPI_EXCL (register)	Memory access			
				NVM area		RAM area	
				Read	Write	Read	Write
Passive	None	RW (EPC)	0	Enabled	Enabled	Enabled	Enabled
Semi-passive	Supported	RW (EPC)	0	Enabled	Enabled	Enabled	Enabled
			1	Non-response	Non-response	Non-response	Non-response
		MCU (SPI)	0	Enabled	Disabled	Enabled	Enabled
			1	Enabled	Enabled	Enabled	Enabled

ABBREVIATED TERMS

Item	Comment
BLF	Backscatter-Link Frequency
DR	Divide Ratio
DSB-ASK	Double Side Band Amplitude Shift Keying
EPC	Electronic Product Code
EPC standard, EPC Gen2	EPCglobal Class1 Generation2 (Ver.2.0.1)
IoT	Internet of Things
MCU	Micro Controller Unit
N.C.	Non-Connect
NVM	Non-Volatile Memory
PR-ASK	Phase Reversal Amplitude Shift Keying
RAM	Random Access Memory
RFID	Radio Frequency IDentification
RW	Reader-Writer (interrogator)
SPI	Serial Peripheral Interface
SSB-ASK	Single Side Band Amplitude Shift Keying
Tari	Type A Reference Interval
TID	Tag ID
UHF	Ultra High Frequency

REVISION HISTORY

Document No.	Date	Page		Description
		Previous Edition	Current Edition	
FEDM7930-01	Jan. 16, 2023	—	—	1st Edition
FEDM7930-02	Jan. 12, 2024	P.2	P.2	•Product name update •Added applications
		P.18	P.18	•Updated Notes

Notes

- 1) When using LAPIS Technology Products, refer to the latest product information and ensure that usage conditions (absolute maximum ratings*1, recommended operating conditions, etc.) are within the ranges specified. LAPIS Technology disclaims any and all liability for any malfunctions, failure or accident arising out of or in connection with the use of LAPIS Technology Products outside of such usage conditions specified ranges, or without observing precautions. Even if it is used within such usage conditions specified ranges, semiconductors can break down and malfunction due to various factors. Therefore, in order to prevent personal injury, fire or the other damage from break down or malfunction of LAPIS Technology Products, please take safety at your own risk measures such as complying with the derating characteristics, implementing redundant and fire prevention designs, and utilizing backups and fail-safe procedures.
*1: Absolute maximum ratings: a limit value that must not be exceeded even momentarily.
- 2) The Products specified in this document are not designed to be radiation tolerant.
- 3) Descriptions of circuits, software and other related information in this document are provided only to illustrate the standard operation of semiconductor products and application examples. You are fully responsible for the incorporation or any other use of the circuits, software, and information in the design of your product or system. And the peripheral conditions must be taken into account when designing circuits for mass production. LAPIS Technology disclaims any and all liability for any losses and damages incurred by you or third parties arising from the use of these circuits, software, and other related information.
- 4) No license, expressly or implied, is granted hereby under any intellectual property rights or other rights of LAPIS Technology or any third party with respect to LAPIS Technology Products or the information contained in this document (including but not limited to, the Product data, drawings, charts, programs, algorithms, and application examples, etc.). Therefore, LAPIS Technology shall have no responsibility whatsoever for any dispute, concerning such rights owned by third parties, arising out of the use of such technical information.
- 5) LAPIS Technology intends our Products to be used in a way indicated in this document. Please be sure to contact a ROHM sales office if you consider the use of our Products in different way from original use indicated in this document. For use of our Products in medical systems, please be sure to contact a LAPIS Technology representative and must obtain written agreement. Do not use our Products in applications which may directly cause injuries to human life, and which require extremely high reliability, such as aerospace equipment, nuclear power control systems, and submarine repeaters, etc. LAPIS Technology disclaims any and all liability for any losses and damages incurred by you or third parties arising by using the Product for purposes not intended by us without our prior written consent.
- 6) All information contained in this document is subject to change for the purpose of improvement, etc. without any prior notice. Before purchasing or using LAPIS Technology Products, please confirm the latest information with a ROHM sales office. LAPIS Technology has used reasonable care to ensure the accuracy of the information contained in this document, however, LAPIS Technology shall have no responsibility for any damages, expenses or losses arising from inaccuracy or errors of such information.
- 7) Please use the Products in accordance with any applicable environmental laws and regulations, such as the RoHS Directive. LAPIS Technology shall have no responsibility for any damages or losses resulting non-compliance with any applicable laws or regulations.
- 8) When providing our Products and technologies contained in this document to other countries, you must abide by the procedures and provisions stipulated in all applicable export laws and regulations, including without limitation the US Export Administration Regulations and the Foreign Exchange and Foreign Trade Act.
- 9) Please contact a ROHM sales office if you have any questions regarding the information contained in this document or LAPIS Technology's Products.
- 10) This document, in part or in whole, may not be reprinted or reproduced without prior consent of LAPIS Technology.

(Note) "LAPIS Technology" as used in this document means LAPIS Technology Co., Ltd.

Copyright 2023 – 2024 LAPIS Technology Co., Ltd.

LAPIS Technology Co.,Ltd.

2-4-8 Shinyokohama, Kouhoku-ku, Yokohama 222-8575, Japan

<https://www.lapis-tech.com/en/>