



Dear customer

ROHM Co., Ltd. ("ROHM"), on the 1st day of April, 2024,
has absorbed into merger with 100%-owned subsidiary of LAPIS Technology Co., Ltd.

Therefore, all references to "LAPIS Technology Co., Ltd.", "LAPIS Technology"
and/or "LAPIS" in this document shall be replaced with "ROHM Co., Ltd."

Furthermore, there are no changes to the documents relating to our products other than
the company name, the company trademark, logo, etc.

Thank you for your understanding.

ROHM Co., Ltd.
April 1, 2024

ML7386/7386B

Sub GHz band wireless transmitter IC

■ Overview

ML7386/ML7386B are a low power RF transmitter IC for narrowband system. It includes RF part, MOD part and HOST interface part in single-chip. It supports various frequency band from 200 MHz to 972 MHz. It is possible to use as wireless alarm and security systems, low power telemetry and industrial remote control systems.

ML7386 supports only 10mW mode. ML7386B supports both 10mW and 1mW mode.

- Product Name ML7386GD ML7386BGD
- Application Remote control
 Home, Building Security
 Sensor Network

■ Features

- Support 200 MHz to 972 MHz operation. (*1)
- Support narrow band systems with channel spacing of 12.5 or 25 kHz
- High accurate modulation implemented by direct modulation scheme using fractional-N PLL
- Multiple modulation scheme : 2-FSK/MSK
- Data speed : 2400/4800/7200 bps (NRZ coding)
 - Extended data rate function can set 1.2kbps to 100kbps (NRZ coding) (*1)
- Supports NRZ code and Manchester code
 - In case of using Manchester code, DCLK frequency becomes half to NRZ coding case.
- Programmable frequency deviation: $\pm 0.6\text{kHz}$ to $\pm 100\text{kHz}$ (*1)
- Configurable data polarity
- On chip oscillation cell: 16MHz to 36MHz (*1)
- Support direct input from TCXO: 16MHz to 36MHz (*1)
- Frequency trimming function (Fractional-N PLL architecture enables fine tuning of synthesizer frequency)
- Synchronous serial peripheral interface (SPI)
- Built in voltage regulated Power Amp (PA) and power control function
 - ML7386 supports 10mW mode only
 - ML7386B supports 10mW and 1mW mode.
- Test Pattern generation (PN9, CW, 0/1, all-1, all-0 pattern)
- Power supply voltage : 2.0 V to 3.6V (10mW mode)
 - 1.8 V to 3.6V (1mW mode)
- Operating temperature -40 to +85 °C
- Power consumption (tentative)

Deep Sleep Mode	0.03 uA (Typ.) (Register non-retain)
Sleep Mode	0.3 uA (Typ.) (Register retain)
Idle Mode	0.25 mA (Typ.) (Oscillator cell OFF)
Stop Mode	1.0 mA (Typ.) (Transmitter OFF)
TX (10mW)	23.8 mA (Typ.) (TCXO mode)
TX (1mW)	6.4 mA (Typ.) (TCXO mode)
- Package
 - 28 pin WQFN 4.0mm x 4.0mm x 0.8mm
 - Pb free, RoHS compliant



*1: These specifications show the setting range base on the ML7386 and ML7386B function.
 Performance is guaranteed under the condition specified in “Performance guarantee condition”

ML7386/7386B

Sub GHz band wireless transmitter IC

If using ML7386 and ML7386B under the condition not specified in “Performance guarantee condition”, evaluation and confirmation should be required under user specific condition.

■Description Convention

1) Numbers description

'0xnn' indicates hexadecimal and '0bnn' indicates binary

Example: 0x11=17 (decimal), 0b11=3 (decimal)

2) Register description

[<register name>: <register address>] register

Example: [RF_MODE: 0x00] register

Register name: RF_MODE

Register address: 0x00

3) Bit name description

<bit name> ([<register name>: <register address> (<bit location>)])

Example: txtest_en([TXD_SEL: 0x02(3)])

Bit name: test_en

Register name: TXD_SEL

Register address: 0x02

Bit location: bit3

■PIN Assignment

28 pin WQFN

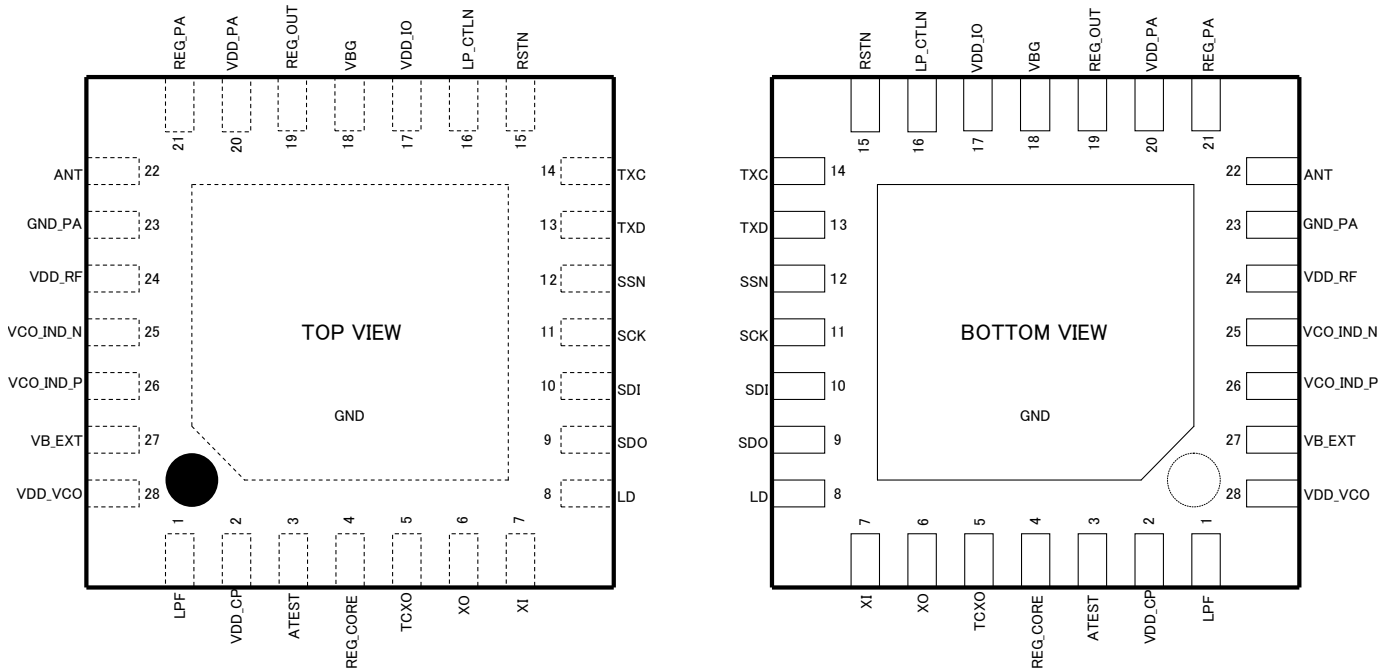

Fig.2 PIN ASSIGNMENT

NOTE: Pattern shown in the centre of the chip is located at bottom side of the chip (GND PAD)

■PIN Definitions

Symbols

I_{RF}	: RF input
O_{RF}	: RF output
I_A	: Analog input
I_{OSc}	: Oscillator input
O_{OSc}	: Oscillator output
I	: Digital input
O	: Digital output
I_s	: Schmitt Trigger input

●RF / Analog pins

Pin No	Pin name	I/O	Active Level	at reset	Detail function
1	LPF	I_{RF}	-	-	PLL loop filter pin
3	AATEST	O_{RF}	-	O	Analog test output
22	ANT	O_{RF}		O	RF signal output to antenna
25	VCO_IND_N	-	-	-	Pin for external inductor of VCO
26	VCO_IND_P	-	-	-	Pin for external inductor of VCO
38	VB_EXT	-	-	-	External capacitor pin for local oscillator stability

●SPI interface pins

Pin No	Pin name	I/O	Active Level	at reset	Detail function
9	SDO	O	-	L	SPI data output
10	SDI	I	-	I	SPI data input
11	SCK	Is	P	I	SPI clock input SDI is captured at rising edge SDO is output at falling edge
12	SSN	Is	L	I	SPI enable input

●TX data interface pins

Pin No	Pin name	I/O	Active Level	at reset	Detail function
13	TXD	I	-	I	TX data input
14	TXC	O	P	L	TX clock output TXD is captured at rising edge

●Regulator pins

Pin No	Pin name	I/O	Active Level	at reset	Detail function
4	REG_CORE	-	-	-	Monitor pin for power supply to digital core (typ.1.5V) Connection for external capacitor with 10uF
18	VBG	-	-	-	Back bias pin. Connection for external capacitor with 0.1 μF.
19	REG_OUT	-	-	-	Regulator output (typ.1.5V) Connection for external capacitor with 6.8 μF
21	REG_PA	-	-	-	Regulator output for PA. (1.5V to 2.0V) Connection for external capacitor with 1 uF.

●Miscellaneous

Pin No	Pin name	I/O	Active Level	at reset	Detail function
5	TCXO	I _A	-	I	External clock (TCXO) input pin. *Fixed to GND level when crystal oscillator is used.
6	XO	Oosc	-	O	26MHz oscillator pin2 *Fixed to GND level when external clock generator is used
7	XIN	Iosc	-	I	26MHz oscillator pin1 *Fixed to GND level when external clock generator is used
8	LD *1	O	H	L	PLL Lock detect pin L: PLL unlock status H: PLL lock status
15	RSTN	Is	L	I	Hardware reset L: Rest, stop H: Normal operation
16	LP_CTLN	I	L	I	Sleep mode control pin L: Deep sleep mode H: Exit from deep sleep mode

*1 Activated when write 0x18 to the [RF_MODE: 0x00] register.

●Power Supply

Pin No	Pin name	I/O	Active Level	at reset	Detail function
2	VDD_CP	-	-	-	Power supply pin for PLL charge pump block. (Connection for REG_OUT pin. Typ.1.5V)
17	VDD_IO	-	-	-	Power supply for digital IOs (Input voltage from 1.8 V to 3.3 V)
20	VDD_PA	-	-	-	Power supply pin for PA block. (Input voltage from 1.8V to 3.3V)
23	GND_PA	-	-	-	GND pin for PA block.
24	VDD_RF	-	-	-	Power supply pin for RF blocks. (Connection for REG_OUT pin. Typ.1.5V)
28	VDD_VCO	-	-	-	Power supply pin for VCO block. (Connection for REG_OUT pin. Typ.1.5V)

●Unused pins

Followings are recommendation for unused pins

Pin Name	Recommendation
XO	Fixed to GND (When TCXO is used)
XI	Fixed to GND (When TCXO is used)
TCXO	Fixed to GND (When Crystal OSC is used)
ATEST	Left OPEN

[Note]

If input pins are high-impedance state and leave open, excess current could be drawn. Care must be taken that unused input pins and unused I/O pins should not be left open.

■Electrical Characteristics

●Absolute Maximum Ratings

Item	Symbol	Condition	Rating	Unit
Power Supply (I/O) (*1)	V _{DDIO}	Ta=-40 to 85°C GND=0V	-0.3 to +4.6	V
Power Supply (RF) (*2)	V _{DDRF}		-0.3 to +2.0	V
Digital Input Voltage	V _{DIN}		-0.3 to V _{DDIO} +0.3	V
RF Input Voltage	V _{RFIN}		-0.3 to V _{DDRF} +0.3	V
Analog Input Voltage	V _{AIN}		-0.3 to V _{DDIO} +0.3	V
Analog Input Voltage2 (*3)	V _{AIN2}		-0.3 to V _{DDRF} +0.3	V
Digital Output Voltage	V _{DO}		-0.3 to V _{DDIO} +0.3	V
RF Output Voltage	V _{RFO}		-0.3 to V _{DDRF} +0.3	V
Analog Output Voltage	V _{AO}		-0.3 to V _{DDIO} +0.3	V
Analog Output Voltage2 (*4)	V _{AO2}		-0.3 to V _{DDRF} +0.3	V
Digital Input Current	I _{DI}		-10 to +10	mA
RF Input Current	I _{RF}		-2 to +2	mA
Analog Input Current	I _{AI}		-2 to +2	mA
Analog Input Current2 (*3)	I _{AI2}		-2 to +2	mA
Digital Output Current	I _{DO}		-10 to +10	mA
RF Output Current	I _{RFO}		-2 to +2	mA
Analog Output Current	I _{AO}	-2 to +2	mA	
Analog Output Current2 (*4)	I _{AO2}	-2 to +2	mA	
Power Dicipatin	P _d	Ta=+25°C	500	mW
Storage Temperature	T _{stg}	-	-55 to +125	°C

(*1) VDD_IO, VDD_PA pins

(*2) VDD_RF, VDD_VCO, VDD_CP pins

(*3) XI pins

(*4) XO pin

●Recommended Operating Conditions

Item	Symbol	Conditions	Min	Typ	Max	Unit
Power Supply (I/O)	V _{DDIO}	VDD_IO, VDD_PA pins	1.80	2.70	3.60	V
Power Supply (RF)	V _{DDRF}	VDD_RF, VDD_VCO, VDD_CP pins	1.45	1.50	1.55	V
RF characteristic temperature	T _a	-	-25	+25	+85	°C
Operating Temperature	T _a	-	-40	+25	+85	°C
Rising time Digital Input	T _{IR1}	Digital input pins (*1)	–	–	20	ns
Falling time Digital Input	T _{IF1}	Digital Input pins (*1)	–	–	20	ns
Output loads Digital Output	C _{DL}	All Digital Output pins	–	–	50	pF
Master Clock1	F _{MCK1}	XIN, XOUT pins (*2)	-4ppm	26	+4ppm	MHz
Master Clock2	F _{MCK2}	TCXO pin (*2)	-4ppm	26	+4ppm	MHz
TX clock Output	F _{CLKOUT}	TXC pin	-400ppm -200ppm -200ppm	7200 4800 2400	+400ppm +200ppm +200ppm	Vpp
SPI clock frequency	F _{SCLK}	SCLK pin	0.1	2	8	MHz
SPI clock duty ratio	D _{SCLK}	SCLK pin	45	50	55	%
RF frequency	F _{RF1}	ANT pin 12.5kHz channel spacing	426.2500	–	426.8375	Mhz

(*1) Those pines with symbol I or Is at I/Ocolumn in the Pin Definition section

(*2) Minimum and maximum limit are defined in standards. Please refer standards, i.e ARIB STD-T67, RCR STD-30 and so on.

●Power Consumption

(Condition: VDDIO=1.8V to 3.6V, Ta=-40°C to +85°C, Fmck=26MHz)

Item	Symbol	Conditions	Min	Typ (*2)	Max	Unit
Power Consumption (*1)	I _{DDS1}	Deep Sleep state (Registers are not retained)	–	0.03	15.0	μA
	I _{DDS2}	Sleep state (Registers are retained)	–	0.3	30.0	μA
	I _{DD1}	Idle state (*3) (OSC circuit OFF, RF OFF)	–	0.25	1.5	mA
	I _{DD2}	Stop state (OSC circuit ON, RF OFF)	–	0.65	3.0	mA
	I _{DD3}	TX state (10mW) (*4), (*5)	–	23.8	52.0	mA
	I _{DD4}	TX state (1mW) (*4), (*5)	–	6.4	20.0	mA

(*1) Power consumption is sum of current consumption of all power supply pins

(*2) “Typ” value is centre value under condition of VDDIO=2.7V, 25 °C .

(*3) If using SPI access with 8 MHz speed, specified current is added to the each value.

(*4) SPI access speed is 2 MHz and data transmission speed at 4800 bps

(*5) In case of using TCXO. In case of using crystal, adding 0.3mA under the typical condition.

●DC Characteristics

(Condition: VDDIO=1.8V to 3.6V, VDDR1=1.45V to 1.55V, Ta=-40°C to +85°C, Fmck=26MHz)

Item	Symbol	Conditions	Min	Typ (*2)	Max	Unit
Voltage Input High	VIH1	(*1), (*2)	VDDIO * 0.77	–	VDDIO	V
	VIH2	XI pin	VDDRF * 0.9	–	VDDRF	V
Voltage Input Low	VIL1	(*1), (*2)	0	–	VDDIO * 0.18	V
	VIL2	XI pin	0	–	VDDRF * 0.10	V
Input Voltage	VI	TCXO pin	0.8	–	VDDRF	Vp-p
Threshold Voltage High level	VT+	(*2)	–	1.2	VDDIO * 0.77	V
Threshold Voltage Low level	VT-	(*2)	VDDIO * 0.18	0.8	–	V
Input Leakage Current	IIH1	VIH = VDDIO (*1), (*2)	-2	–	2	μA
	IIL1	VIL = 0 V (*1), (*2)	-2	–	2	μA
Voltage Output level H	VOH	IOH=-4 mA (*3)	VDDIO * 0.78	–	VDDIO	V
Voltage Output level L	VOL	IOL= 4 mA (*3)	0	–	0.3	V
Regulator output voltage	REG_CORE	Sleep state	–	1.3	–	V
		Other states	–	1.5	–	V
	REG_OUT	Exclude sleep state	–	1.5	–	V
Input Capacitance	CIN	Input pins (*1),(*2)	–	6	–	pF
	COUT	Output pins (*3)	–	9	–	pF
	CRFI	RF input pins (*4)	–	9	–	pF
	CRFO	RF output pins (*5)	–	9	–	pF
	CAI	Analog input pins (*6)	–	9	–	pF

(*1) Pins with symbol I at the I/O column in the Pin Definitions section

(*2) Pins with symbol Is at the I/O column in the Pin Definitions section

(*3) Pins with symbol O at the I/O column in the Pin Definitions section. XO pin is excluded

(*4) Pins with symbol I_{RF} at the I/O column in the Pin Definitions section(*5) Pins with symbol O_{RF} at the I/O column in the Pin Definitions section(*6) Pins with symbol I_A at the I/O column in the Pin Definitions section

●RF Characteristics

[Performance guarantee condition]

Data Rate	: 2400 bps / 4800 bps / 7200 bps
Modulation scheme	: 2-FSK/MSK
Channel spacing	: 12.5 kHz / 25.0 kHz
Frequency	: 426.0250 MHz to 426.8375MHz
Power supply	: 1.8V to 3.6V (unless specifying alternate condition)
Temperature	: -25°C to 85 °C (unless specifying alternate condition)
Master clock	: 26 MHz (unless specifying alternate condition)

[Start up time]

Item	Condition	Min	Typ	Max	Unit
Regulator start up time	LP_CTLN = H	-	600	1500	μs
Crystal oscillator start up time (*1)	26 MHz	-	715	1115	μs
TX start up time (*2)	PLL and PA start up time (TCXO mode :IDLE mode) (OSC mode :STOP mode)	-	1460	1600	μs
PLL lock up time (*3)	frequency change in TX state	-	50	100	μs

[Transmitter performance]

Item	Condition	Min	Typ	Max	Unit
TX Power (10 mW mode) (*4)	[PA_ADJ:0x10]=0xnn	5	-	12	mW
TX Power (1 mW mode) (*4), (*7)	[PA_ADJ: 0x10]=0xnn [PA_BIAS:0x16]=0xnn	0.5	-	1.2	mW
Adjacent Channel Power Ratio [ACPR] (*5)	±12.5kHz offset ± 4.25 kHz bandwidth 4800 bps, Fdev=2.1 kHz		-48	-40	dBc
Occupied bandwidth [OBW]	99%, 4800 bps, Fdev=2.1 kHz	4.0	-	8.5	kHz
Frequency deviation range (*6)		±0.6	-	±4.2	kHz
Modulation index	MSK 4800 bps, Fdev=1.2 kHz	0.49	0.50	0.51	-
Spurious emission radiated CW	10mW output	-	-32	-26	dBm
Adjacent spurious emission	PN9, 10mW output ±112.5kHz offset ± 50 kHz bandwidth 4800 bps, Fdev=2.1 kHz	-	-32	-26	dBm

(*1) The time to output rectangular clock from oscillation circuit into the stable counter from setting STOP mode (0x10) to [RF_MODE:0x00] register. After counting 0x1FFF, the oscillation block output to internal circuits and enable to start TX operation.

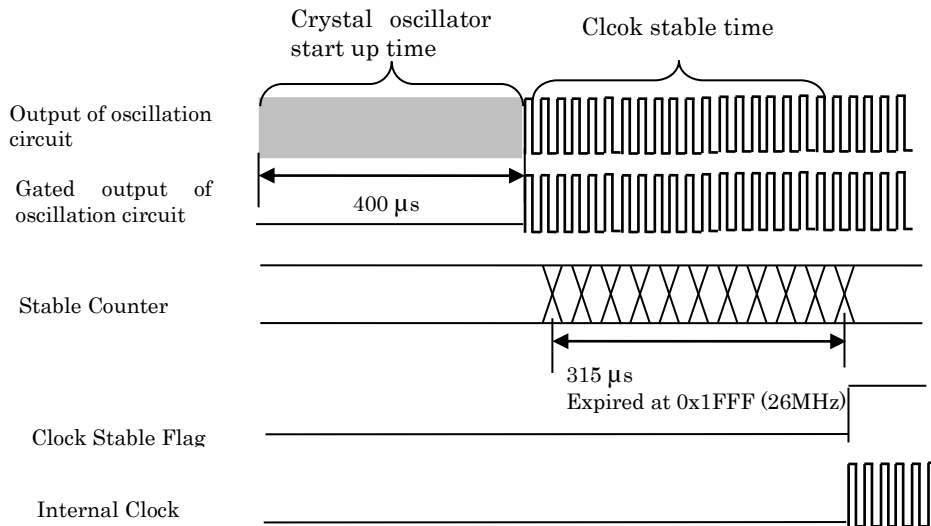

(*2) The time to converge in ± 10 kHz of PLL frequency from setting ACT mode (0x18) into [RF_MODE:0x00] register. LD pin will rise before PLL is converged.

(*3) When in operating F0 with TX state, the transition time to converge in ± 10 kHz in PLL frequency (F1).

(*4) Fine adjustment of PA_ADJ value is required because of variation of external components or PCB. Output power may be varied depending on temperature or power supply variation. It is recommended to adjust [PA_ADJ:0x10] register in order to meet required power. (*5) ACPR performance is result after adjusting channel frequency within ± 0.25 ppm accuracy.

(*6) Frequency deviation range and RF channel frequency are showing possible range, it is not guaranteed the all performance described in this data sheet.

(*7) 1mW mode is applied to ML7386B only.

■Timing Characteristics

●SPI interface

(Condition: VDDIO=1.8V to 3.6V, Ta=-40°C to +85°C)

Item	Symbol	Condition	Min	Typ	Max	Unit
SCLK clock frequency	F_SCLK	Load capacitance CL=20pF	0.1	2	8	MHz
SSN input setup time	T _{SSNSU}		125	–	–	ns
SSN input hold time	T _{SSNH}		20	–	–	ns
SCK high pulse width	T _{WSCKH}		56	–	–	ns
SCK low pulse width	T _{WSCKL}		56	–	–	ns
SDI input setup time	T _{SDISU}		5	–	–	ns
SDI input hold time	T _{SDIH}		15	–	–	ns
SSN assert interval	T _{SSNAI}		125	–	–	ns
SDO output delay	T _{SDOH}		SCK high pulse width	–	–	SCK 1 clock

NOTE: All timing parameter is defined at voltage level of V_{DDIO} * 20% and V_{DDIO} * 80%.

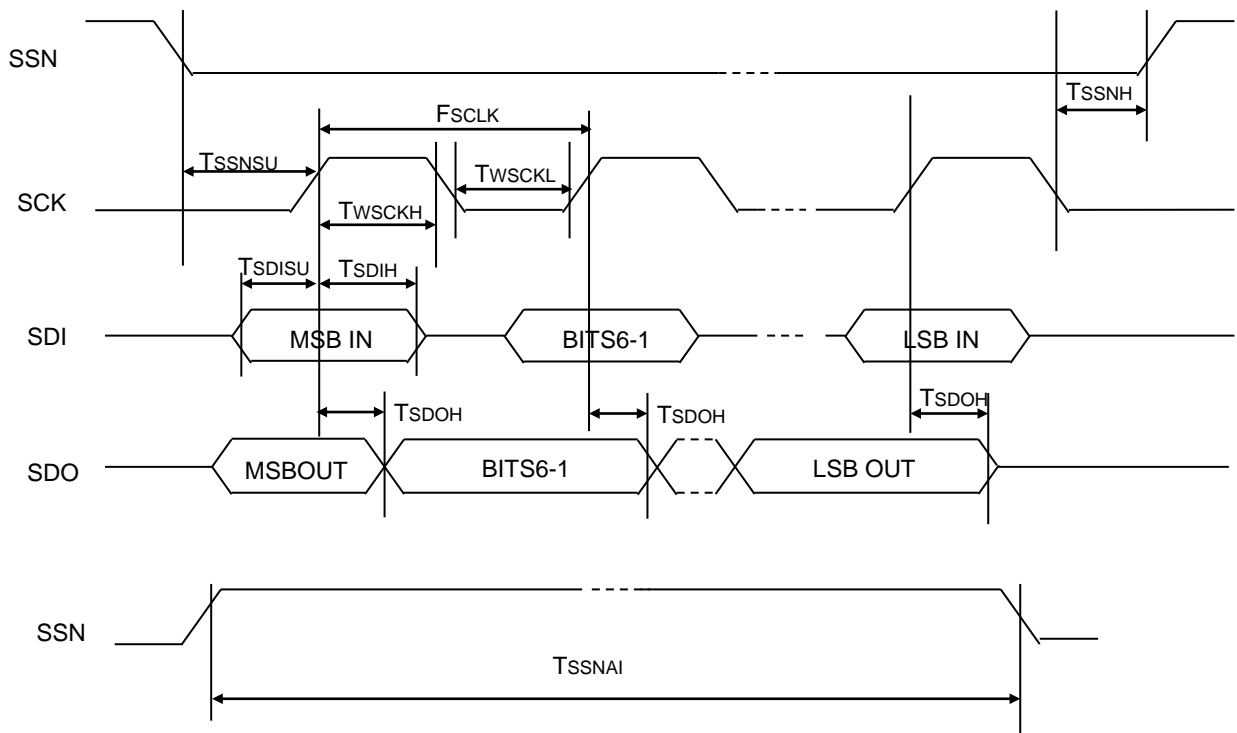

SCK has to be “L” when it is not active.

SPI Data format

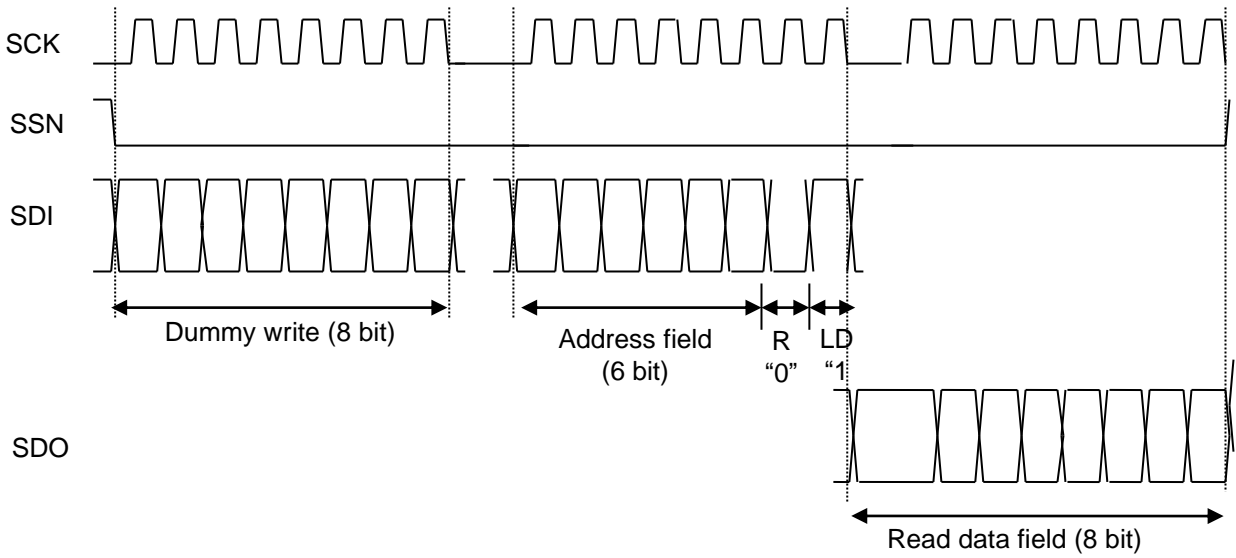
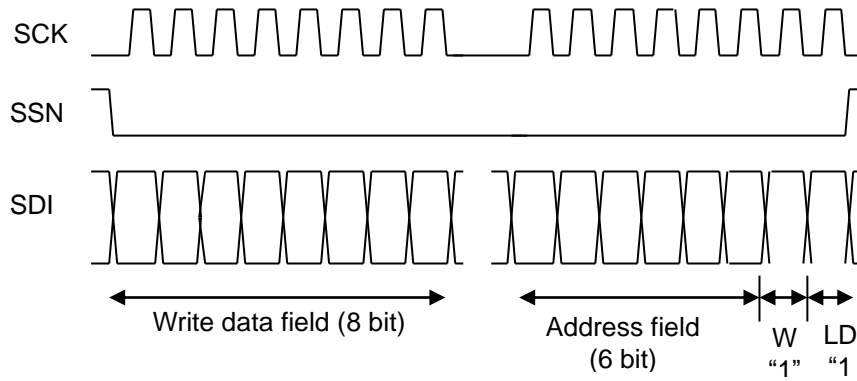

●TX Data interface

(Condition: VDDIO=1.8V to 3.6V, Ta=-40°C to +85°C)

Item	Symbol	Condition	Min	Typ	Max	Unit
TXD Input setup time	T _{DISU}	Load capacitance CL=50pF	5	-	-	μs
TXD Input hold time	T _{DIH}		5	-	-	μs
TXC clock frequency	F _{DCLK}		-400 ppm -200 ppm -200 ppm	7200 4800 2400	+400 ppm +200 ppm +200 ppm	kHz

NOTE: All timing parameter is defined at voltage level of V_{DDIO} x 20% and V_{DDIO} x 80%.

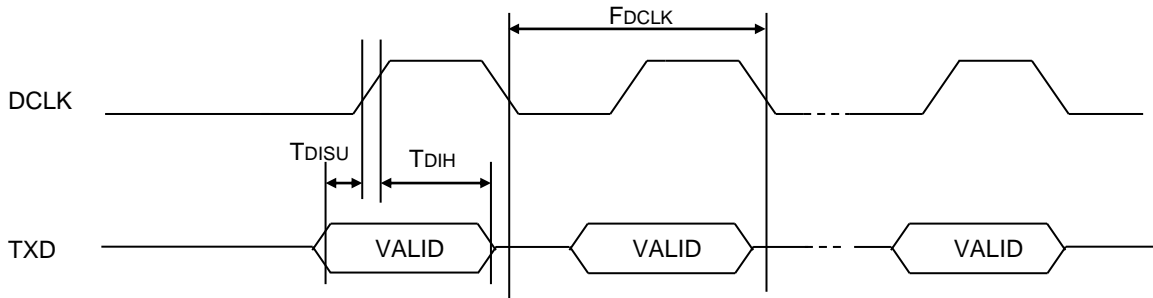

[Delay timing of demodulated RF signal]

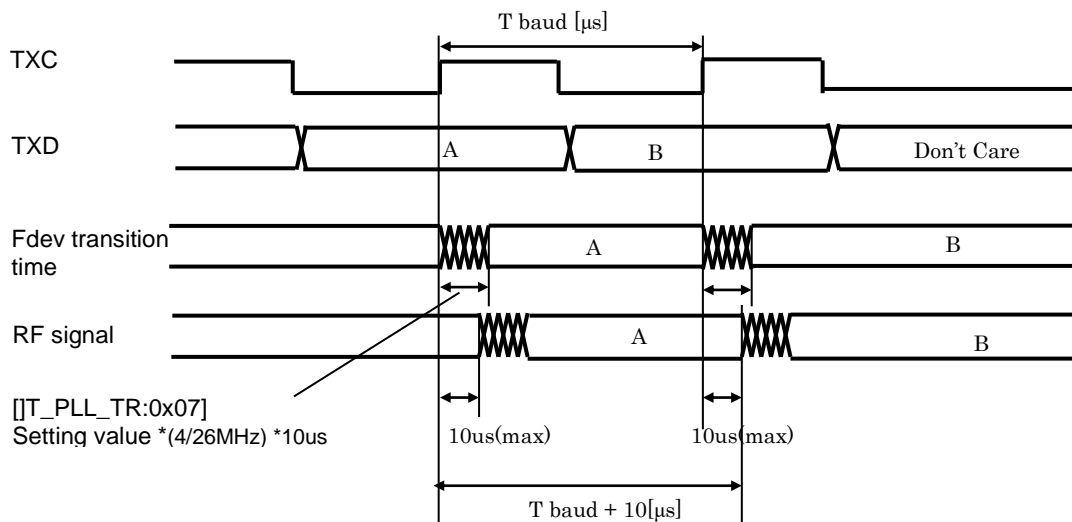

[Note]

After data input is end at TX data interface, valid RF signal is still transmitting due to demodulation delay. When transit from ACT mode by [RF_MODE: 0x00] register, this delay timing should be considered.

●Power ON

(Condition: VDDIO=1.8V to 3.6V, Ta=-40°C to +85°C)

Item	Symbol	Condition	Min	Typ	Max	Unit
RESETN delay time (Power on)	TRDL	All power supply pins (After power on)	1.6	-	-	ms
RESETN assert time (pulse width)	TRPLS		200	-	-	ns
LP_CNLN delay time (Power on)	TLDL	All power supply pins (After power on)	100	-	-	μs
LP_CTLN rising time	TLRH	VDD="H"	1.5	-	-	ms

NOTE: All timing parameter is defined at voltage level of VDDIO * 20% and VDDIO * 80%.

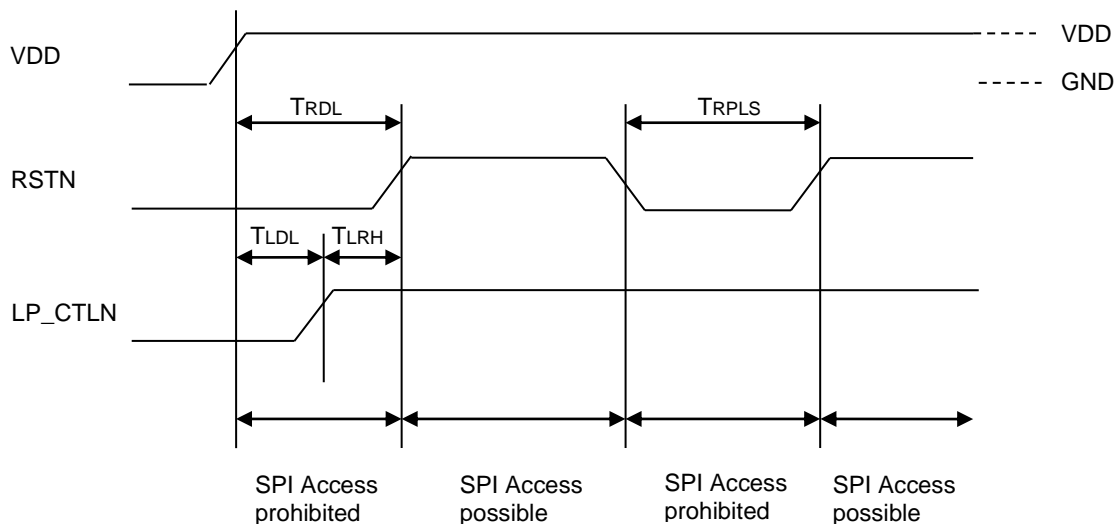

[Note]

The I/O state of the digital pins are undefined during LP_CTRN=L.

●Low Power Control interface

(Condition: VDDIO=1.8V to 3.6V, Ta=-40°C to +85°C)

Item	Symbol	Condition	Min	Typ	Max	Unit
LP_CTLN falling time	T _{LRL}	VDD="H"	0	—	—	μs
LP_CTLN pulse width	T _{LPLS}	VDD="H"	1200	—	—	μs
LP_CTLN rising time	T _{LRH}	VDD="H"	1.5	—	—	ms

NOTE: All timing parameter is defined at voltage level of V_{DDIO} * 20% and V_{DDIO} * 80%.

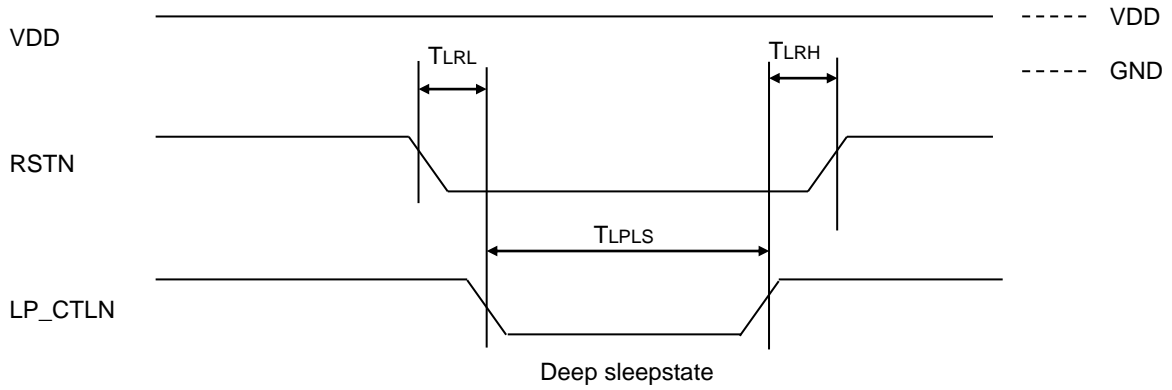

●State Transition

ML7386/ML7386B has 5 operating modes. Except for Deep Sleep state, state transition is available by [RF_MODE: 0x00] register.

- Deep Sleep state: Shut down the LSI and current consumption is minimum.
- Sleep state: Retain register values and minimized current consumption.
- Idle state: Register access is available and oscillation circuit is off state.
- Stop state: Register access is available and oscillation circuit is on state.
- ACT state: RF circuit is on state.

Block condition in each state is shown as below table.

State	Registers	SPI Access	Oscillation Circuit	RF Circuit	Current (Typ.)
Deep Sleep	Not Retain	Not available	OFF	OFF	0.03μA
Sleep	Retain	Not available (*1)	OFF	OFF	0.3μA
Idle	Retain	Available	OFF	OFF	0.25mA
Stop	Retain	Available	ON	OFF	0.65mA
Act	Retain	Available	ON	ON	23.8mA(10mW) 6.4mA (1mW)

*1: In the Sleep state, only the Idle state transition command is acceptable.

[State Diagram]

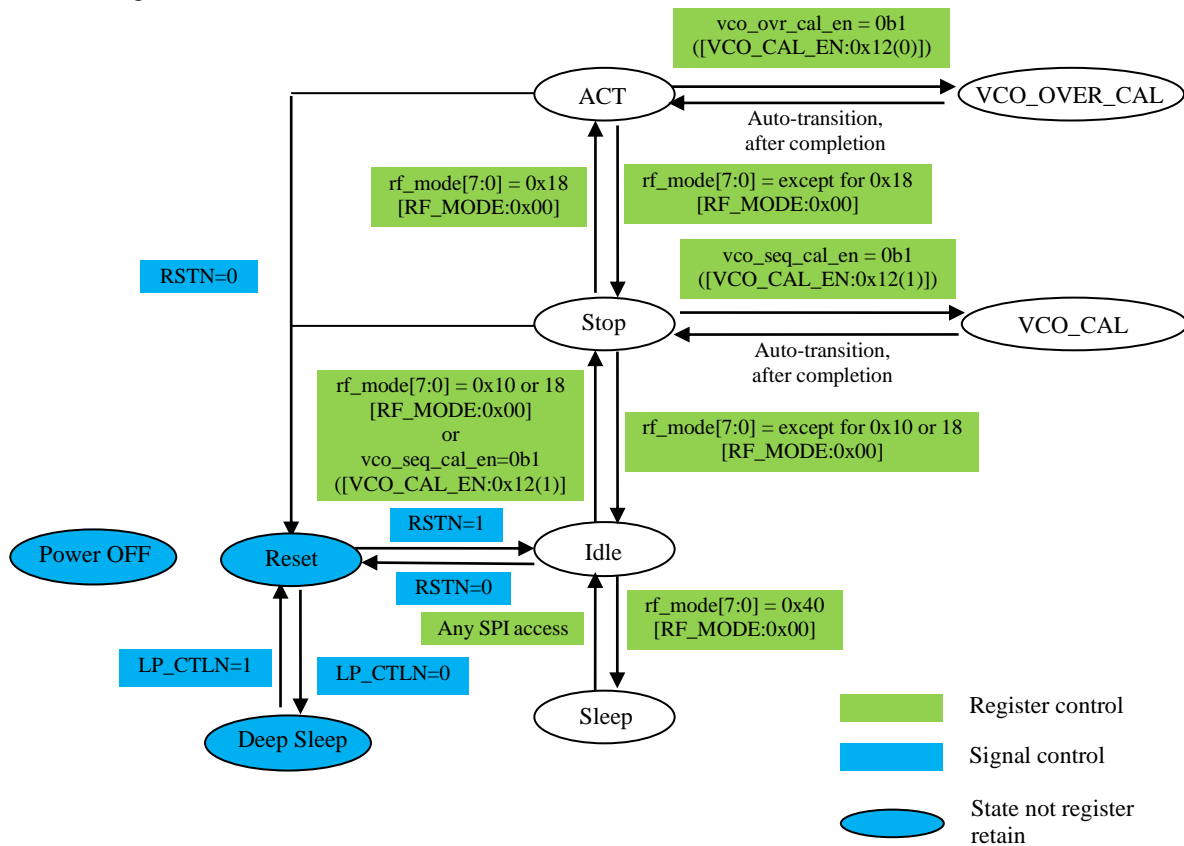

Required wait time at each state transition is shown as below table.

No.	Current state	State to be moved	Possibility	rf_mode[7:0] [RF_MODE:0x00]	Required Wait Time [ms] (*2)
1	Sleep	Idle	O	0x00	1.5
2	Sleep	Stop	O	0x10	2.3
3	Sleep	ACT	X (*1)	-	-
4	Idle	Sleep	O	0x40	0.1
5	Idle	Stop	O	0x10	0.8
6	Idle	ACT	O	0x18	2.715
7	Stop	Sleep	O	0x40	0.1
8	Stop	Idle	O	0x00	0.1
9	Stop	ACT	O	0x18	1.6
10	ACT	Sleep	O	0x40	0.12
11	ACT	Idle	O	0x00	0.1
12	ACT	Stop	O	0x10	0.1

*1: The state transition from Sleep state to ACT state is prohibited. Once Idle transition is necessary.

In this case, total transition time 1.5ms + 2.715ms = 4.215ms

*2: During the waiting time, [RF_MODE:0x00, [CLK_SEL:0x0E]and [VCO_CAL_EN:0x12] register accesses are prohibited.

[Off to Idle]

The following shows the operation timing from power off state to Idle state.

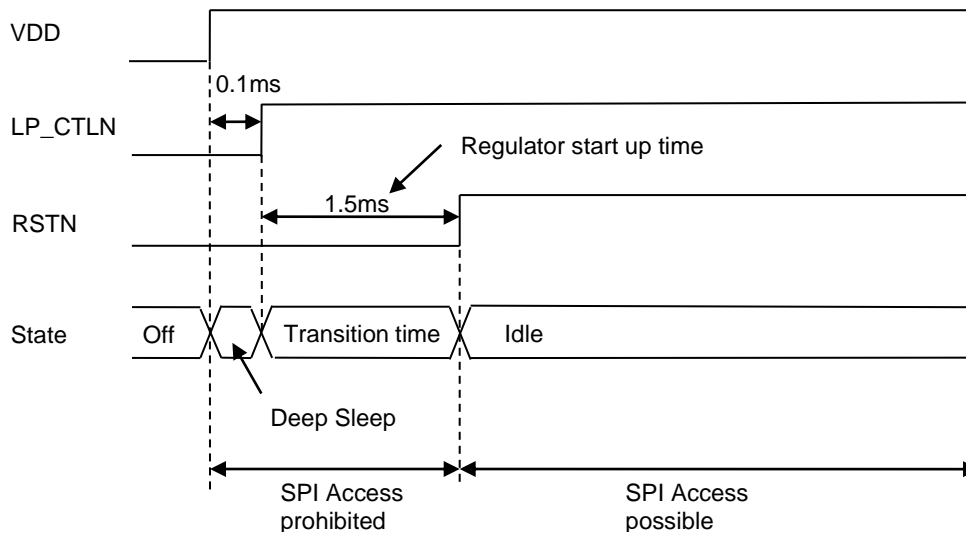

[Sleep to Idle]

The following shows the operation timing from sleep state to Idle state.

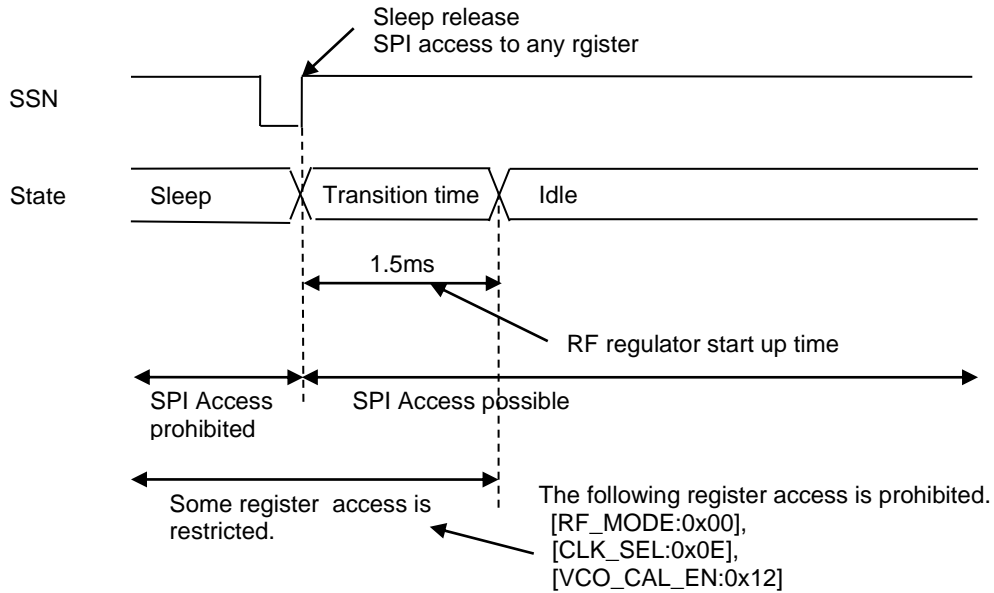

[Idle to ACT]

The following shows the operation timing from Idle state to ACT state.

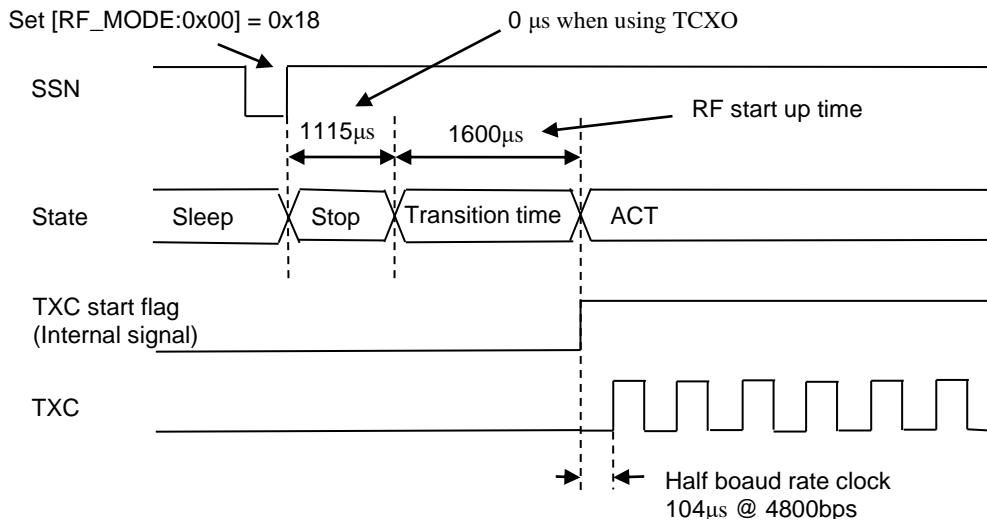

[ACT to Sleep]

The following shows the operation timing from ACT state to Sleep state.

Set [RF_MODE:0x00] = 0x40

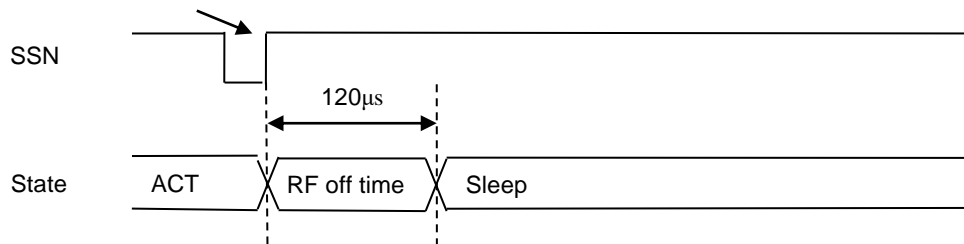

●VCO calibration

VCO calibration is the function to correct the VCO oscillation frequency due to the variation of chip components. Please refer “ML7386/ML7386B application manual”.

■Registers

●Register setting flow



The following shows the register setting flow which uses test pattern transmission as a reference.
For details of setting value to each register,
please refer to the “ML7386Family_Register_Tool20150106en.xls”.

No	Register Address	Setting value	Remark
1	0x0E	0x00	Select clock source (“Xtal”=0x00, “TCXO”=0x01)
2	0x01	0x00	Baud rate setting (2400bps)
3	0x02	0x08	Select test pattern (“PN9”=0x08, “CW”=0C, “1010”=0x09)
4	0x03	0x10	Channel frequency setting (426.250MHz)
5	0x04	0xC4	
6	0x05	0x4E	
7	0x06	0x06	
Execute VCO calibration Refer “ML7386/ML7386B Application manual”			
8	0x08	0x1A	Frequency deviation setting (2.1kHz)
9	0x09	0x31	
10	0x0A	0x44	
11	0x0B	0x50	
12	0x0C	0x54	
13	0x0D	0xFF	Frequency deviation transition time setting (2400bps)
Transmission power adjustment			
14	0x10	0x02	Select PA (“1mW”=00, “10mW”=0x01)
15	0x16	0x55	
16	0x17 *1	0x00	PA bias setting (“1mW”=02, “10mW”=0x07)
17	0x2A *1	0x00	Set ACT state
18	0x00	0x18	
Data transmitted after 2.715ms			
19	0x00	0x00	Stop transmission and move to Idle state.

*1: These registers are supported for ML7386B.

●Register map

The space shown as gray highlighted part are not implemented in LSI or reserved bits. The space shown as lined mesh part are required to fill fixed value. The address not exist in the memory map is not accessible.

-  : Implemented as functionable register (Read and Write)
-  : Impelemted as reserved bits
-  : Impelemted as required to fill fixed value

Address	Symbol	Function	Bit assignment								Default	
			7	6	5	4	3	2	1	0		
0x00	RF_MODE	RF state setting										0x00
0x01	BR	Baud Rate setting										0x00
0x02	TXD_SEL	Data configuration										0x00
0x03	PLL_N	PLL N parameter setting										0x10
0x04	PLL_FL	PLL Frequency setting (low byte)										0xC4
0x05	PLL_FM	PLL Frequency setting (middlebyte)										0x4E
0x06	PLL_FH	PLL Frequency setting (high4 bits)										0x06
0x07	PLL_FIT	PLL frequency adjustment										0x00
0x08	F_DEV0	Frequency deviation #0 setting										0x1A
0x09	F_DEV1	Frequency deviation #1 setting										0x32
0x0A	F_DEV2	Frequency deviation #2 setting										0x44
0x0B	F_DEV3	Frequency deviation #3 setting										0x52
0x0C	F_DEV4	Frequency deviation #4 setting										0x54
0x0D	T_PLL_TR	Frequency deviation transition time setting										0x86
0x0E	CLK_SEL	clock configuration										0x00
0x0F	SRST	Software reset setting	w	w	w	w	w	w	w	w	w	0x00
0x10	PA_ADJ	PA gain adjustment										0x77
0x11	VCO_CAL	VCO calibration value R/W control										0x20
0x12	VCO_CAL_EN	VCO calibration execution										0x00
0x13	PLL_CPI	PLL charge pump current control										0x0F
0x14	BR_FLEX_SET_L	Extended baud rate setting (low byte)										0x28
0x15	BT_FLEX_SET_H	Extended baud rate setting (high byte)										0x15
0x16	PA_BIAS	PA bias control										0x16
0x17	PA_SEL	PA selection										0x01
0x1A	F_DEV_RESO	Frequency deviation resolution setting										0x00
0x2A	PA_REG	PA regulator output setting										0x07

[Note] All register access is available when RSTN="H".
 The method to access each register described in "SPI Data format" section.

0x00[RF_MODE]

Function: RF state setting

Address: 0x00

Default value: 0x00

Bit	Symbol	Description	Default Value	R/W
7-0	rf_mode[7:0]	RF state setting x40: Sleep state (Regulator OFF, OSC OFF) x18: ACT state (TX ON) x10: Stop state (Regulator ON, OSC ON) x00: Idle state (Regulator ON, OSC OFF)	0000_0000	R/W

[Notes]

1. When write any other data shown in the list, ML7386 will move to Idle state
2. If executing VCO active calibration([VCO_CAL_EN:0x12]=0x01), 2.8ms wait is required after ACT state command execution.
3. During state transition time, SPI access is prohibited. Please refer to the “State Transition”.

0x01[BR]

Function: Baud rate setting

Address: 0x01

Default Value 0x00

Bit	Symbol	Description	Default Value	R/W
7-3	Reserved	Reserved	0000_0	R/W
2-0	baud_rate [2:0]	Baud rate setting 0b000: 2400 bps 0b001: 4800 bps 0b010: Reserved 0b011: 7200 bps 0b100: Reserved 0b101: Reserved 0b11*: Valid [BR_FLEX_L/H: 0x14/15] register setting	000	R/W

[Note]

1. When using 26MHz as a master clock, this register setting is valid. If using any other master clock frequency, baud_rate[2:0] should be set as 0b11* and data rate is set by [BR_FLEX_SET_/HL:0x14/15] registers.

0x02[TXD_SEL]

Function: Data configuration

Address: 0x02

Default Value 0x00

Bit	Symbol	Description	Default Value	R/W
7	txdinv	Data polarity 0: Positive (When TXD="1", plus frequency deviation) 1: Negative (When TXD="1", minus frequency deviation)	0	R
6	manchester_en	Coding control 0: NRZ coding 1: Manchester coding	0	R/W
5-4	Reserved	reserved	00	R/W
3	txtest_en	Output data selection 0: TXD input 1: Test pattern	0	R/W
2-0	txtest_sel[2:0]	Test pattern selection 0b000: PN9 (generated in LSI) 0b010: Continuous "0101" 0b010: All "0" 0b011: All "1" 0b1xx: Carrier Wave (xx are don't care)	000	R/W

[Coding]

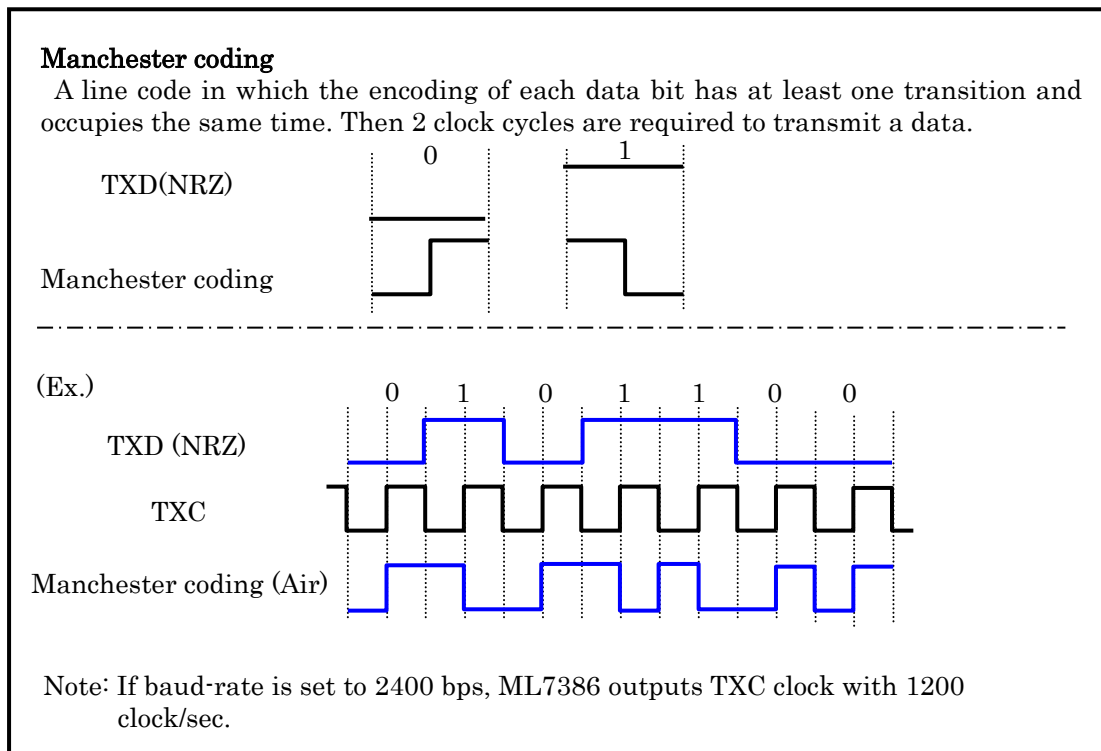

0x03[PLL_N]

Function: PLL “N” parameter setting

Address: 0x03

Default Value 0x10

426.2500MHz (Oscillation frequency: 26MHz)

Bit	Symbol	Description	Default Value	R/W
7-5	Reserved	Reserved	000	R/W
5-1	pll_set [24:20]	N parameter (5 bit) set	1_0000	R/W

[Detail description]

1. See section “Programming Channel frequency”

0x04[PLL_FL]

Function: PLL frequency setting (low byte)

Address: 0x04

Default Value 0xC4

426.2500MHz (Oscillation frequency: 26MHz)

Bit	Symbol	Description	Default Value	R/W
7-0	pll_set[7:0]	Frequency parameter for the the Channel (bit7 to bit0)	1100_0100	R/W

[Detail description]

1. See section “Programming Channel frequency”

0x05[PLL_FM]

Function: PLL frequency setting (middle byte)

Address: 0x05

Default Value 0x4e

426.2500MHz (Oscillationl frequency: 26MHz)

Bit	Symbol	Description	Default Value	R/W
7-0	pll_set[15:8]	Frequency parameter for the Channel (bit15 to bit8)	0100_1110	R/W

[Detail description]

1. See section “Programming Channel frequency”

0x06[PLL_FH]

Function: PLL Frequency setting (high byte)

Address: 0x06

Default Value :0x06

426.250MHz (Oscillation frequency: 26MHz)

Bit	Symbol	Description	Default Value	R/W
7-4	Reserved	Reserved	0000	R/W
3-0	pll_set[19:16]	Frequency parameter for the Channel (bit19 to bit16)	0110	R/W

[Detail description]

1. See section “Programming Channel frequency”

0x07[PLL_FIT]

Function: PLL frequency adjustment

Address: 0x07

Default Value 0x00

Bit	Symbol	Description	Default Value	R/W
7	pll_fit[7]	Polarity of PLL frequency adjustment offset 0: set as + 1: set as -	0	R/W
6-0	pll_fit[6:0]	Offset value (0 to 127) [Set value] * 25Hz	000_0000	R/W

0x08[F_DEV0]

Function: Frequency deviation #0 setting

Address: 0x08

Default Value 0x1A

Bit	Symbol	Description	Default Value	R/W
7-0	f_dev0[7:0]	Frequency deviation #0	0001_1010	R/W

[Detail description]

1. See section “Programming FSK modulation”

0x09[F_DEV1]

Function: Frequency deviation #1 setting

Address: 0x09

Default Value 0x32

Bit	Symbol	Description	Default Value	R/W
7-0	f_dev1[7:0]	Frequency deviation #1	0011_0010	R/W

[Detail description]

1. See section “Programming FSK modulation”

0x0A[F_DEV2]

Function: Frequency deviation #2 setting

Address: 0x0A

Default Value 0x44

Bit	Symbol	Description	Default Value	R/W
7-0	f_dev2[7:0]	Frequency deviation #2	0100_0100	R/W

[Detail description]

1. See section “Programming FSK modulation”

0x0B[F_DEV3]

Function: Frequency deviation #3 setting

Address: 0x0B

Default Value 0x52

Bit	Symbol	Description	Default Value	R/W
7-0	f_dev3[7:0]	Frequency deviation #3	0101_0010	R/W

[Detail description]

1. See section “Programming FSK modulation”

0x0C[F_DEV4]

Function: Frequency deviation #4 setting

Address: 0x0C

Default Value 0x54

Bit	Symbol	Description	Default Value	R/W
7-0	f_dev4[7:0]	Frequency deviation #4	0101_0100	R/W

[Detail description]

1. See section “Programming FSK modulation”

0x0D[T_PLL_TR]

Function: Frequency deviation transition time setting

Address: 0x0D

Default Value 0x86

Bit	Symbol	Description	Default Value	R/W
7-0	tim_plltr[7:0]	Frequency deviation transition time [Set value] * 0.154 us Default(0x86) = 20.6 us	1000_0110	R/W

[Detail description]

1. See section “Programming Frequency deviation”
2. It is necessary to adjust parametr depending on the data rate which is defined by [BR] register (x01).
See table below.

Data rate [bps]	[BR:0x01] register baud_rate[2:0]	tim_plltr[7:0]
2400	0b000	0xFF
4800	0b001	0x87
7200	0b011	0x5A

0x0E[CLK_SEL]

Function: Clock configuration

Address: 0x0E

Default Value 0x00

Bit	Symbol	Description	Default Value	R/W
7-1	Reserved	Reserved	0000_00	R/W
1	Fixed value	Fixed with 0b0	0	R/W
0	srck_sel	Input clock type select 0: OSC 1: TCXO	0	R/W

0x0F[SRST]

Function: Software reset control

Address: 0x0F

Default Value 0x00

Bit	Symbol	Description	Default Value	R/W
7-0	srstn[7:0]	software reset 0x46 : Reset RF (digital block) 0xA7: Reset whole block (register initialization) *1	0000_0000	W

[Note]

*1 : It seems that [VCO CAL:0x11] register is not initialized by “0xA7” software reset. Since the register reload the value which located in RF(digital block) after reset.

0x10[PA_ADJ]

Function: Output power adjustment

Address: 0x10

Default Value 0x77

Bit	Symbol	Description	Default Value	R/W
7-4	pa_adj[3:0]	Adjustment value for PA output. (10mW mode) 0b1111: Max output 0b000 : Minimum output	0111	R/W
3-0	pa_adj0[3:0]	Adjustment value for PA output. (1mW mode) 0b1111: Max output 0b000 : Minimum output	0111	R/W

[Detail description]

1. For more details, please refer to the “10mW TX power adjustment” or “1mW TX power adjustment”

0x11[VCO_CAL]

Function: VCO calibration value read or write control

Address: 0x11

Default Value 0x20

Bit	Symbol	Description	Default Value	R/W
7	b_vcoovr_cal	Overwrite enable 0: Read mode 1: Overwrite mode	0	R/W
6	Reserved	Reserved	0	R/W
5-0	b_vco_cal[5:0]	VCO calibration data If bit7=0, Current VCO calibration result If bit7=1, Overwrite value 0b00_0000: Minimum value 0b11_1111: Maximum value	10_0000	R/W

0x12[VCO_CAL_EN]

Function: VCO calibration enable control

Address: 0x12

Default Value 0x00

Bit	Symbol	Description	Default Value	R/W
7-2	Reserved	Reserved	0000_00	R/W
1	vco_seq_cal_en	When set to "1", VCO Idle calibration will be started. After completion of calibration, this bit will be cleared to 0b0.	0	R/W
0	vco_ove_cal_en	When set to "1", VCO active calibration will be started. After completion of calibration, this bit will be cleared to 0b0.	0	R/W

[Detail description]

1. For mode details, please refer to the "VCO calibration".

0x13[PLL_CPI]

Function: PLL charge pump current control

Address: 0x13

Default Value 0x0F

Bit	Symbol	Description	Default Value	R/W
7-4	Reserved	Reserved	0000	R/W
3	Fixed value	Fixed with 0b1.	1	R/W
0	cp_cal[2:0]	Charge pump current selection (Adjusting PLL loop band width) 0b000: 10μA 0b111: 150μA (Change 20μA per 1 LSB)	111	R/W

0x14[BR_FLEX_SET_L]

Function: Extended baud-rate setting (low byte)

Address: 0x14

Default Value 0x28

Bit	Symbol	Description	Default Value	R/W
7-0	br_flex_set[7:0]	Extended baud-rate setting (low byte) Note: Combined together with [BR_FLEX_SET_H:0x15] register. Set value = (Master clock / wanted baud-rate / 2) - 1	0010_1000	R/W

[Notes]

1. If [BR:0x01] is set to 0x06 or 0x07, extended baud-rate setting becomes valid.
2. If using extended baud-rate operation, evaluation and confirmation should be required under user specific condition.

0x15[BR_FLEX_SET_H]

Function: Extended baud-rate setting (high byte)

Address: 0x15

Default Value 0x15

Bit	Symbol	Description	Default Value	R/W
7-0	br_flex_set[15:8]	Extended baud-rate setting (high byte) For details please refer to [BR_FLEX_SET_L] register	0001_0101	R/W

[Extended baud-rate setting]

When want to use 32.768kbps with 26MHz master clock.

$$(26.000,000 / 32768 / 2) = 1 = 395.7 = 0x018b$$

Then;

$$[BR_FLEX_SET_L:0x14] = 0x8b$$

$$[BR_FLEX_SET_H:0x15] = 0x01$$

0x16[PA_BIAS]

Function: Bias adjustment for PA

Address: 0x16

Default Value 0x55

Bit	Symbol	Description	Default Value	R/W
7	Fixed value	Fixed with 0b0	0	R/W
6	local_bias	Local buffer set for 10mW mode 0b1: Max bias (Max output power) 0b0: Minimum bias	1	R/W
5-4	pa_bias [1:0]	PA bias set for 10mW mode 0b11: Max bias (Max output power) 0b00: Minimum bias	01	R/W
3	Fixed value	Fixed with 0b0	0	R/W
2	local_bias0	Local buffer set for 1mW mode 0b1: Max bias (Max output power) 0b0: Minimum bias	1	R/W
1-0	pa_bias0[1:0]	PA bias set for 1mW mode 0b11: Max bias (Max output power) 0b00: Minimum bias	01	R/W

[Detail description]

1. This register control the bias level for PA and used for coarse adjustment of output power.

0x17[PA_SEL]

Function: PA selection

Address: 0x17

Default Value 0x01

Bit	Symbol	Description	Default Value	R/W
7-2	Reserved	Reserved	0000_00	R/W
1	pa_off	PA state 0: Normal operation 1: OFF state	0	R/W
0	pa_sel	PA selection 0: 1mW mode 1: 10mW mode	1	R/W

0x1A[F_DEV_RESO]

Function: Frequency deviation resolution setting

Address: 0x1A

Default Value 0x00

Bit	Symbol	Description	Default Value	R/W
7-4	Reserved	Reserved	0000	R/W
3-0	dev_reso[3:0]	Frequency deviation resolution (setting range: 0 to 4) y=setting value (0 to 4) Resolution = 2 ^y * (Fref/2 ²⁰) [Hz] Fref: Master clock frequency	0000	R/W

[Note] If using this register, evaluation and confirmation should be required under user specific condition.

The following shos the relation between resolution and setting value (Fref=26MHz)

dev_reso[3:0]	Resolution [Hz]	Max frequency deviation [kHz]
0b0000	25	6.3
0b0001	50	12.7
0b0010	99	25.3
0b0011	198	50.6
0b0100	396	101.2

0x2A[PA_REG]

Function: PA regulator output setting

Address: 0x2A

Default Value 0x07

Bit	Symbol	Description	Default Value	R/W
7-3	Reserved	Reserved	0000_0	R/W
2-0	pa_reg[2:0]	PA regulator output setting 0b010: 1mW mode 0b111: 10mW mode Other setting: reserved	111	R/W

[Note] Appropriate value should be set according to the RF design.

■RF Adjustment**●Tx Power Adjustment**

The ML7386B has two Power Amplifiers(PA) for 10mW mode and 1mW mode. Appropriate PA should be selected in the design. This section shows the power adjusting methodology for each power mode.

In each power mode, optimum matching circuit should be required. In the 10mW mode design, if select 1mW mode PA, RF performances are not guaranteed. Same as in 1mW mode design.

●10mW Tx Power Adjustment

It is possible to adjust the Tx power by [PA_ADJ:0x10] and [PA_BIAS:0x16] registers. The following flow shows the example to adjusting Tx power to 10mW.

Adjusting power range should be set to more than +/- 5% to the desired level.

(In the following flow, the upper limit set to 11mW and the lower limit set to 9mW, ie +/- 10%.)

- pa_sel: located at bit 0 of [PA_SEL:0x2A] reister
 - pa_adj : located at bit 7-4 of [PA_ADJ:0x10] register
 - local_bias: located at the bit 6 of [PA_BIAS:0x16] register
 - pa_bias: located at bit 5-4 of [PA_BIAS:0x16] register
 - pa_reg: located at bit 2-0 of [PA_REG:0x2A] register
- All number inforation is described in decimal.

[10mW search flow]

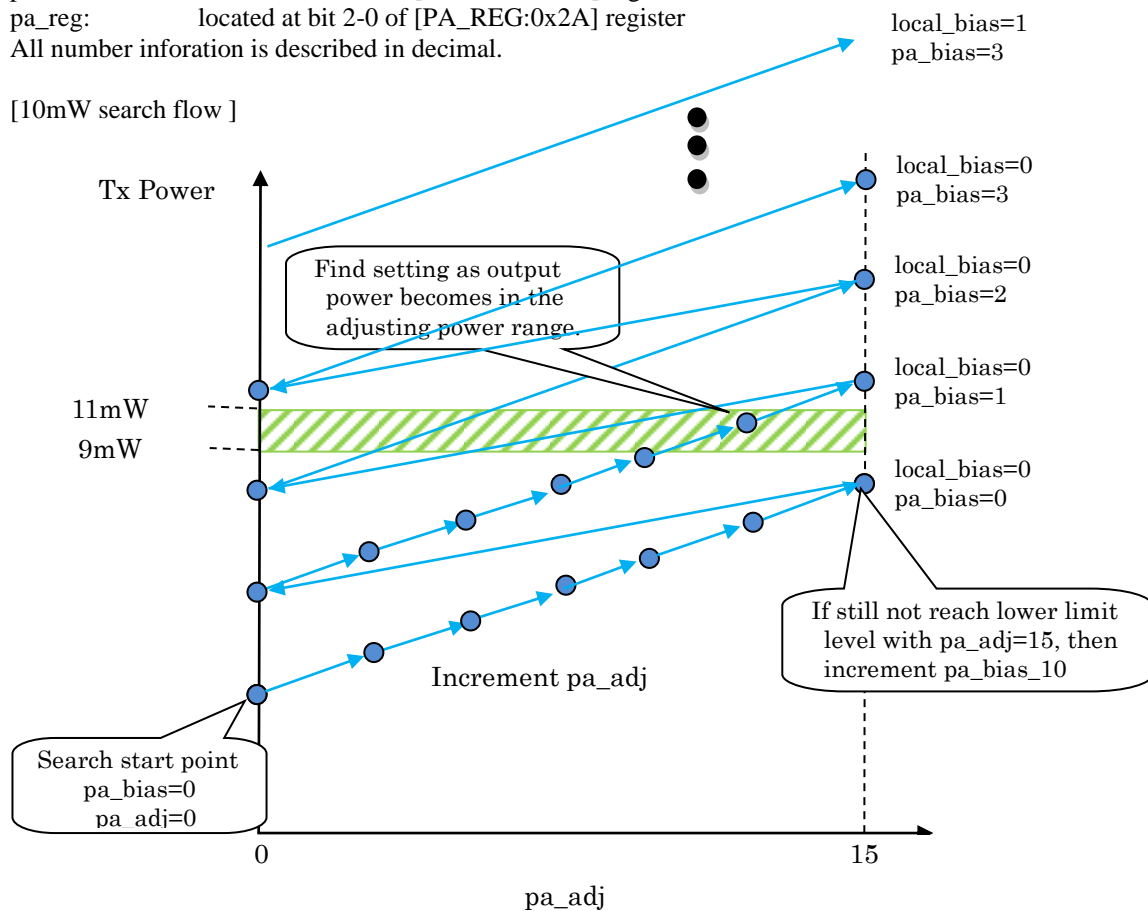

[Note] If set local_bias=1, higher power is achivable than local_bias=0. Overrup power zone will exist.

[10mW power adjustment flow]
 All number information is described in decimal.

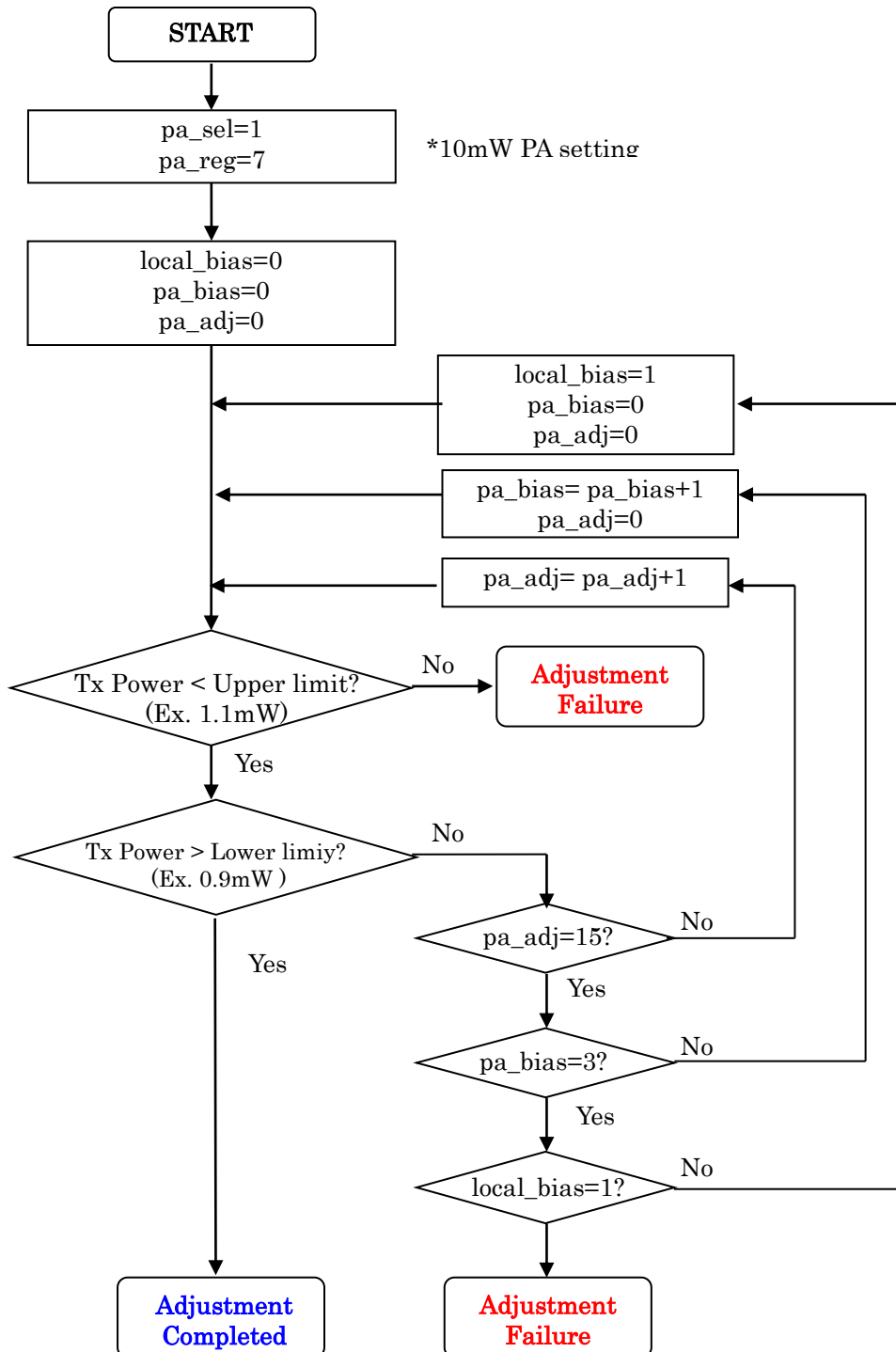

●1mW Tx Power Adjustment

It is possible to adjust the Tx power by [PA_ADJ:0x10] and [PA_BIAS:0x16] registers. The following flow shows the example to adjusting Tx power to 10mW.

Adjusting power range should be set to more than +/- 5% to the desired level.

(In the following flow, the upper limit set to 1.1mW and the lower limit set to 0.9mW, ie +/- 10%.)

- pa_sel: located at bit 0 of [PA_SEL:0x2A] register
 - pa_adj0 : located at bit 3-0 of [PA_ADJ:0x10] register
 - local_bias0: located at the bit 2 of [PA_BIAS:0x16] register
 - pa_bias0: located at bit 1-0 of [PA_BIAS:0x16] register
 - pa_reg: located at bit 2-0 of [PA_REG:0x2A] register
- All number information is described in decimal.

[1mW search flow]

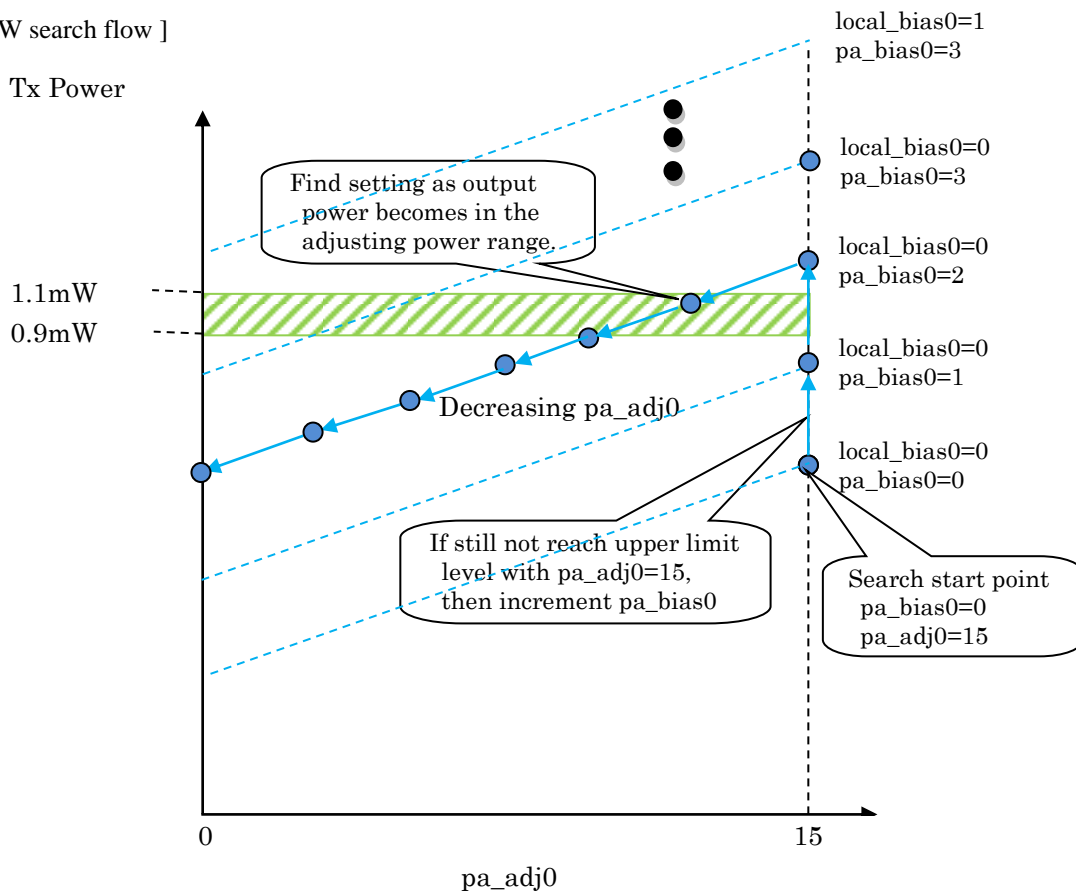

[Note] If set local_bias0=1, higher power is achivable than local_bias0=0. Overrup power zone will exist.

[1mW power adjustment flow]
 All number information is described in decimal.

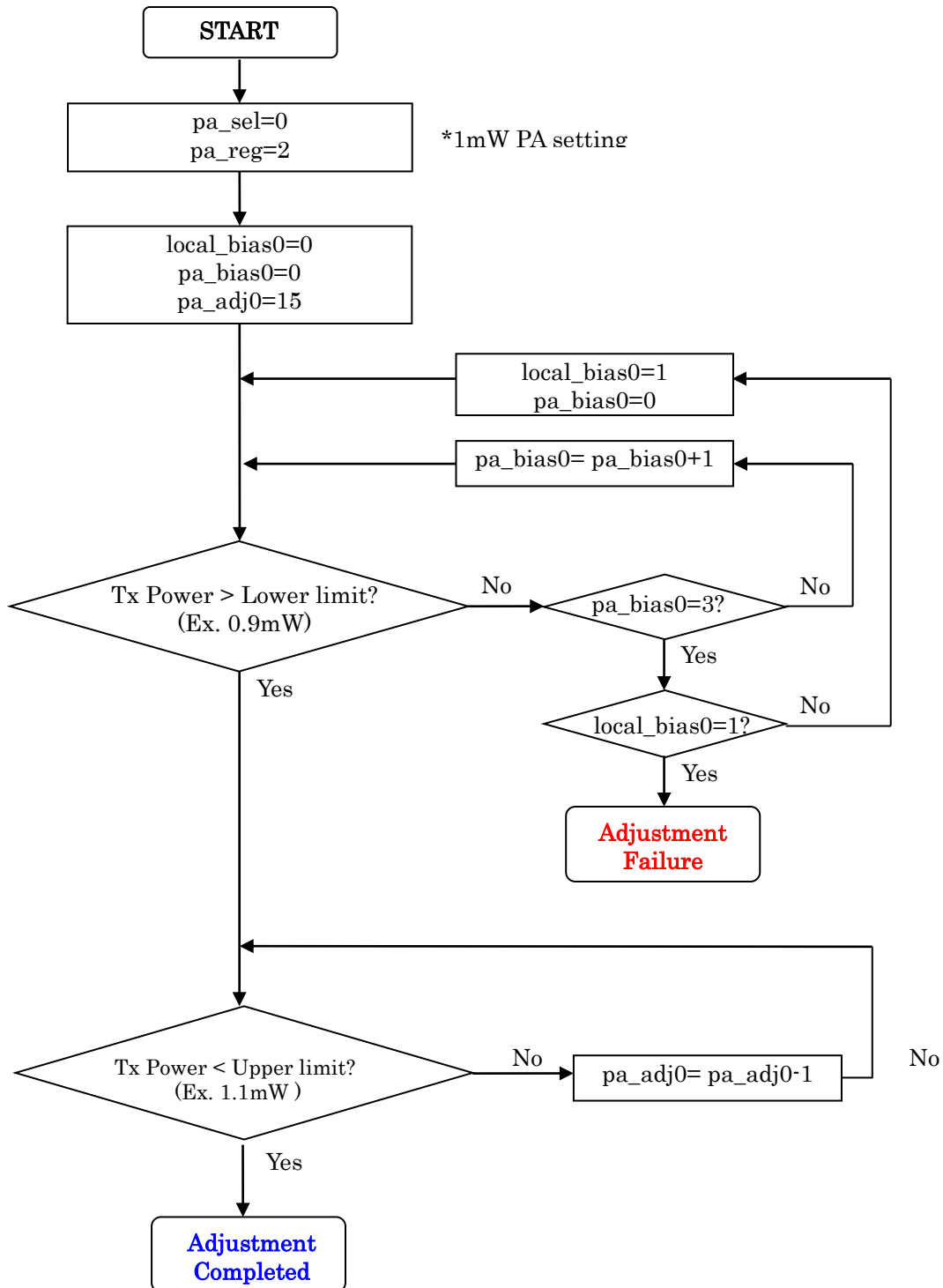

●Programming Channel Frequency

It is possible to configure channel frequency by registers of [PLL_N:0x03], [PLL_FL:0x04], [PLL_FM:0x05] and [PLL_FH:0x06] registers.

The relation between setting frequency and each parameter are shown in the following formula.

$$f = f_{\text{REF}} * (N + F/2^{20})$$

f : PLL oscillation frequency
 freal : Desired frequency
 ferr : frequency error (freal – f)
 f_{REF} : PLL reference frequency (master clock: 26MHz)
 N : N parameter (Integer part)
 F : F parameter (Fractional part)

Each frequency register will have following values.

$$N = \text{int}[f / f_{\text{REF}}]$$

$$F = \text{int}[(f / f_{\text{REF}} - N) * 2^{20}] \dots \text{Internal block uses 20 bits width}$$

Therefore frequency error will be $\text{ferr} = \text{freal} - \{f_{\text{REF}} * (N + F/2^{20})\}$

Ex) If f=426.2500MHz, each parameter will be as follows when f_{REF} = 26MHz

$$N = \text{int}[426.2500\text{M} / 26\text{M}] = 16$$

$$F = \text{int}[\{426.2500\text{M} / 26\text{M} - 16\} * 2^{20}] = 413380 \text{ (0x64EC4)}$$

Here

$$[\text{PLL_N:0x03}] = 0x10$$

$$[\text{PLL_FL:0x04}] = 0xC4$$

$$[\text{PLL_FM:0x05}] = 0x4E$$

$$[\text{PLL_NA:0x06}] = 0x06$$

In this case frequency error will be $\text{ferr} = 426.2500\text{M} - \{26\text{M} * (16 + 413380/2^{20})\} = +22.9\text{Hz}$

Setting resolution depends on master clock. If 26MHz, the resolution is 25Hz.

Following shows the setting table for 426MHz channels of Japan band as reference.

[RCR STD-30]

CH No.	Frequency [MHz]	PLL_NA (0x03)	PLL_FL (0x04)	PLL_FM (0x05)	PLL_FH (0x06)	Ferr (Hz)
1	426.2500	10	C4	4E	06	22.9
2	426.2625	10	BD	50	06	1.1
3	426.2750	10	B5	52	06	4.2
4	426.2875	10	AD	54	06	7.2
5	426.3000	10	A5	56	06	10.3
6	426.3125	10	9D	58	06	13.4
7	426.3250	10	95	5A	06	16.4
8	426.3375	10	8D	5C	06	19.5
9	426.3500	10	85	5E	06	22.5
10	426.3625	10	7E	60	06	0.8
11	426.3750	10	76	62	06	3.8
12	426.3875	10	6E	64	06	6.9
13	426.4000	10	66	66	06	9.9
14	426.4125	10	5E	68	06	13.0
15	426.4250	10	56	6A	06	16.0
16	426.4375	10	4E	6C	06	19.1
17	426.4500	10	46	6E	06	22.1
18	426.4625	10	3F	70	06	0.4
19	426.4750	10	37	72	06	3.4
20	426.4875	10	2F	74	06	6.5
21	426.5000	10	27	76	06	9.5
22	426.5125	10	1F	78	06	12.6
23	426.5250	10	17	7A	06	15.6
24	426.5375	10	0F	7C	06	18.7
25	426.5500	10	07	7E	06	21.7
26	426.5625	10	00	80	06	0.0
27	426.5750	10	F8	81	06	3.1
28	426.5875	10	F0	83	06	6.1
29	426.6000	10	E8	85	06	9.2
30	426.6125	10	E0	87	06	12.2
31	426.6250	10	D8	89	06	15.3
32	426.6375	10	D0	8B	06	18.3
33	426.6500	10	C8	8D	06	21.4
34	426.6625	10	C0	8F	06	24.4
35	426.6750	10	B9	91	06	2.7
36	426.6875	10	B1	93	06	5.7

[RCR STD-30] (continue)

CH No.	Frequency [MHz]	PLL_NA (0x03)	PLL_FL (0x04)	PLL_FM (0x05)	PLL_FH (0x06)	Ferr (Hz)
37	426.7000	10	A9	95	06	8.8
38	426.7125	10	A1	97	06	11.8
39	426.7250	10	99	99	06	14.9
40	426.7375	10	91	9B	06	17.9
41	426.7500	10	89	9D	06	21.0
42	426.7625	10	81	9F	06	24.0
43	426.7750	10	7A	A1	06	2.3
44	426.7875	10	72	A3	06	5.3
45	426.8000	10	6A	A5	06	8.4
46	426.8125	10	62	A7	06	11.4
47	426.8250	10	5A	A9	06	14.5
48	426.8375	10	52	AB	06	17.5

[ARIB STD-T67]

CH No.	Frequency [MHz]	PLL_NA (0x03)	PLL_FL (0x04)	PLL_FM (0x05)	PLL_FH (0x06)	Ferr (Hz)
1	426.0250	10	52	2B	06	17.55
2	426.0375	10	4A	2D	06	20.60
3	426.0500	10	42	2F	06	23.65
4	426.0625	10	3B	31	06	1.91
5	426.0750	10	33	33	06	4.96
6	426.0875	10	2B	35	06	8.01
7	426.1000	10	23	37	06	11.06
8	426.1125	10	1B	39	06	14.11
9	426.1250	10	13	3B	06	17.17
10	426.1375	10	0B	3D	06	22.22

The following table shows the relation between master clock and frequency setting range

Master clock [MHz]	PLL frequency setting range		Frequency Resolution [Hz]
	Minimum [MHz]	Maximum [MHz]	
18	200	486	17
19	211	513	18
20	222	540	19
21	233	567	20
22	244	594	21
23	255	621	22
24	266	648	23
25	278	675	24
26	289	702	25
27	300	729	26
28	311	756	27
29	322	783	28
30	333	810	29
31	344	837	30
32	355	864	31
33	366	891	31
34	377	918	32
35	389	945	33
36	400	972	34

●Programming FSK modulation

ML7386/ML7386B outputs filtered FSK modulation, the shaping figure is defined by following registers [F_DEV0:0x08] to [F_DEV4:0x0C] and [T_PLL_TR: 0x0D] registers.

Keeping better performance of OBW and spurious emission, each fdev parameter should be set as below table depends on the wanted frequency deviation. Tansision time parameter should be set depends on the data rate.

If using except for 26MHz master clock, the setting parameters can be calculated by the "ML7386Family_Register_Tool20150106en.xls".

And evaluation and confirmation should be required under user specific condition.

[Frequency deviation setting list]

[Master Clock = 26MHz]

Fdev (KHz)	F_DEV0 (0x08)	F_DEV1 (0x09)	F_DEV2 (0x0A)	F_DEV3 (0x0B)	F_DEV4 (0x0C)
0.6	07	0E	13	16	18
0.7	08	10	16	1A	1C
0.8	0A	13	1A	1E	20
0.9	0B	15	1D	22	24
1.0	0C	17	20	26	28
1.1	0D	1A	23	2A	2C
1.2	0F	1C	27	2D	30
1.3	10	1E	2A	31	34
1.4	11	21	2D	35	38
1.5	12	23	31	39	3C
1.6	14	26	34	3D	40
1.7	15	28	37	41	44
1.8	16	2A	3A	44	48
1.9	17	2D	3E	48	4C
2.0	19	2F	41	4C	50
2.1 (default)	1A	31	44	50	54
2.2	1B	34	47	54	58
2.3	1C	36	4B	58	5C
2.4	1E	39	4E	5B	60
2.5	1F	3B	51	5F	64
2.6	20	3D	54	63	68
2.7	21	40	58	67	6C
2.8	23	42	5B	6B	70
2.9	24	45	5E	6F	74
3.0	25	47	62	72	78

[Master Clock = 26MHz] (continue)

Fdev (KHz)	F_DEV0 (0x08)	F_DEV1 (0x09)	F_DEV2 (0x0A)	F_DEV3 (0x0B)	F_DEV4 (0x0C)
3.1	26	49	65	76	7D
3.2	28	4C	68	7A	81
3.3	29	4E	6B	7E	85
3.4	2A	50	6F	82	89
3.5	2B	53	72	86	8D
3.6	2D	55	75	89	91
3.7	2E	58	78	8D	95
3.8	2F	5A	7C	91	99
3.9	30	5C	7F	95	9D
4.0	32	5F	82	99	A1
4.1	33	61	85	9D	A5
4.2	34	63	89	A0	A9

[Frequency deviation transition time setting list]

[Master Clock = 26MHz]

Data rate [bps]	[T_PLL_TR: 0x0D] Tim_plltr[7:0]
2400	0xFF
4800	0x87
7200	0x5A

●Fractional Spurious

Fractional N spurious appears depends on the carrier frequency by following equations.

1. fractional[Carrier frequency / master clock] * master clock
2. (1- fractional[Carrier frequency /master clock]) * master clock

If a fractional spurious appears within +/- 200 kHz to the channel frequency, the fractional spurious emission could not be decreased. It is strongly recommended that the channel frequency should not be used.

So it means the range +/- 200 kHz to (26MHz * n) is not usable. (n=1,2,3.)

ML7386/ML7386B supports the operation frequency range from 200MHz to 972MHz. For this range following frequency is unable operation frequency by the fractional spurious.

[Master Clock = 26MHz]

n	Spurious frequency [MHz]	Spurious lower limit [MHz]	Spurious upper limit [MHz]
n=8	208	207.8	208.2
n=9	234	233.8	234.2
n=10	260	259.8	260.2
n=11	286	285.8	286.2
n=12	312	311.8	312.2
n=13	338	337.8	338.2
n=14	364	363.8	364.2
n=15	390	389.8	390.2
n=16	416	415.8	416.2
n=17	442	441.8	442.2
n=18	468	467.8	468.2
n=19	494	493.8	494.2
n=20	520	519.8	520.2
n=21	546	545.8	546.2
n=22	572	571.8	572.2
n=23	598	597.8	598.2
n=24	624	623.8	624.2
n=25	650	649.8	650.2
n=26	676	675.8	676.2
n=27	702	701.8	702.2
n=28	728	727.8	728.2
n=29	754	753.8	754.2
n=30	780	779.8	780.2
n=31	806	805.8	806.2
n=32	832	831.8	832.2
n=33	858	857.8	858.2
n=34	882	881.8	882.2
n=35	908	907.8	908.2
n=36	934	933.8	934.2
n=37	960	959.8	960.2

■Package diagram

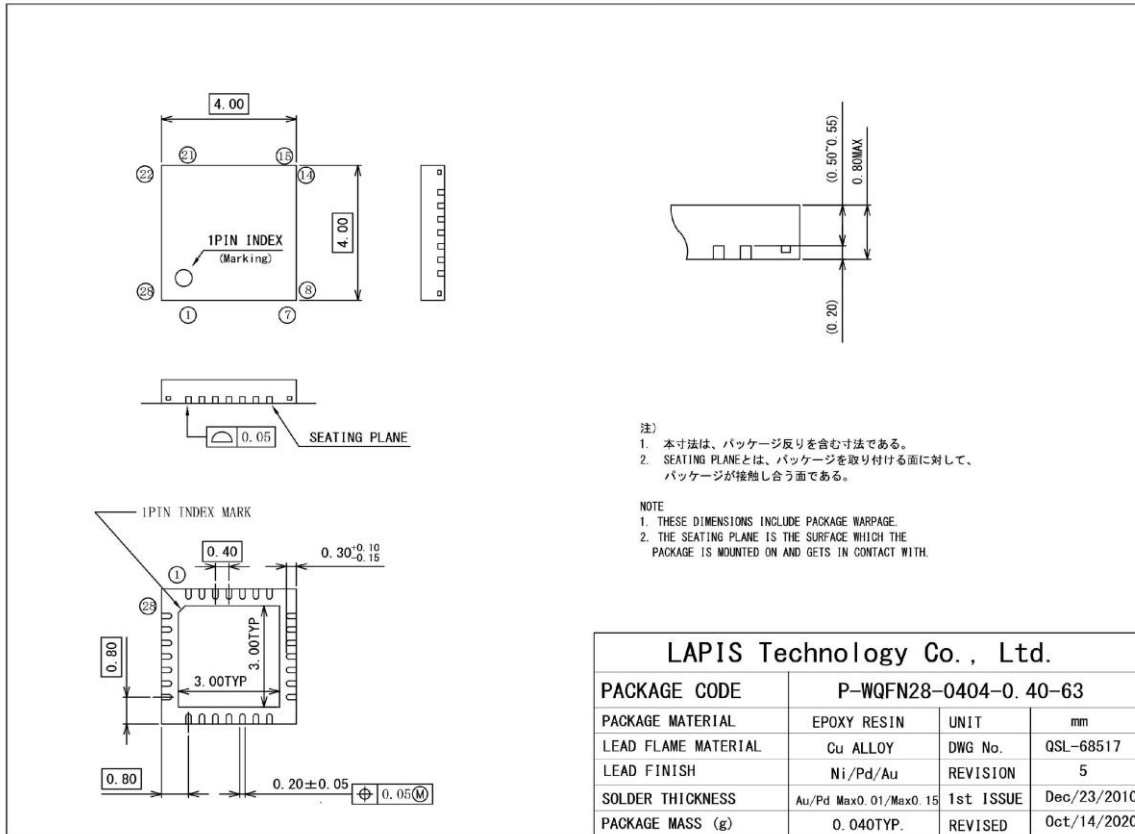

Remarks for surface mount type package

Surface mount type package is very sensitive affected by heating from reflow process, humidity during storing. Therefore, in case of reflow mouting process, please contact sales representative about product name, package name, number of pin, package code and required reflow process condition (reflow method, temperature, number of reflow process), storage condition.

■Reference Footprint Pattern (Recommendation)

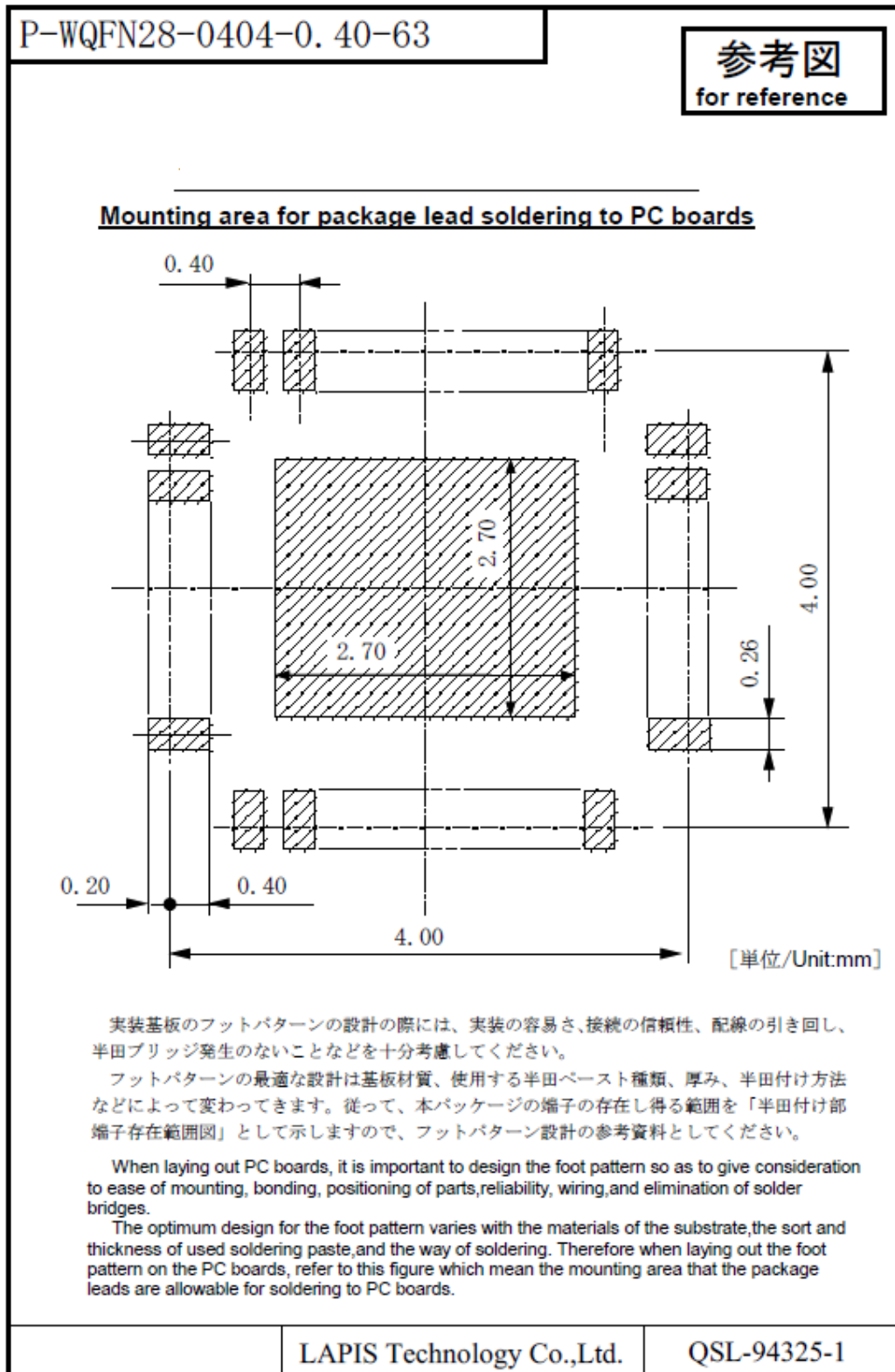

■Revision History

Document No.	Date	Page		Description
		Previous Edition	Current Edition	
FEDL7386-01	Dec. 27, 2011	–	–	Initial release (ML7386)
FEDL7386B-01	Dec. 3, 2012	–	–	Initial release (ML7386B including ML7386)
FEDL7386B-02	Jan. 7, 2013	–	15	Added Timing characteristics
FEDL7386B-03	Feb. 18, 2013	–	1	Modified TX Frequency range
FEDL7386B-04	Jun. 11, 2013	–	34	Added PLL_CPI register setting
FEDL7386B-05	Sep. 27, 2013	–	24	Added register setting flow
FEDL7386B-06	Mar. 13, 2014	13	13	Modified TX Frequency range
FEDL7386B-07	Apr. 16, 2014	27	27	Modified a polarity of txdiv
FEDL7386B-08	Mar. 06, 2020	23	23	Modified the sentence of VCO Calibration
		24	24	Modified the Register setting flow
		35	35	Modified the register explanation. 0x17[PA_SEL]
		24,46	24,46	Updated the register setting tool. ML7386Family_Register_Tool20150106en.xls
FEDL7386B-09	Nov. 1, 2023	all	all	Change of company name
		18	18	Added note in power on
		1	1	Add application
		1	1	Add Product Name
		53	53	The description of [Note] has been updated.
FEDL7386B-10	Jan. 10, 2024	53	53	The description of [Note] has been updated.

Notes

- 1) When using LAPIS Technology Products, refer to the latest product information and ensure that usage conditions (absolute maximum ratings^{*1}, recommended operating conditions, etc.) are within the ranges specified. LAPIS Technology disclaims any and all liability for any malfunctions, failure or accident arising out of or in connection with the use of LAPIS Technology Products outside of such usage conditions specified ranges, or without observing precautions. Even if it is used within such usage conditions specified ranges, semiconductors can break down and malfunction due to various factors. Therefore, in order to prevent personal injury, fire or the other damage from break down or malfunction of LAPIS Technology Products, please take safety at your own risk measures such as complying with the derating characteristics, implementing redundant and fire prevention designs, and utilizing backups and fail-safe procedures.
*1: Absolute maximum ratings: a limit value that must not be exceeded even momentarily.
- 2) The Products specified in this document are not designed to be radiation tolerant.
- 3) Descriptions of circuits, software and other related information in this document are provided only to illustrate the standard operation of semiconductor products and application examples. You are fully responsible for the incorporation or any other use of the circuits, software, and information in the design of your product or system. And the peripheral conditions must be taken into account when designing circuits for mass production. LAPIS Technology disclaims any and all liability for any losses and damages incurred by you or third parties arising from the use of these circuits, software, and other related information.
- 4) No license, expressly or implied, is granted hereby under any intellectual property rights or other rights of LAPIS Technology or any third party with respect to LAPIS Technology Products or the information contained in this document (including but not limited to, the Product data, drawings, charts, programs, algorithms, and application examples, etc.). Therefore, LAPIS Technology shall have no responsibility whatsoever for any dispute, concerning such rights owned by third parties, arising out of the use of such technical information.
- 5) LAPIS Technology intends our Products to be used in a way indicated in this document. Please be sure to contact a ROHM sales office if you consider the use of our Products in different way from original use indicated in this document. For use of our Products in medical systems, please be sure to contact a LAPIS Technology representative and must obtain written agreement. Do not use our Products in applications which may directly cause injuries to human life, and which require extremely high reliability, such as aerospace equipment, nuclear power control systems, and submarine repeaters, etc. LAPIS Technology disclaims any and all liability for any losses and damages incurred by you or third parties arising by using the Product for purposes not intended by us without our prior written consent.
- 6) All information contained in this document is subject to change for the purpose of improvement, etc. without any prior notice. Before purchasing or using LAPIS Technology Products, please confirm the latest information with a ROHM sales office. LAPIS Technology has used reasonable care to ensure the accuracy of the information contained in this document, however, LAPIS Technology shall have no responsibility for any damages, expenses or losses arising from inaccuracy or errors of such information.
- 7) Please use the Products in accordance with any applicable environmental laws and regulations, such as the RoHS Directive. LAPIS Technology shall have no responsibility for any damages or losses resulting non-compliance with any applicable laws or regulations.
- 8) When providing our Products and technologies contained in this document to other countries, you must abide by the procedures and provisions stipulated in all applicable export laws and regulations, including without limitation the US Export Administration Regulations and the Foreign Exchange and Foreign Trade Act.
- 9) Please contact a ROHM sales office if you have any questions regarding the information contained in this document or LAPIS Technology's Products.
- 10) This document, in part or in whole, may not be reprinted or reproduced without prior consent of LAPIS Technology.

(Note) "LAPIS Technology" as used in this document means LAPIS Technology Co., Ltd.

Copyright 2011 – 2024 LAPIS Technology Co., Ltd.

LAPIS Technology Co.,Ltd.

2-4-8 Shinyokohama, Kouhoku-ku, Yokohama 222-8575, Japan

<https://www.lapis-tech.com/en/>