



Dear customer

ROHM Co., Ltd. ("ROHM"), on the 1st day of April, 2024,
has absorbed into merger with 100%-owned subsidiary of LAPIS Technology Co., Ltd.

Therefore, all references to "LAPIS Technology Co., Ltd.", "LAPIS Technology"
and/or "LAPIS" in this document shall be replaced with "ROHM Co., Ltd."

Furthermore, there are no changes to the documents relating to our products other than
the company name, the company trademark, logo, etc.

Thank you for your understanding.

ROHM Co., Ltd.
April 1, 2024

Dear customer

LAPIS Semiconductor Co., Ltd. ("LAPIS Semiconductor"), on the 1st day of October, 2020, implemented the incorporation-type company split (shinsetsu-bunkatsu) in which LAPIS established a new company, LAPIS Technology Co., Ltd. ("LAPIS Technology") and LAPIS Technology succeeded LAPIS Semiconductor's LSI business.

Therefore, all references to "LAPIS Semiconductor Co., Ltd.", "LAPIS Semiconductor" and/or "LAPIS" in this document shall be replaced with "LAPIS Technology Co., Ltd."

Furthermore, there are no changes to the documents relating to our products other than the company name, the company trademark, logo, etc.

Thank you for your understanding.

LAPIS Technology Co., Ltd.
October 1, 2020

MK71511/MK71511A

Bluetooth® low energy wireless module

■ Overview

MK71511/MK71511A is a wireless module which is integrating Bluetooth® low energy LSI nRF52811, 32MHz/ 32.768kHz crystal oscillator, 2.4GHz PCB pattern antenna and passive components.

MK71511/MK71511A is suitable for applications such as Healthcare, fitness device, security device, IoT devices (industrial / consumer).

■ Features

- Bluetooth® Ver5.2 low energy module
- Radio certification
 - MIC JAPAN (certification no: 006-000797 [MK71511] / 006-000799 [MK71511A])
 - FCC(FCC ID:2ACIJ71511)
 - ISED(IC:20971-71511)
 - CE(RED) EN300 328 V2.1.1
- Bluetooth® Qualification (RF-PHY Component Qualification, QDID:146733)
- Bluetooth® low energy LSI Nordic nRF52811
 - 2.4GHz Transceiver
 - -97dBm sensitivity in 1Mbps Bluetooth® low energy mode
 - -104dBm sensitivity in 125kbps Bluetooth® low energy mode(long range)
 - Supported data rate:2Mbps,1Mbps,500kbps,125kbps Bluetooth® low energy mode
 - -20 to +4dBm TX power,configurable in 4dB steps
 - RSSI(1dB resolution)
 - 64MHz Arm® Cortex®-M4 processor
 - Flash192kB、RAM24kB
 - 128bit AES ECB/CCM/AAR
 - Digital Interface:SPI/I2C/UART/PDM/QDEC
 - ADC 12-bit 200 ksps
 - Comparators General purpose, low-power
 - Temperature sensor
 - Timers/Counters 32-bit, RTC
 - Pulse width modulator(PWM)
- Integrated 32MHz /32.768kHz crystal oscillator (※)
- Integrated bypass capacitor and external component of switching regulator
- General Purpose Input/Output (Maximum 30ports[MK71511]/Maximum 32ports[MK71511A])
- Single power supply 1.7V to 3.6V (Typ.3.0V)
- Operating Temperature -40 deg.C to 85 deg.C
- Current Consumptions
 - Active RX (1Mbps) 4.6 mA
 - Active TX (0dBm) 4.6 mA
- PKG M-FLGA54-9.7X13.4-0.80-9Y
- Dimension 9.7 mm(W)×13.4 mm(L)×2.0 mm(H)(TYP)
- Pb Free, RoHS compliant

(※) MK71511A does not built-in a 32.768kHz crystal oscillator.



• Lineup

Certified product name	Official product name	Flash code	32.768kHz crystal oscillator	Remarks
MK71511	MK71511-NNNYEZ05B	Blank	Equipped	T&Rpacking (500 pieces)
MK71511	MK71511A-NNNYEZ05B	Blank	Not equipped	T&Rpacking (500 pieces)

■ Block Diagram

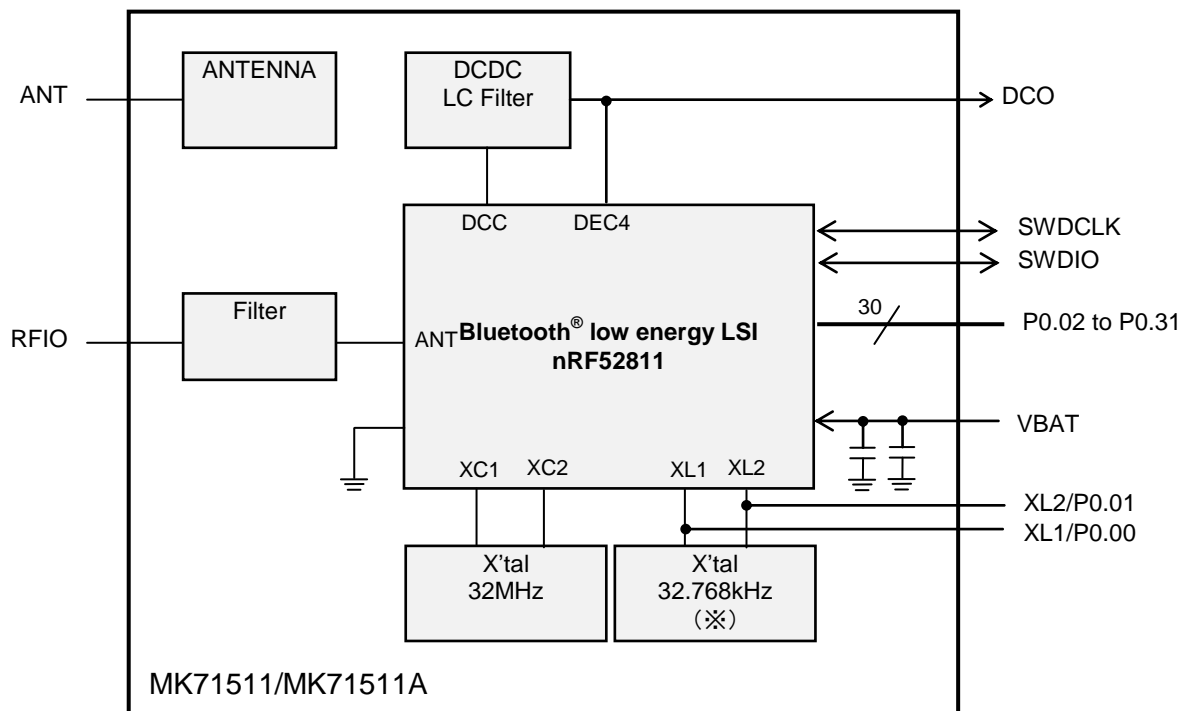

(※) MK71511A does not built-in a 32.768kHz crystal oscillator.

■ Pin Layout

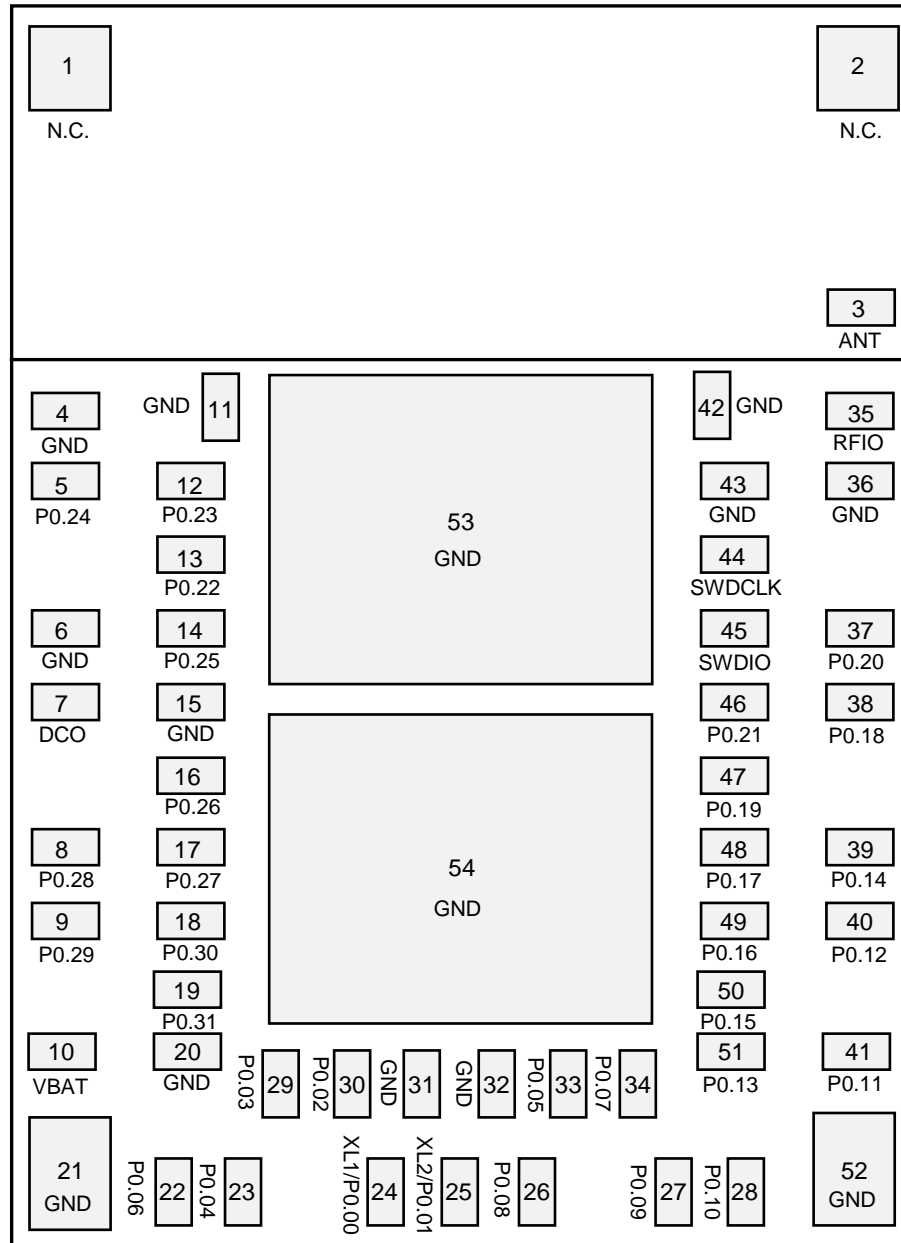

TOP VIEW

■ List of Pins

Pin	Symbol	Function	Attribute/value at reset	Description
1	N.C.	Not Connected	-	Not Connected pin
2	N.C.	Not Connected	-	Not Connected pin
3	ANT	Antenna In/Out	-	Internal antenna port. It should be connected to PAD 35(RF IO) for normal operation.
4	GND	Ground	-	Ground PAD
5	P0.24	Digital I/O	Input	General purpose I/O
6	GND	Ground	-	Ground PAD
7	DCO	Power	-	Test pin(DC/DC converter output) Be sure to use this pin open.
8	P0.28	Digital I/O Analog Input	Input	General purpose I/O SAADC/COMP/LCOMP Input(AIN4)
9	P0.29	Digital I/O Analog Input	Input	General purpose I/O SAADC/COMP/LCOMP Input(AIN5)
10	VBAT	Power	-	Power supply PAD
11	GND	Ground	-	Ground PAD
12	P0.23	Digital I/O	Input	General purpose I/O
13	P0.22	Digital I/O	Input	"General purpose I/O
14	P0.25	Digital I/O	Input	General purpose I/O
15	GND	Ground	-	Ground PAD
16	P0.26	Digital I/O	Input	General purpose I/O
17	P0.27	Digital I/O	Input	General purpose I/O
18	P0.30	Digital I/O Analog Input	Input	"General purpose I/O SAADC/COMP/LCOMP Input(AIN6)
19	P0.31	Digital I/O Analog Input	Input	General purpose I/O SAADC/COMP/LCOMP Input(AIN7)
20	GND	Ground	-	Ground PAD
21	GND	Ground	-	Ground PAD
22	P0.06	Digital I/O	Input	General purpose I/O
23	P0.04	Digital I/O Analog Input	Input	General purpose I/O SAADC/COMP/LCOMP Input(AIN2)
24	XL1	Analog input	-	MK71511: Test Monitor pin:Connection for 32.768 kHz crystal (LFXO)Be sure to use this pin open.
	P0.00	Digital I/O	Input	MK71511A:"General purpose I/O
25	XL2	Analog input	-	MK71511:Test Monitor pin:Connection for 32.768 kHz crystal (LFXO)Be sure to use this pin open.
	P0.01	Digital I/O	Input	MK71511A:"General purpose I/O
26	P0.08	Digital I/O	Input	"General purpose I/O
27	P0.09	Digital I/O	Input	General purpose I/O
28	P0.10	Digital I/O	Input	General purpose I/O
29	P0.03	Digital I/O Analog Input	Input	General purpose I/O SAADC/COMP/LCOMP Input(AIN1)
30	P0.02	Digital I/O Analog Input	Input	General purpose I/O SAADC/COMP/LCOMP Input(AIN0)
31	GND	Ground	-	Ground PAD
32	GND	Ground	-	Ground PAD
33	P0.05	Digital I/O Analog Input	Input	General purpose I/O SAADC/COMP/LCOMP Input(AIN3)
34	P0.07	Digital I/O	Input	"General purpose I/O
35	RFIO	RF In/Out	-	Single-ended radio antenna connection
36	GND	Ground	-	Ground PAD
37	P0.20	Digital I/O	Input	General purpose I/O
38	P0.18	Digital I/O	Input	General purpose I/O
39	P0.14	Digital I/O	Input	General purpose I/O
40	P0.12	Digital I/O	Input	General purpose I/O
41	P0.11	Digital I/O	Input	General purpose I/O
42	GND	Ground	-	Ground PAD
43	GND	Ground	-	Ground PAD

Pin	Symbol	Function	Attribute/value at reset	Description
44	SWDCLK	Digital input	Pull-down	Serial Wire Debug clock for Programming and debug
45	SWDIO	Digital I/O	Pull-up	Serial Wire Debug I/O for Programming and debug
46	P0.21	Digital I/O	Input	General purpose I/O
47	P0.19	Digital I/O	Input	General purpose I/O
48	P0.17	Digital I/O	Input	General purpose I/O
49	P0.16	Digital I/O	Input	General purpose I/O
50	P0.15	Digital I/O	Input	General purpose I/O
51	P0.13	Digital I/O	Input	General purpose I/O
52	GND	Ground	-	Ground PAD
53	GND	Ground	-	Ground PAD
54	GND	Ground	-	Ground PAD

(*)GND=0V

■ Electrical Characteristics

The values in the columns described below as standard indicate typical center values. It is not a guaranteed value that takes into account variations.

● Absolute Maximum Ratings

Item	Symbol	Condition	Min	Max	Unit
Power supply voltage	VBAT	—	-0.3	3.9	V
	GND	—	-	0	V
Input voltage	VIN	VBAT ≤ 3.6V	-0.3	VBAT+0.3	V
		VBAT >3.6V	-0.3	3.9	V
Input power	RFIO	—	-	10	dBm
Storage temperature	T _{stg}	—	-40	85	°C
Flash memory endurance	—	—	10000	-	Write/erase cycles

(*)GND=0V

● Recommended Operating Conditions

Item	Symbol	Condition	Min.	Standard	Max.	Unit
Power supply voltage	VBAT	—	1.70	3.00	3.60	V
Power supply rise time	tR_VBAT	Supply rise time (0V to 1.7V) *1	-	-	60	Ms
Operating temperature	T _a	—	-40	+25	+85	°C

(*)GND=0V

*1 If the power supply rise time (tR_VBAT) is exceeded, the power-on reset circuit in the nRF52811 may not operate properly. Also, when turning on the power after turning off the power, be sure to drop it to 0.3V or less before starting up.

● Current consumption

(Ta=25°C)

Item	Symbol	Condition	Min.	Standard	Max.	Unit
Current consumption of RX	IRX_1Mbps	RX only run current (1Mbps)	—	4.6	—	mA
	IRX_2Mbps	RX only run current (2Mbps)	—	5.2	—	mA
	IRADIO_RX1Mbps	Bluetooth Low Energy mode (1Mbps)	—	6.1	—	mA
Current consumption of TX	ITX_0dBm	TX only run current (0dBm)	—	4.6	—	mA
	ITX_4dBm	TX only run current (+4dBm)	—	7.0	—	mA
	IRADIO_TX0dBm	Bluetooth Low Energy mode (0dBm)	—	5.8	—	mA
Current consumption at low power	IOFF	System Off, No RAM Retention	—	0.3	—	uA
	IRAM	System Off, 24kB RAM Retention	—	0.5	—	uA
	ION	System On, No RAM Retention	—	1.0	—	uA

(*) VBAT=3.0V, GND=0V

● DC Characteristics

(Ta=25°C)

Item	Symbol	Condition	Min.	Standard	Max.	Unit
High-level input voltage	VIH	—	VBAT X0.7	—	VBAT	V
Low-level input voltage	VIL	—	GND	—	VBAT X0.3	V
High-level output voltage	VOH	IOH=5mA	VBAT - 0.4	—	VBAT	V
Low-level output voltage	VOL	IOL=5mA	GND	—	GND +0.4	V

(*) VBAT=3.0V, GND=0V

(*)The target pin is a digital input / digital output pin

● RF Characteristics

(Ta=25°C)

Item	Symbol	Condition	Min.	Standard	Max.	Unit
Transmitter						
Operating frequencies	fOP	—	2402	—	2480	MHz
Frequency deviation	fDELTA,BLE,1 M	BLE 1Msps	—	±250	—	kHz
Frequency deviation	fDELTA,BLE,2 M	BLE 2 Msps	—	±500	—	kHz
Maximum output power	PRF	—	—	4	—	dBm
RF power control range	PRFC	—	—	24	—	dB
RF power accuracy	PRFCR	—	—	—	±4	dB
Receiver						
Maximum received signal strength	PRX,MAX	at < 0.1% BER	—	0	—	dBm
Receiver Sensitivity	PSENS,IT,SP, 1M,BLE	1Msps BLE ideal transmitter, <=37 bytes BER=0.1%	—	-97	—	dBm
	PSENS,IT,SP, 2M,BLE	2Msps BLE ideal transmitter, <=37 bytes BER=0.1%	—	-94	—	dBm
	PSENS,IT,BLE LE125k	Sensitivity, 125 kbps BLE mode	—	-104	—	dBm
	PSENS,IT,BLE LE500k	Sensitivity, 500 kbps BLE mode	—	-100	—	dBm

(*) VBAT=3.0V, GND=0V

■ Module Dimension

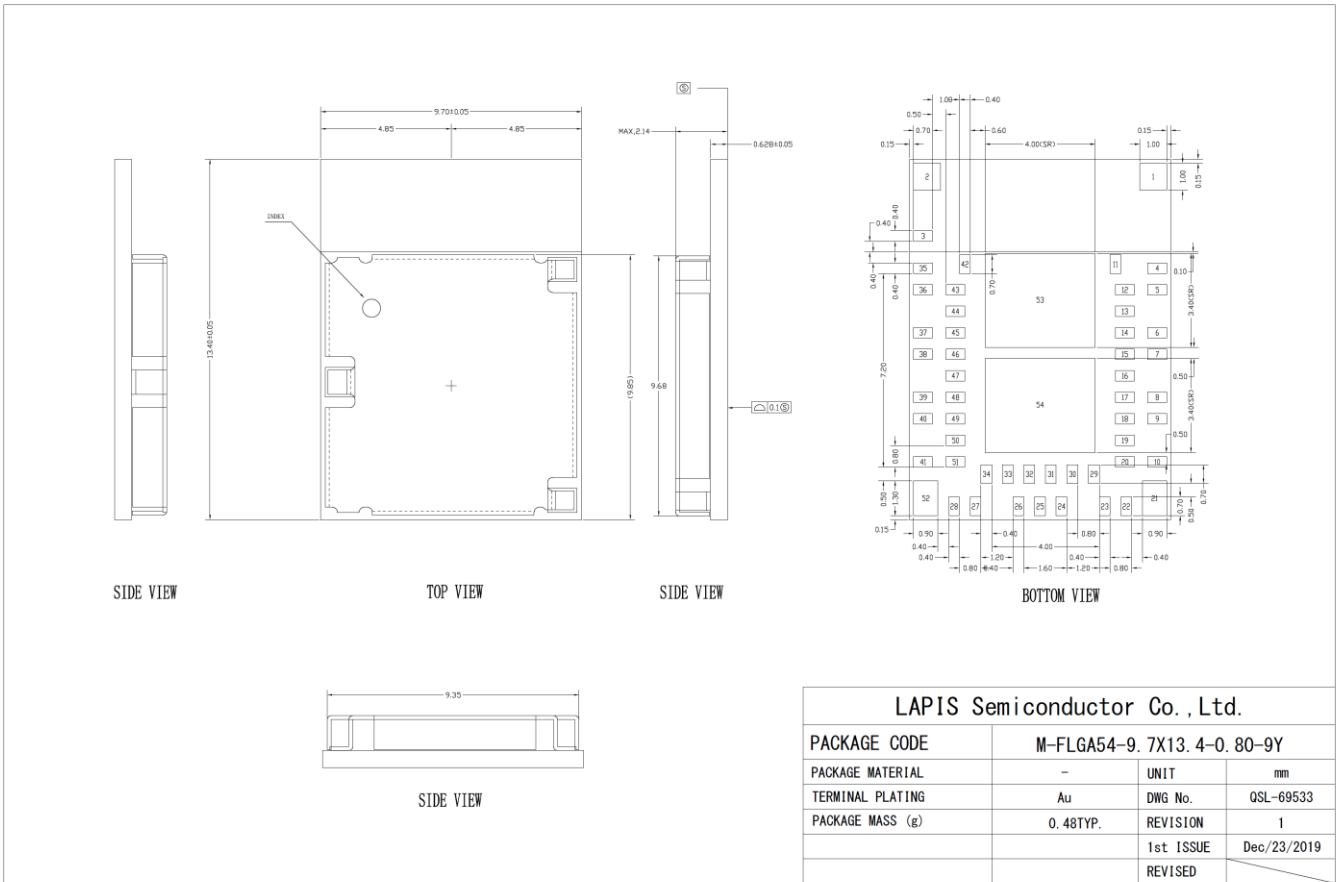

Remarks for Mounting the Surface Mount Type Package

Surface mount type package is very sensitive affected by heating from reflow process, humidity during storage. Therefore, before you perform reflow mounting, contact sales office for the product name, package name, pin number, package code and desired mounting conditions (reflow method, temperature and times) and storage environment.

■ Examples of Application Circuit

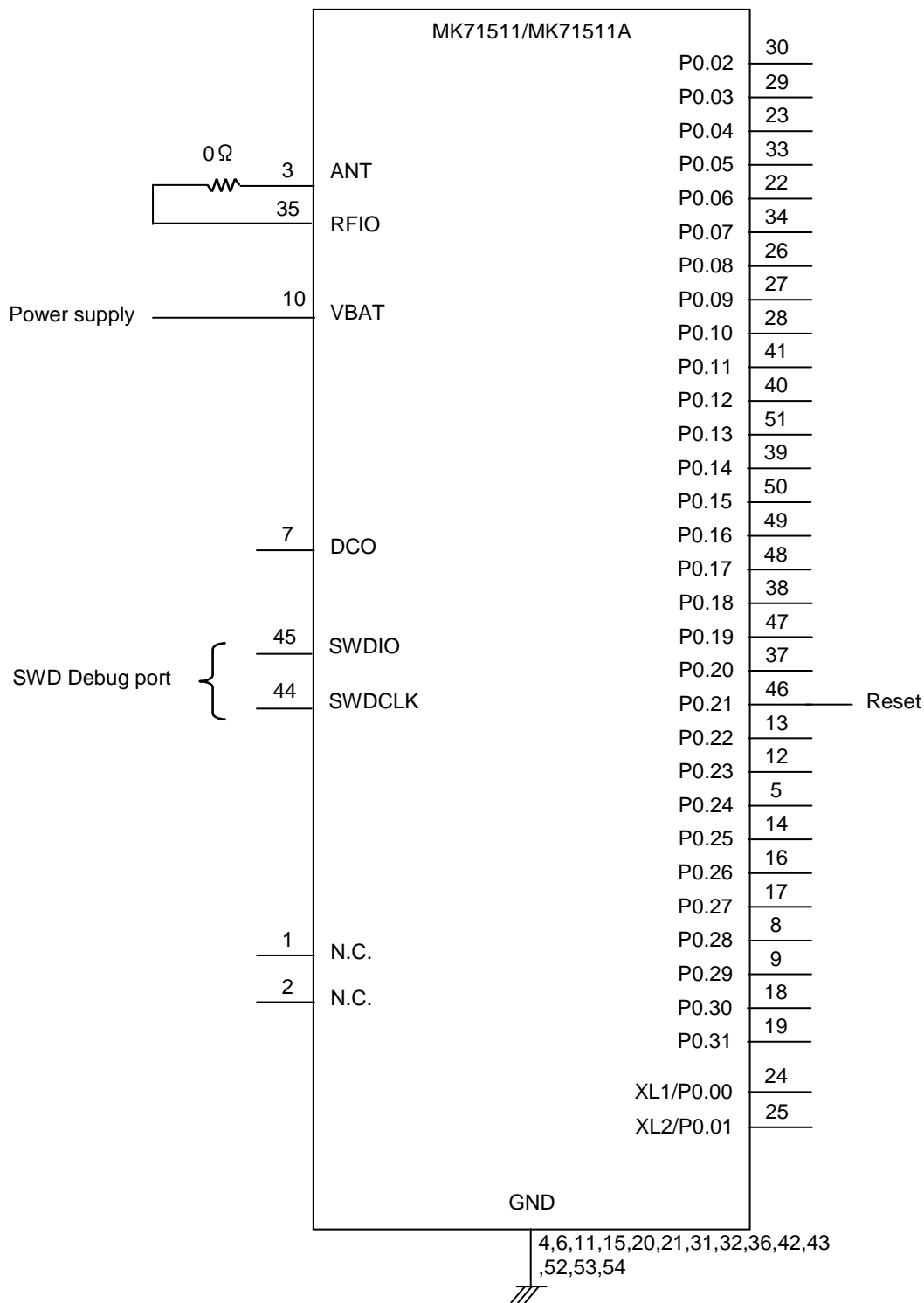

•Unused pins should be "N.C." pin.

■ Appendix

● Radio Certification

MIC JAPAN (certification no: 006-000797 [MK71511] / 006-000799 [MK71511A])

MK71511/MK71511A complies with MIC JAPAN radio certification.

FCC (FCC ID: 2ACIJ71511)

This device complies with Part 15 of the FCC Rules.

Operation is subject to the following two conditions:

(1) this device may not cause harmful interference, and (2) this device must accept any interference received, including interference that may cause undesired operation.

The regulatory label on the final system must include the statement: "Contains FCC ID: 2ACIJ71511" or using electronic labeling method as documented in KDB 784748.

This equipment complies with FCC radiation exposure limits set forth for an uncontrolled environment.

The antenna used for this transmitter must not be collocated or operating in conjunction with any other antenna or transmitter within a host device, except in accordance with FCC multi-transmitter product procedures.

The final system integrator must ensure there is no instruction provided in the user manual or customer documentation indicating how to install or remove the transmitter module except such device has implemented two-ways authentication between module and the host system.

OEM Responsibilities to comply with FCC Regulations

This module has been certified for integration into products only by OEM integrators under the following condition:

- The transmitter module must not be collocated or operating in conjunction with any other antenna or transmitter.

As long as the conditions above are met, further transmitter testing will not be required. However, the OEM integrator is still responsible for testing their end-product for any additional compliance requirements required with this module installed (for example, digital device emissions, PC peripheral requirements, etc.).

IMPORTANT NOTE:

In the event that any of these conditions can not be met (for example the reference trace specified in this manual, or use of a different antenna), then the FCC authorization is no longer considered valid and the FCC ID can not be used on the final product. In these circumstances, the OEM integrator will be responsible for re-evaluating the end product (including the transmitter) and obtaining a separate FCC authorization.

Changes or modification not expressly approved by the party responsible for compliance could void the user's authority to operate the equipment.

NOTE: This equipment has been tested and found to comply with the limits for a Class B digital device, pursuant to part 15 of the FCC Rules. These limits are designed to provide reasonable protection against harmful interference in a residential installation. This equipment generates, uses and can radiate radio frequency energy and, if not installed and used in accordance with the instructions, may cause harmful interference to radio communications. However, there is no guarantee that interference will not occur in a particular installation. If this equipment does cause harmful interference to radio or television reception, which can be determined by turning the equipment off and on, the user is encouraged to try to correct the interference by one or more of the following measures:

- Reorient or relocate the receiving antenna.
- Increase the separation between the equipment and receiver.
- Connect the equipment into an outlet on a circuit different from that to which the receiver is connected.
- Consult the dealer or an experienced radio/TV technician for help.

ISED (IC: 20971-71511)

This device complies with ISED(Innovation, Science and Economic Development Canada)'s licence-exempt RSSs. Operation is subject to the following two conditions:

- (1) This device may not cause interference; and
- (2) This device must accept any interference, including interference that may cause undesired operation of the device.

Le présent appareil est conforme aux CNR d' ISED(Innovation, Science and Economic Development Canada) applicables aux appareils radio exempts de licence. L'exploitation est autorisée aux deux conditions suivantes :

- (1) l'appareil ne doit pas produire de brouillage;
- (2) l'utilisateur de l'appareil doit accepter tout brouillage radioélectrique subi, même si le brouillage est susceptible d'en compromettre le fonctionnement.

The regulatory label on the final system must include the statement: "Contains IC: 20971-71511".

Due to the model size the IC identifier is displayed in this manual only and can not be displayed on the modules label due to the limited size.

CE (RED)

MK71511/MK71511A complies with the radio test requirements (EN 300 328 V2.1.1) ,which is based on the RE Directive. EMC and Safety test that is required for the CE marking should be done in the final end-product.

● Bluetooth® Qualification (RF-PHY)

MK71511/MK71511A is listed on the Bluetooth SIG website as qualified RF-PHY Component.
(Declaration ID:D049594, QDID:146733)

When selling the final product using this module, please perform End Product Listing of customer product based on the certification of this module and certification of Nordic softDevice.

■ Note

- When mounting this product on the double-sided board, do not mount it on the initial mounting side.
(Reflow on the other side from the module mounting side is prohibited.)
- Due to its material characteristic, the sealed case may change color. However, this does not affect the product performance and its quality.
- Please contact a ROHM sales office for guidelines on board design.

■ Related Documents

The following related documents are available and should be referenced as needed.

<nRF52811 related documents >

- nRF52811_Product Specification (https://infocenter.nordicsemi.com/pdf/nRF52811_PS_v1.0.pdf)

■ Revision History

Document No.	Date	Page		Description
		Previous Edition	Current Edition	
FEDK71511-01	Apr 9,2020	—	—	1st Edition
FEDK71511-02	May 20,2020	4-5	4-5	Updated pin description in pin list. (added description of AIN0-AIN7)

Notes

Precautions for the Specification

- 1) Contents of the Specification are the information at the time of their issuance. The information contained herein is subject to change without notice.
- 2) LAPIS Semiconductor has used reasonable care in preparing the information included in the Specification, but LAPIS Semiconductor does not warrant that such information is error free. LAPIS Semiconductor assumes no liability whatsoever for any damages incurred by you resulting from errors in or omissions from the information included herein.
- 3) The technical information specified herein is intended only to show the typical functions of the Products and examples of application circuits for the Products. No license, expressly or implied, is granted hereby under any intellectual property rights or other rights of LAPIS Semiconductor or any third party with respect to the information contained in this document; therefore LAPIS Semiconductor shall have no responsibility whatsoever for any dispute, concerning such rights owned by third parties, arising out of the use of such technical information.
- 4) The Specification contains information related to the LAPIS Semiconductor's copyright and technical know-how. Any use of them other than pertaining to the usage of appropriate products is not permitted. Further, the Specification, in part or in whole, may not be reprinted or reproduced and disclosed to third parties without prior consent of LAPIS Semiconductor.

Precautions for the Products

●Precautions for Safety

- 1) The Products are designed and produced for application in ordinary electronic equipment (AV equipment, OA equipment, telecommunication equipment, home appliances, amusement equipment, etc.).
- 2) For use of our Products in applications requiring a high degree of reliability (as exemplified below), please contact and consult with a LAPIS Semiconductor representative: transportation equipment (i.e. cars, ships, trains), primary communication equipment, traffic lights, fire/crime prevention, safety equipment, medical systems, servers, solar cells, and power transmission systems.
- 3) Do not use our Products in applications requiring extremely high reliability, such as aerospace equipment, nuclear power control systems, and submarine repeaters.
- 4) The Products are designed for use in a standard environment and not in any special environments. Application of the Products in a special environment can deteriorate product performance. Accordingly, verification and confirmation of product performance, prior to use, is recommended if used under the following conditions:
 - [a] Use in various types of liquid, including water, oils, chemicals, and organic solvents
 - [b] Use outdoors where the Products are exposed to direct sunlight, or in dusty places
 - [c] Use in places where the Products are exposed to sea winds or corrosive gases, including Cl₂, H₂S, NH₃, SO₂, and NO₂
 - [d] Use in places where the Products are exposed to static electricity or electromagnetic waves
 - [e] Use in environment subject to strong vibration and impact.
 - [f] Use in proximity to heat-producing components, plastic cords, or other flammable items
 - [g] Use involving sealing or coating the Products with resin or other coating materials
 - [h] Use of the Products in places subject to dew condensation
 - [i] Use in an environment where the temperature is always low, such as in a freezer
- 5) The Products might receive the radio wave interference from electronic devices such as Wireless LAN devices, Bluetooth devices, digital cordless telephone, and microwave oven and so on that radiate electromagnetic wave.
- 6) The Products are not radiation resistant.
- 7) Verification and confirmation of performance characteristics of Products, after on-board mounting, is advised.
- 8) Confirm that operation temperature is within the specified range described in the Specification.

- 9) Although LAPIS Semiconductor is continuously working to improve product reliability and quality, semiconductors can break down and malfunction due to various factors. Therefore, if product malfunctions may result in serious damage, including that to human life, sufficient fail-safe measures must be taken, including the following:
- [a] Installation of protection circuits or other protective devices to improve system safety
 - [b] Installation of redundant circuits in the case of single-circuit failure
- 10) Failure induced under deviant condition from what defined in the Specification cannot be guaranteed.
- 11) This product is a specification to radiate the radio wave. It is necessary to acquire the attestation of decided Radio Law of each region used to use the equipment that radiates the radio wave.
Please inquire about the attestation of Radio Law that this product acquires.
- 12) When product safety related problems arises, please immediately inform to LAPIS Semiconductor, and consider technical counter measure.

● Precautions for Reference Circuits

- 1) If change is made to the constant of an external circuit, allow a sufficient margin due to variations of the characteristics of the Products and external components, including transient characteristics, as well as static characteristics.
- 2) The reference circuit examples, their constants, and other types of information contained herein are applicable only when the Products are used in accordance with standard methods. Therefore, if mass production is intended, sufficient consideration to external conditions must be made.

● Precaution for Electrostatic

This product is Electrostatic sensitive product, which may be damaged due to Electrostatic discharge. Please take proper caution during manufacturing and storing so that voltage exceeding Product maximum rating won't be applied to the Products. Please take special care under dry condition (Grounding of human body / equipment / solder iron, isolation from charged objects, setting of Ionizer, friction prevention and temperature / humidity control etc.)

● Precautions for Storage / Transportation

- 1) Product performance and connector mating may deteriorate if the Products are stored in the following places:
 - [a] Where the Products are exposed to sea winds or corrosive gases, including Cl₂, H₂S, NH₃, SO₂ and NO₂
 - [b] Where the temperature or humidity exceeds those recommended by LAPIS Semiconductor
Temperature: 5°C to 40°C, Humidity 40% to 60%
 - [c] Storage in direct sunshine or condensation.
 - [d] Storage in high Electrostatic.
- 2) Even under LAPIS Semiconductor recommended storage condition, connector mating, mountability, and heat resistance of products over 1 year old may be degraded.
- 3) Store / transport cartons in the correct direction, which is indicated on a carton as a symbol, otherwise bent leads may occur due to excessive stress applied when dropping of a carton.

● Precaution for Product Label

QR code printed on LAPIS Semiconductor product label is only for internal use, and please do not use at customer site. It might contain internal products information that is inconsistent with product information.

● Precaution for Disposition

When disposing products, please dispose them properly with an industry waste company.

● Prohibition Regarding Intellectual Property

LAPIS Semiconductor prohibits the purchaser of the Products to exercise or use the intellectual property rights, industrial property rights, or any other rights that either belong to or are controlled by LAPIS Semiconductor, other than the right to use, sell, or dispose of the Products.

● The other precautions

- 1) Please use the Products in accordance with any applicable environmental laws and regulations, such as the RoHS Directive. For more details, including RoHS compatibility, please contact a ROHM sales office. LAPIS Semiconductor shall have no responsibility for any damages or losses resulting non-compliance with any applicable laws or regulations.
- 2) When providing our Products and technologies contained in the Specification to other countries, you must abide by the procedures and provisions stipulated in all applicable export laws and regulations, including without limitation the US Export Administration Regulations and the Foreign Exchange and Foreign Trade Act.

Copyright 2020 LAPIS Semiconductor Co., Ltd.

LAPIS Semiconductor Co.,Ltd.

2-4-8 Shinyokohama, Kouhoku-ku,
Yokohama 222-8575, Japan
<http://www.lapis-semi.com/en/>