



Dear customer

ROHM Co., Ltd. ("ROHM"), on the 1st day of April, 2024,
has absorbed into merger with 100%-owned subsidiary of LAPIS Technology Co., Ltd.

Therefore, all references to "LAPIS Technology Co., Ltd.", "LAPIS Technology"
and/or "LAPIS" in this document shall be replaced with "ROHM Co., Ltd."

Furthermore, there are no changes to the documents relating to our products other than
the company name, the company trademark, logo, etc.

Thank you for your understanding.

ROHM Co., Ltd.
April 1, 2024

ML22530

4-Channel Mixing Speech Synthesis LSI for Automotive

Overview

ML22530 is a 4-channel mixing speech synthesis LSI with a serial audio interface and a serial flash memory interface for sound data.

It adopts a HQ-ADPCM^{*1}, 16-bit D/A converter, and low-pass filter for high sound quality, and incorporates a 1.0W mono speaker amplifier for driving speakers directly. It is also equipped with a function to detect failure.

The functions necessary for sound output are integrated into a single chip, so that sound functions can be realized simply by adding this LSI.

- Memory capacity and maximum sound production time (HQ-ADPCM^{*1} algorithm, registered phrase 1024)

Product Name	Flash memory capacity	Maximum sound production time (sec)		
		f _s =8.0kHz	f _s =16.0kHz	f _s =32.0kHz
ML22530	128Mbits (Serial Flash Memory)	5240	2620	1310

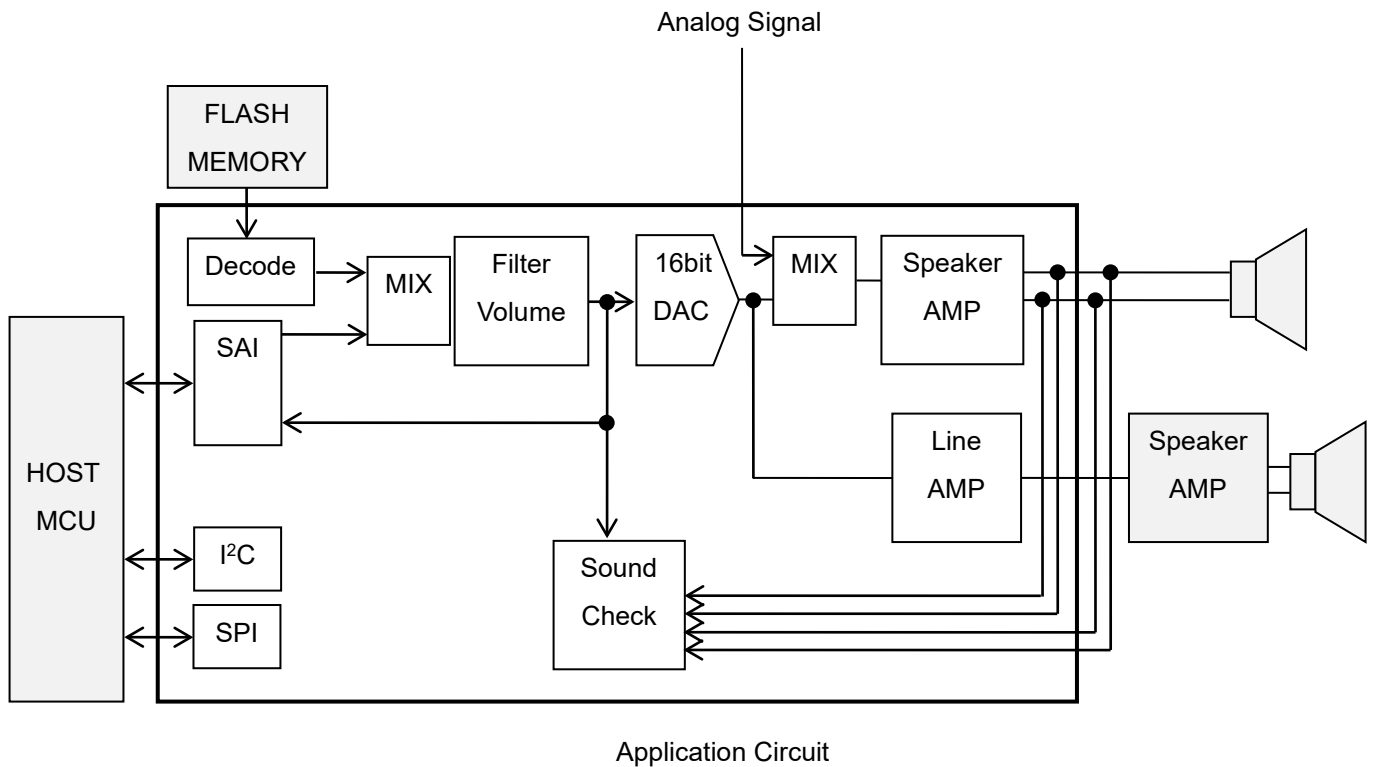

*1  Ky's Technology

HQ-ADPCM is "Ky's" high-quality audio compression technique. "Ky's" is a registered trademark of Kyushu Institute of Technology, a national university corporation.

■ Feature

- Sound data
 - Speech synthesis algorithm: The algorithm can be specified for each phrase.
HQ-ADPCM/4bit ADPCM/8bit non-linear PCM /
8bit Straight PCM/16bit Straight PCM
 - Sampling frequency: The sampling frequency can be specified for each phrase.
10.7/21.3kHz,
6.4/12.8/25.6kHz,
8.0/16.0/32.0kHz,
11.025/22.05/44.1kHz,
12.0/24.0/48.0kHz
 - Maximum number of phrases: 4096 Phrases
- Edit ROM function
- Playback function
 - Repeat function: LOOP command
 - Mixing-function: Up to 4-channel *1
 - Volume adjustment function: CVOL command 128 levels (including off-state)
AVOL command 16 levels (including off-state)
- Serial audio interface (slave)
 - PCM format: 8bit Straight PCM/16bit Straight PCM
 - Sampling frequency: 8.0/16.0/32.0kHz,
11.025/22.05/44.1kHz,
12.0/24.0/48.0kHz
 - Data length: 8bit/16bit
 - BCLK frequency: 32fs to 64fs
 - LRCLK transfer mode
LRCLK forward/reverse selectable
 - 1-bit delay ON/OFF selectable
 - MSB first/LSB first selectable
- Low-pass filter
- 16-bit D/A converter
- Speaker amplifier: Class AB 1.0W 8Ω (SPV_{DD} = 5V, Ta = 25 °C)
- Line amplifier output: 10kΩ driving (Exclusive operation from speaker amplifier output)
- External analog sound input (with analog mixing function)
- MCU command interface: Clock Synchronous Serial Interface/I²C Interface (Slave)
- Failure detection function
 - Playback sound error detection
 - Speaker short detection: Speaker pin ground fault detection, speaker pin short detection
 - Speaker disconnection detection
 - Thermal detection
 - Clock error detection
 - Flash memory error detection
- Clock backup function
- Master clock frequency: 4.096MHz, 4.000MHz
- Power-supply voltage: 2.7V to 5.5V
DV_{DD}, SPV_{DD}/SPOV_{DD} and IOV_{DD} can be set independently.
(SPV_{DD} = SPOV_{DD} ≥ DV_{DD})
- Operating temperature range: -40 °C to +105 °C*2

*1 Mixing with SAI is limited by the sampling frequency. Refer to the "Function description".

*2 The operating time of the speaker amplifier may be limited depending on the average ambient temperature (Ta) used.

■ Applications

- Automotive equipment (e.g., AVAS(Acoustic Vehicle Alerting System), Meter cluster, Various warning sounds) .
- Consumer and Industrial equipment (e.g., Household appliances, Housing equipment, Office equipment, Measurement instrumentation, etc.).

【NOTE】

This product cannot be applicable for automatic train control systems, and railway safety systems. Please contact ROHM sales office in advance if contemplating the integration of this product into applications that requires high reliability, such as transportation equipment for ships and railways, communication equipment for trunk lines, traffic signal equip.

■ Table format

Package	Body size (including lead) [mm × mm]	Pin pitch [mm]	Packing form and Product name	
			Tray	Tape & Reel
48 pin plastic TQFP	7.0 × 7.0 (9.0 × 9.0)	0.50	ML22530TBZ0AX	ML22530TBZ0BX

*1 “NNN” is a blank product. “xxx” denotes ROM code number.

■ Pin Configuration (TOP VIEW)

● ML22530TB

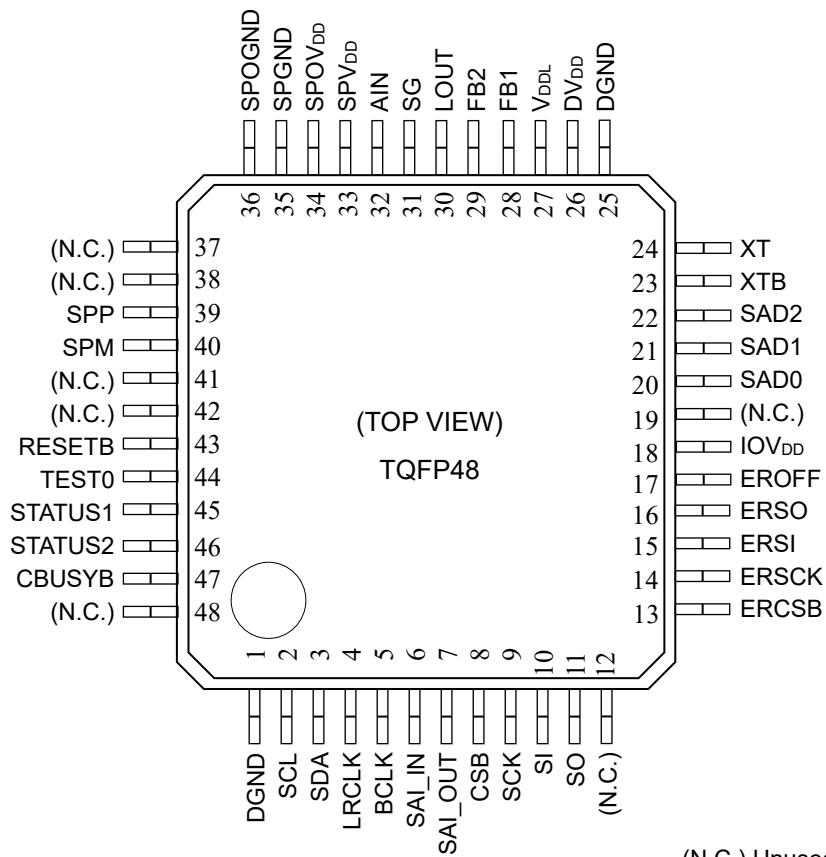

(N.C.) Unused pin

■ Pin Description

Pin	Symbol	I/O	Attribute	Description	Initial value *1
1,25	DGND	G	-	Digital ground pin.	—
2	SCL	I	-	I ² C slave serial clock pin. When using an I ² C, be sure to insert a pull-up resistor between DV _{DD} pin. Accessing with synchronous serial interface at the same time is prohibited.	H
3	SDA	IO	-	I ² C slave serial data input/output pin. When using an I ² C, be sure to insert a pull-up resistor between DV _{DD} pin. Output: Nch MOS OPEN DRAIN output Input: High-impedance input Accessing with synchronous serial interface at the same time is prohibited.	H
4	LRCLK	I	-	SAI word clock input pin.	L
5	BCLK	I	-	SAI bit clock input pin.	L
6	SAI_IN	I	-	SAI bit data input pin. The data are loaded at the rising edges of BCLK.	L
7	SAI_OUT	O	-	SAI bit data output pin. Output data at the falling edge of BCLK.	L
8	CSB	I	Negative	Synchronous serial interface chip select pin. The SCK and SI inputs are accepted only when this pin is at the "L" level. Accessing with I ² C slave interfaces at the same time is prohibited.	H
9	SCK	I	-	Synchronous serial interface clock input pin. Accessing with I ² C slave interfaces at the same time is prohibited.	L
10	SI	I	-	Synchronous serial interface data input pin. Data is fetched in synchronization with SCK. Accessing with I ² C slave interfaces at the same time is prohibited.	L
11	SO	O	-	Synchronous serial interface data output pin. When the CSB pin is at an "L" level, data is output in synchronization with SCK. When the CSB pin is at an "H" level, this pin enters a high-impedance state. Accessing with I ² C slave interfaces at the same time is prohibited.	Hi-Z
13	ERCSB	O	Negative	Serial flash memory interface chip select output pin. Output the "H" level during non-access and the "L" level during access. Setting the EROFF pin to "L" enables output.	H*2
14	ERSCK	O	-	Serial flash memory interface serial clock output pin. Setting the EROFF pin to "L" enables output.	L*2
15	ERSI	I	-	Serial flash memory interface serial data input pin. Setting the EROFF pin to "L" enables input. A pull-down resistor is internally connected.	L
16	ERSO	O	-	Serial flash memory interface serial data output pin. Setting the EROFF pin to "L" enables output.	L*2
17	EROFF	I	Positive	Pin to disable the serial flash memory interface. When this bit is set to "L", the serial flash memory interface pin is enabled. A pull-down resistor is internally connected. Set this pin to "L" during playback operation using serial flash memory. When this pin set to "H", the serial flash memory interface is in a condition of high-impedance. Set this bit to "H" for onboard rewriting.	L

*1 Initial value at reset input and power-down. The pin whose IO is "I" indicates a fixed level from outside.

*2 If an error in the Flash memory is detected, initial value will be output.

Pin	Symbol	I/O	Attribute	Description	Initial value *1
18	IOV _{DD}	P	-	Serial flash memory interface power supply pin. Connect to DV _{DD} pin even when not using serial flash memory interface. Connect a bypass capacitor between this pin and the DGND pin.	—
20	SAD0	I	-	I ² C slave address select pin.	—
21	SAD1	I	-	I ² C slave address select pin.	—
22	SAD2	I	-	I ² C slave address select pin.	—
23	XTB	O	Negative	Crystal or ceramic resonator connection pin. When an external clock is used, leave it open and capacitor is not required when a crystal or ceramic resonator is connected. When using a resonator, connect it as close as possible. Leave it open when not in use.	H
24	XT	I	Positive	Crystal or ceramic resonator connection pin. A feedback resistor of about 1MΩ is built in between the XT pin and the XTB pin. To use an external clock, input from this pin. Delete the capacitor when a crystal or ceramic resonator is connected. When using a resonator, connect it as close as possible. Leave it open when not in use.	L
26	DV _{DD}	P	-	Digital power supply pin. Connect a bypass capacitor between this pin and the DGND pin.	—
27	V _{DDL}	O	-	2.5V regulator output pin. Used as internal power supply. Connect a capacitor between this pin and DGND pin as close as possible.	L
28	FB1	I	-	Analog input pin 1 for playback sound error detection.	L
29	FB2	I	-	Analog input pin 2 for playback sound error detection.	L
30	LOUT	O	-	This pin is used exclusively for line amplifier output.	L
31	SG	O	-	Reference voltage output pin for the built-in speaker amplifier. Connect a capacitor between this pin and SPGND pin.	L
32	AIN	I	-	Speaker amplifier analog signal input pin. Initially, input is disabled.	L
33	SPV _{DD}	P	-	Power supply pin for speaker amplifier. Connect a bypass capacitor between this pin and the SPGND pin.	—
34	SPOV _{DD}	P	-	Power supply pin for the speaker amplifier output circuit. Set it at the same potential as the SPV _{DD} pin.	—
35	SPGND	G	-	Speaker amplifier ground pin.	—
36	SPOGND	G	-	Ground pin for the speaker amplifier output circuit. Set it at the same potential as the SPGND pin.	—
39	SPP	O	-	Positive output pin of the speaker amplifier. Line amplifier outputs are also available with AMODE command.	L
40	SPM	O	-	Negative output pin of the speaker amplifier.	Hi-Z

*1 Initial value at reset input and power-down. The pin whose IO is "I" indicates a fixed level from outside.

Pin	Symbol	I/O	Attribute	Description	Initial value *1
43	RESETB	I	Negative	Reset input pin. The LSI is initialized by the "L" level input. After a reset is input, all the circuits stop operating and enter the power-down state. At power-on, input an "L" level to this pin. After the power supply voltage stabilizes, set this pin to an "H" level. A pull-up resistor is internally connected.	(²)
44	TEST0	I	Positive	Input pin for testing. A pull-down resistor is internally connected. Fix to the DGND.	L
45	STATUS1	O	-	Status/error output pin 1. Execute OUTSTAT command to select BUSYB* ³ and NCR* ³ in each channel, or errors. The initial value is BUSYB* ³ of channel 0, and output data is "H" level.	H
46	STATUS2	O	-	Status/error output pin 2. Execute OUTSTAT command to select BUSYB* ³ and NCR* ³ in each channel, or errors. The initial value is BUSYB* ³ of channel 0, and output data is "H" level.	H
47	CBUSYB	O	Negative	Command processing status signal output pin. An "L" level is output during command processing. Be sure to input a command with this pin at an "H" level.	(²)
12,19,37, 38,41, 42,48	N.C.	-	-	Unused pin. Leave open.	Hi-Z

*1 Initial value at reset input and power-down. The pin whose IO is "I" indicates a fixed level from outside.

*2 "L" at reset, "H" at power-down

*3 For NCR, BUSYB, refer to the description of "RDSTAT command".

■ Termination of Unused Pins

This section explains how to terminate unused pins.

Symbol	Recommended pin termination
SCL	Connect to the DV _{DD} .
SDA	
SAD0	Connect to the DGND.
SAD1	
SAD2	
LRCLK	Connect to the DGND.
BCLK	
SAI_IN	
CSB	Connect to the DV _{DD} .
SCK	Connect to the DGND.
SI	
EROFF	Connect to the DGND.
XT	Leave open.
XTB	
FB1	Connect to the SP _{GND} .
FB2	
AIN	Connect to the SP _{GND} .
TEST0	Connect to the DGND.
N.C.	Leave open.
SAI_OUT	Leave open.
SO	
LOUT	
SPP	
SPM	
STATUS1	
STATUS2	

■ I/O Equivalent Circuit

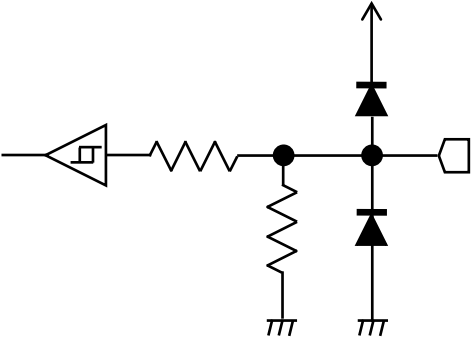
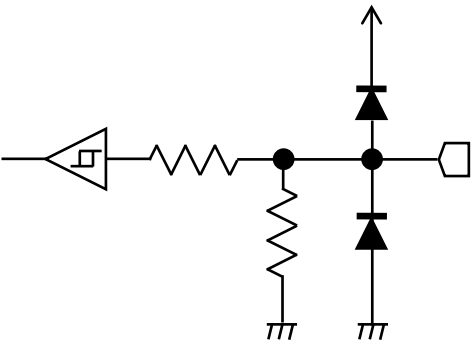
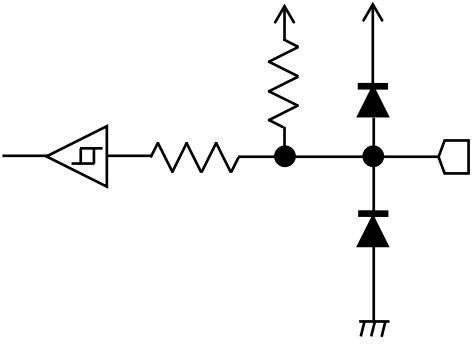
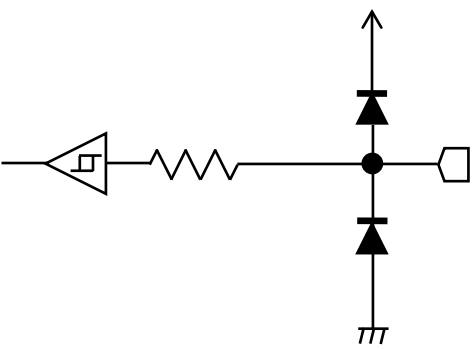
Classification	Circuit	Overview
A		<p>Attribute: Input Power: DV_{DD} Function: CMOS inputs with pull-down Applicable pin: TEST0</p>
B		<p>Attribute: Input Power: IOV_{DD} Function: CMOS inputs with pull-down Applicable pin: EROFF</p>
C		<p>Attribute: Input Power: DV_{DD} Function: CMOS inputs with pull-up Applicable pin: RESETB</p>
D		<p>Attribute: Input Power: DV_{DD} Function: CMOS inputs Applicable pins: SI SCK, CSB, SAD0, SAD1, SAD2, LRCLK, BCLK, SAI_IN</p>

Classification	Circuit	Overview
F		<p>Attribute: output Power: DV_{DD} Function: CMOS outputs Applicable pins: STATUS1, STATUS2, CBUSYB, SO, SAI_OUT</p>
G		<p>Attribute: output Power: IOV_{DD} Function: CMOS outputs Applicable pin: ERCSB, ERSCK, ERSO</p>
H		<p>Attribute: Input Power: IOV_{DD} Function: CMOS inputs with pull-down Applicable pin: ERSI</p>
I		<p>Attribute: Oscillator circuit Power: DV_{DD} Function: 4.096M, 4.000MHz oscillation Applicable pins: XT, XTB</p>

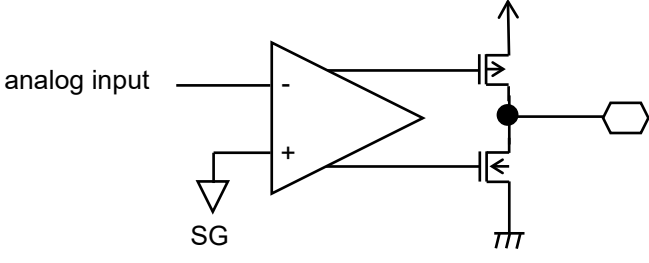
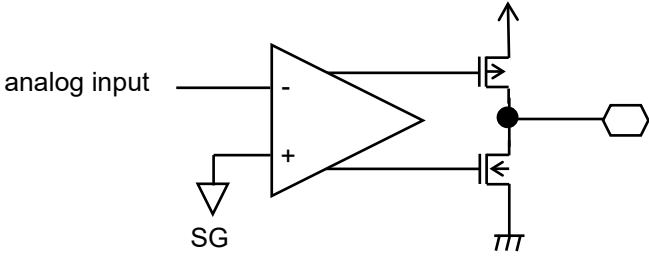
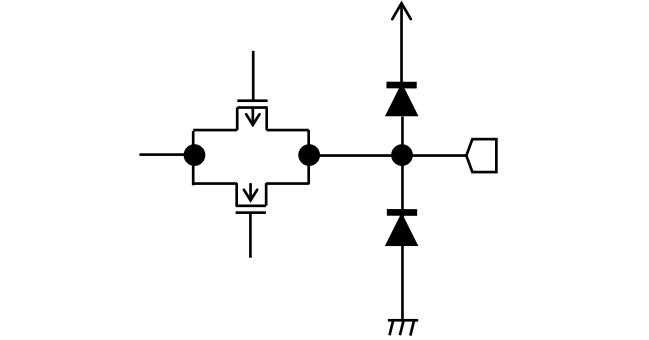
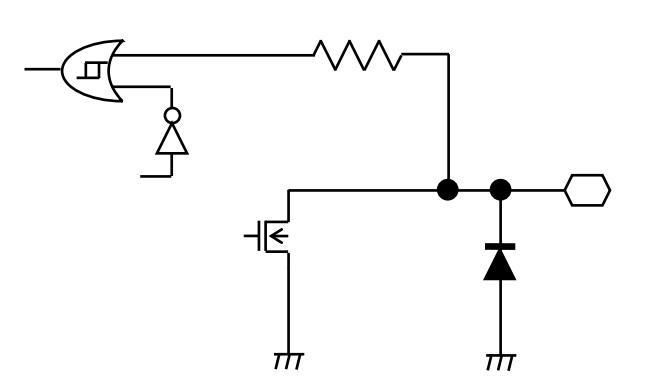
Classification	Circuit	Overview
J		<p>Attribute: Analog Power: $SPOV_{DD}$ Function: Sound output Applicable pins: SPP, SPM</p>
K		<p>Attribute: Analog Power: SPV_{DD} Function: Sound output Applicable pin: LOUT</p>
L		<p>Attribute: Analog Power: SPV_{DD} Function: Sound input Applicable pins: AIN, FB1, FB2</p>
M		<p>Attribute: Input Power: DV_{DD} Function: Nch Open Drain Applicable pins: SCL, SDA</p>

■ Electrical characteristics

● Absolute maximum rating

DGND=SPGND=SPOGND=0V, Ta=25°C

Parameter	Symbol	Condition	Rating	Unit
Power supply voltage 1	DV _{DD} IOV _{DD} SPV _{DD} SPOV _{DD}	—	-0.3 to +6.0	V
Input voltage 1	V _{IN1}	—	-0.3 to DV _{DD} +0.3	V
Input voltage 2	V _{IN2}	—	-0.3 to IOV _{DD} +0.3	V
Input voltage 3	V _{IN3}	Applies to the FB1 and FB2 pins.	-0.3 to SPV _{DD} +0.3	V
Allowable loss	P _D	When the LSI is mounted on JEDEC 4-layer board. SPV _{DD} = SPOV _{DD} = 5V	1000	mW
Output short-circuit current	I _{OS}	Applies to pins other than SPM, SPP and V _{DDL} pins.	10	mA
		Applies to SPM and SPP pins.	500	mA
		Applies to the V _{DDL} pin.	50	mA
Storage temperature	T _{STG}	—	-55 to +150	°C

● Recommended operating conditions

DGND=SPGND=SPOGND=0V

Parameter	Symbol	Condition	Range	Unit	
DV _{DD} , IOV _{DD} , SPV _{DD} *1, SPOV _{DD} *1 Power-supply voltage	DV _{DD} IOV _{DD} SPV _{DD} SPOV _{DD}	—	2.7 to 3.6 / 3.3 to 5.5	V	
Operating temperature	T _{OP}	—	-40 to +105	°C	
Master clock frequency	f _{OSC}	—	Min.	MHz	
			Typ.		4.096
			-5%		4.000
			Max.		
			Typ		
			+5%		

*1 SPV_{DD}=SPOV_{DD}≥DV_{DD}

● DC characteristics

SPV_{DD}=SPOV_{DD}≥DV_{DD}=IOV_{DD}=2.7 to 5.5V, DGND=SPGND=SPOGND=0V, Ta=-40 to +105°C, Load capacitance of output pin =15pF(max.)

Parameter	Symbol	Condition	Applicable pin	Min.	Typ.*1	Max.	Unit
"H" input voltage 1	V _{IH1}	—	LRCLK/BCLK/SAI_IN/ CSB/SCK/SI/ SAD0/SAD1/SAD2/ SDA/SCL/ XT/RESETB/TEST0	0.8×DV _{DD}	—	DV _{DD}	V
"H" input voltage 2	V _{IH2}	—	ERSI/EROFF	0.8×IOV _{DD}	—	IOV _{DD}	V
"L" input voltage 1	V _{IL1}	—	LRCLK/BCLK/SAI_IN/ CSB/SCK/SI/ SAD0/SAD1/SAD2/ SDA/SCL/ XT/RESETB/TEST0	0	—	0.2×DV _{DD}	V
"L" input voltage 2	V _{IL2}	—	EROFF/ERSI	0	—	0.2×IOV _{DD}	V
"H" output voltage 1	V _{OH1}	I _{OH} = -50μA	XTB	DV _{DD} -0.4	—	—	V
"H" output voltage 2	V _{OH2}	I _{OH} = -1mA	SAI_OUT/ SO/ CBUSYB/STATUS1/ STATUS2	DV _{DD} -0.4	—	—	V
"H" output voltage 3	V _{OH3}	I _{OH} = -1mA	ERCSB/ERSCK/ ERSO	IOV _{DD} -0.4	—	—	V
"L" output voltage 1	V _{OL1}	I _{OL} = 50μA	XTB	—	—	0.4	V
"L" output voltage 2	V _{OL2}	I _{OL} = 2mA	SAI_OUT/ SO/ CBUSYB/STATUS1/ STATUS2	—	—	0.4	V
"L" output voltage 3	V _{OL3}	I _{OL} = 2mA	ERCSB/ERSCK/ ERSO	—	—	0.4	V
"L" output voltage 4	V _{OL4}	I _{OL} = 3mA	SDA/SCL	—	—	0.4	V
Output leakage current 1	I _{OOH1}	VOH=DV _{DD} (in high-impedance state)	SDA/SCL/ SO	—	—	10	μA
	I _{OOL1}	VOL=DGND (in high-impedance state)		-10	—	—	μA
Output leakage current 2	I _{OOH2}	VOH=IOV _{DD} (in high-impedance state)	ERCSB/ERSCK/ ERSO	—	—	10	μA
	I _{OOL2}	VOL=DGND (in high-impedance state)		-10	—	—	μA
"H" input current 1	I _{IH1}	V _{IH} = DV _{DD}	XT	0.8	5.0	20	μA
"H" input current 2	I _{IH2}	V _{IH} = DV _{DD}	RESETB/ LRCLK/BCLK/SAI_IN/ CSB/SCK/SI/ SDA/SCL	—	—	10	μA
"H" input current 3	I _{IH3}	V _{IH} = DV _{DD}	TEST0	20	500	1000	μA
"H" input current 5	I _{IH5}	V _{IH} = IOV _{DD}	EROFF	20	500	1000	μA
"H" input current 6	I _{IH6}	V _{IH} = IOV _{DD}	ERSI	2	100	400	μA
"L" input current 1	I _{IL1}	V _{IL} = DGND	XT	-20	-5.0	-0.8	μA
"L" input current 2	I _{IL2}	V _{IL} = DGND	LRCLK/BCLK/SAI_IN/ CSB/SCK/SI/ SDA/SCL/EROFF/ TEST0	-10	—	—	μA
"L" input current 3	I _{IL3}	V _{IL} = DGND	RESETB	-400	-100	-2	μA

*1 Typ. : DV_{DD}=SPV_{DD}=SPOV_{DD}=IOV_{DD}=5.0V, DGND=SPGND=0 V, Ta=25°C

SPV_{DD}=SPOV_{DD}≥DV_{DD}=IOV_{DD}=2.7 to 5.5V, DGND=SPGND=SPOGND=0V, Ta=-40 to +105°C, Load capacitance of output pin =15pF(max.)

Parameter	Symbol	Condition	Applicable pin	Min.	Typ.*1	Max.	Unit
During playback Current consumption	I _{DDO}	f _{osc} =4.096MHz Fs=48kHz, f=1kHz, During HQADPCM playback SPP/SPM No output load	—	—	25*2	45*2	mA
Power-down Current consumption	I _{DDS}	Ta=-40 to +55°C	—	—	1*2	10.0*2	μA
		Ta=-40 to +105°C	—	—	1*2	30.0*2	μA

*1 Typ. : DV_{DD}=SPV_{DD}=SPOV_{DD}=IOV_{DD}=5.0V, DGND=SPGND=0 V, Ta=25°C

*2 Total values of the DV_{DD} pin, SPV_{DD} pin, SPOV_{DD} pin, and IOV_{DD} pin

● Analog Part Characteristics

SPV_{DD}=SPOV_{DD}≥DV_{DD}=IOV_{DD}=2.7 to 5.5V, DGND=SPGND=SPOGND=0V, Ta=-40 to +105°C, Load capacitance of output pin =15pF(max.)

Parameter	Symbol	Condition	Min.	Typ.	Max.	Unit
RC4MHz	F _{rc}	Ta=-40 to +70°C	3.89	4.096	4.31	MHz
		Ta=-40 to +105°C	3.68	4.096	4.51	MHz
AIN pin input resistance	R _{AIN}	Input gain 0dB	10	20	30	kΩ
AIN pin input voltage range	V _{AIN}	—	—	—	SPV _{DD} ×2/3	Vp-p
Line amplifier output resistance ¹	R _{LA1}	SPV _{DD} = 3.3 to 5.5V When 1/2SPV _{DD} ± 1 mA is applied	—	—	100	Ω
Line amplifier output resistance ²	R _{LA2}	SPV _{DD} = 2.7 to 3.6V When 1/2SPV _{DD} ± 1 mA is applied	—	—	300	Ω
Line amplifier output-load-resistance ^{*1}	R _{LA}	For SPGND	10	—	—	kΩ
Line amplifier Out put Voltage Range ^{*1}	V _{AO}	No output load	SPV _{DD} /6	—	SPV _{DD} ×5/6	V
SG pin output voltage	V _{SG}	—	0.95x SPV _{DD} /2	SPV _{DD} /2	1.05x SPV _{DD} /2	V
SG pin output resistance	R _{SG}	—	57	96	135	kΩ
SPP/SPM pins Output-Load Resistance	R _{LSP1}	—	6	8	—	Ω
To the SPP and SPM pins Short circuit detection	R _{OCDA}	Class AB speaker amplifier 4.5V≤SPV _{DD} ≤5.5V	0.1	—	6	Ω
Speaker amplifier output power ¹	P _{SPO1}	SPV _{DD} = SPOV _{DD} =5.0V, f=1kHz R _{SPO} =8Ω, THD=10%	0.8	1	—	W
Speaker amplifier output power ²	P _{SPO2}	SPV _{DD} = SPOV _{DD} =3.0V, f=1kHz R _{SPO} =8Ω, THD=10%	0.1	0.3	—	W
During no-signal SPM-SPP Output offset voltage	V _{OF}	AVOL=0dB 8 Ω load	-50	—	50	mV

*1 Applies to the SPP and LOUT pins when outputting LINE.

● AC characteristic

SPV_{DD}=SPOV_{DD}≥DV_{DD}=IOV_{DD}=2.7 to 5.5V, DGND=SPGND=SPOGND=0V, Ta=-40 to +105°C, Load capacitance of output pin =15pF(max.)

Parameter	Symbol	Condition	Min.	Typ.	Max.	Unit
Master clock duty cycle	f _{duty}	—	40	50	60	%
RESETB input pulse width	t _{RST}	—	10	—	—	μs
Reset noise rejection pulse width	t _{NRST}	RESETB pin	—	—	0.1	μs
Command input interval time	t _{INTC}	f _{osc} = 4.096MHz After input the first command at two-times command input mode	0	—	—	μs
Command input enable time	t _{cm}	f _{osc} = 4.096MHz During continuous playback at SLOOP input	—	—	10	ms
At PUP command input CBUSYB "L" level output time	t _{PUP}	4.096MHz external clock input	—	—	8	ms
At AMODE command input CBUSYB "L" level output time	t _{PUPA1}	4.096MHz external clock input POP="L" AEN0="L"→"H" AEN1 = "L" AVOL = -4dB is selected	35	37	39	ms
At AMODE command input CBUSYB "L" level output time	t _{PUPA2}	4.096MHz external clock input DAMP="L", POP="H" AEN1="L"→"H" (AEN0= "L": SPP-pin line amplifier output) (AEN0= "H": LOUT pin line amplifier output)	71	73	75	ms
At AMODE command input CBUSYB "L" level output time	t _{PUPA3}	4.096MHz external clock input DAMP="L", POP="L" AEN1="L"→"H" (AEN0= "L": SPP-pin line amplifier output) (AEN0= "H": LOUT pin line amplifier output)	31	33	35	ms
At PDWN command input CBUSYB "L" level output time	t _{PD}	f _{osc} = 4.096MHz	—	—	10	μs
At AMODE command input CBUSYB "L" level output time	t _{PDA1}	4.096MHz external clock input POP="L" AEN1="L", AEN0="H"→"L"	100	102	104	ms
At AMODE command input CBUSYB "L" level output time	t _{PDA2}	4.096MHz external clock input DAMP="L", POP="H" AEN1="H"→"L" (AEN0= "L": SPP-pin line amplifier output) (AEN0= "H": LOUT pin line amplifier output)	142	144	146	ms
At AMODE command input CBUSYB "L" level output time	t _{PDA3}	4.096MHz external clock input DAMP="L", POP="L" AEN1="H"→"L" (AEN0= "L": SPP-pin line amplifier output) (AEN0= "H": LOUT pin line amplifier output)	102	104	106	ms
CBUSYB "L" level output time 1 ^{*1}	t _{CB1}	f _{osc} = 4.096MHz	—	—	10	μs
CBUSYB "L" level output time 2 ^{*2}	t _{CB2}	f _{osc} = 4.096MHz	—	—	3	ms
CBUSYB "L" level output time 3 ^{*3}	t _{CB3}	FAD="L" at f _{osc} = 4.096MHz	—	—	200	μs
		FAD="H" at f _{osc} = 4.096MHz	—	—	10	ms

*1 Applies when inputting commands except the timings after PUP, PDWN, PLAY, or START command is input.

*2 Applies when inputting PLAY, START, MUON command.

*3 Applies when inputting STOP command.

● AC Characteristics (Clock Synchronous Serial Interface)

SPV_{DD}=SPOV_{DD}≥DV_{DD}=IOV_{DD}=2.7 to 5.5V, DGND=SPGND=SPOGND=0V, Ta=-40 to +105°C, Load capacitance of output pin =15pF(max.)

Parameter	Symbol	Condition	Min.	Typ.	Max.	Unit
CSB input enable time from EROFF falling edge	t _{EEROFF}	—	1000	—	—	ns
CSB hold time from EROFF rising edge	t _{EROFFH}	—	1000	—	—	ns
SCK setup time from CSB falling edge	t _{SCKS}	—	100	—	—	ns
SCK input enable time from CSB falling edge	t _{ESCK}	—	100	—	—	ns
SCK hold time from CSB rising edge	t _{CSH}	—	100	—	—	ns
Data floating time from CSB rising edge	t _{DOZ}	RL=3KΩ	—	—	100	ns
Data setup time from SCK	t _{DIS}	—	50	—	—	ns
Data hold time from SCK	t _{DIH}	—	50	—	—	ns
Data output delay time from SCK	t _{DOD}	—	—	—	90	ns
LSB data hold time from SCK	t _{DOH}	—	100	—	—	ns
SCK "H" level pulse width	t _{SCKH}	—	100	—	—	ns
SCK "L" level pulse width	t _{SCKL}	—	100	—	—	ns
CBUSYB output delay time from SCK	t _{DBSY}	—	—	—	90	ns

<When rewriting the flash memory using the clock synchronous serial interface>

SPV_{DD}=SPOV_{DD}≥DV_{DD}=IOV_{DD}=2.7 to 5.5V, DGND=SPGND=SPOGND=0V, Ta=-40 to +105°C, Load capacitance of output pin =15pF(max.)

Parameter	Symbol	Condition	Min.	Typ.	Max.	Unit
CSB input enable time from EROFF falling edge	t _{EEROFF}	—	1000	—	—	ns
CSB hold time from EROFF rising edge	t _{EROFFH}	—	1000	—	—	ns
SCK setup time from CSB falling edge	t _{SCKS}	—	125	—	—	ns
SCK input enable time from CSB falling edge	t _{ESCK}	—	125	—	—	ns
SCK hold time from CSB rising edge	t _{CSH}	—	125	—	—	ns
Data floating time from CSB rising edge	t _{DOZ}	RL=3KΩ	—	—	125	ns
Data setup time from SCK	t _{DIS}	—	50	—	—	ns
Data hold time from SCK	t _{DIH}	—	50	—	—	ns
Data output delay time from SCK	t _{DOD}	—	—	—	110	ns
LSB data hold time from SCK	t _{DOH}	—	100	—	—	ns
SCK "H" level pulse width	t _{SCKH}	—	125	—	—	ns
SCK "L" level pulse width	t _{SCKL}	—	125	—	—	ns

● AC Characteristics (I²C Interface)

SPV_{DD}=SPOV_{DD}≥DV_{DD}=IOV_{DD}=2.7 to 5.5V, DGND=SPGND=SPOGND=0V, Ta=-40 to +105°C, Load capacitance of output pin =15pF(max.)

Parameter	Symbol	Min	Max.	Unit
SCL clock frequency	t _{SCL}	0	400	kHz
SCL hold time (start/restart condition)	t _{HD;STA}	0.6	—	μs
SCL clock "L" level time	t _{LOW}	1.3	—	μs
SCL clock "H" level time	t _{HIGH}	0.6	—	μs
SCL setup time (restart condition)	t _{SU;STA}	0.6	—	μs
SDA hold time	t _{HD;DAT}	0	—	μs
SDA setup time	t _{SU;DAT}	0.1	—	μs
SDA setup time (stop condition)	t _{SU;STO}	0.6	—	μs
Bus free time	t _{BUF}	1.3	—	μs
Capacitive load on each bus line	C _b	—	400	pF

● AC Characteristics (SAI Interface (Slave))

SPV_{DD}=SPOV_{DD}≥DV_{DD}=IOV_{DD}=2.7 to 5.5V, DGND=SPGND=SPOGND=0V, Ta=-40 to +105°C, Load capacitance of output pin =15pF(max.)

Parameter	Symbol	Condition	Min.	Typ.	Max.	Unit
SAI_BCLK period	tC_BCLK	—	32fs	—	64fs	Hz
SAI_BCLK "H" period	tHW_BCLK	—	100	—	—	ns
SAI_BCLK "L" period	tLW_BCLK	—	100	—	—	ns
SAI_LRCLK hold time	tH_LRCLK	—	80	—	—	ns
SAI_LRCLK setup time	tSU_LRCLK	—	80	—	—	ns
SAI_SDOOUT delay time	tD_SDO *1	—	—	—	80	ns
SAI_SDIN setup time	tSU_SDI	—	20	—	—	ns
SAI_SDIN hold time	tH_SDI	—	20	—	—	ns

*1 tD_SDO is the time based on the slower change of SAI_BCLK or SAI_LRCLK.

● AC Characteristics (Flash Memory Interface)

SPV_{DD}=SPOV_{DD}≥DV_{DD}=IOV_{DD}=2.7 to 5.5V, DGND=SPGND=SPOGND=0V, Ta=-40 to +105°C, Load capacitance of output pin =15pF(max.)

Parameter	Symbol	Condition	Min.	Typ.	Max.	Unit
ERSCK enable time from ERCSB falling edge	t _{ECSS}	—	50	—	—	ns
ERSCK hold time from ERCSB rising edge	t _{ECSH}	—	50	—	—	ns
Data setup time from ERSCK rising edge	t _{EDIS}	—	10	—	—	ns
Data hold time from ERSCK rising edge	t _{EDIH}	—	10	—	—	ns
Data delay time from ERSCK falling edge	t _{EDOD}	—	—	—	5	ns
ERSCK frequency	t _{ESCKF}	—	1.228	16.384	17.20	MHz
ERSCK "H" level pulse width	t _{ESCKH}	—	26	—	—	ns
ERSCK "L" level pulse width	t _{ESCKL}	—	26	—	—	ns
ERCSB/ERSC/ERSO delay time from EROFF rising edge	t _{EFLH}	—	—	—	1	ms
ERCSB/ERSC/ERSO delay time from EROFF falling edge	t _{EFHL}	—	—	—	1	ms

■ Block diagram

The block diagram is shown below.

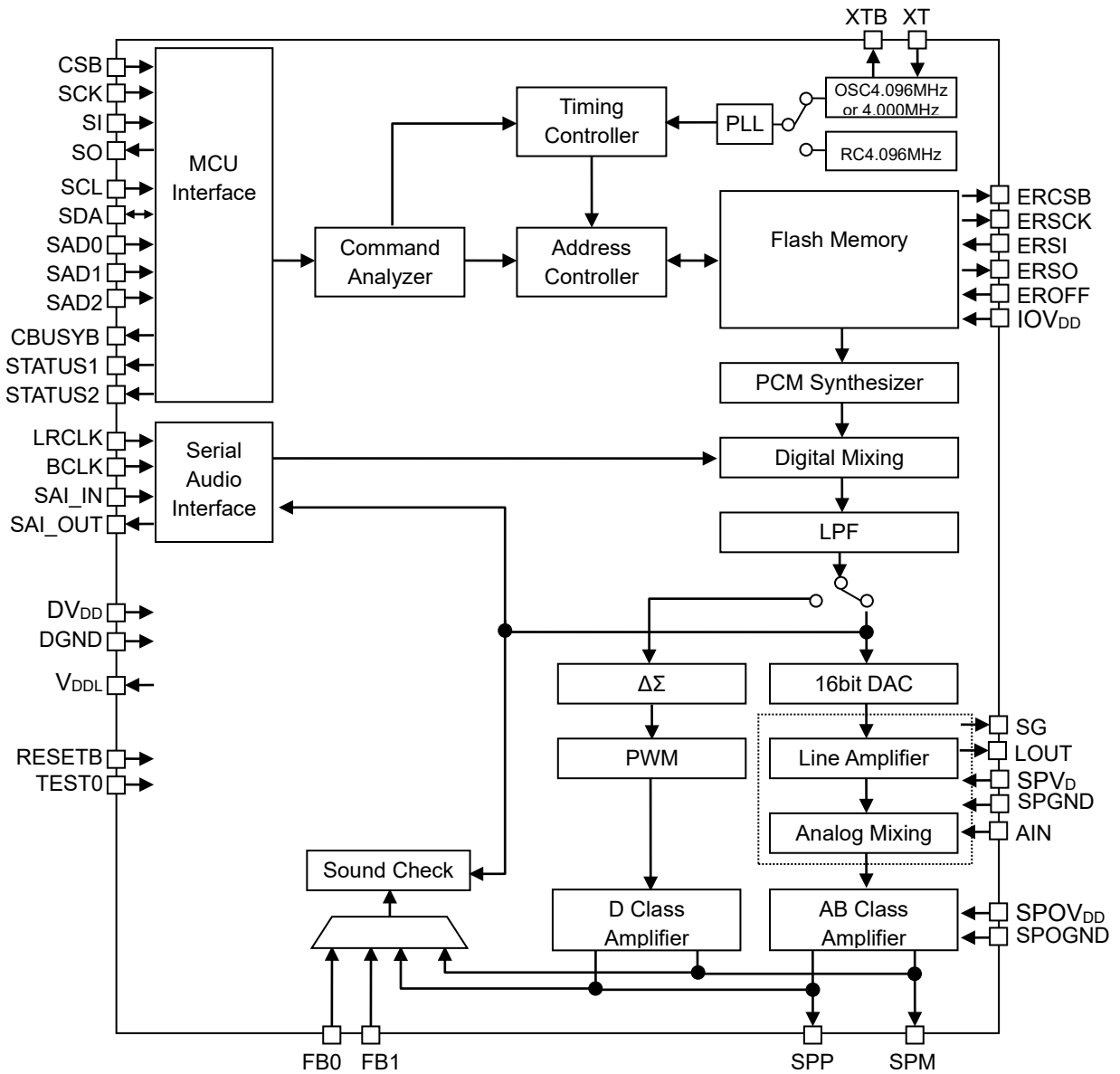

■ Function description

● Clock Synchronous Serial Interface

The CSB, SCK, SI, and SO pins are used to input various command data and to read the status.

For command and data inputting, after "L" level is input to the CSB pin, data is input to the SI pin in MSB first in synchronization with the input clock signal of the SCK pin. The SI pin data is loaded into the LSI in synchronization with the SCK pin clock, and the command data is determined by the SCK pin clock of the eighth pulse.

When reading, after "L" level is input to the CSB pin, it is output from the SO pin in synchronization with the input clock signal of the SCK pin.

The selection of the rising or falling edge of the SCK pin clock depends on the state of the SCK pin at the falling edge of the CSB pin.

When the SCK pin is "H" at the falling edge of the CSB pin, the SI pin data is loaded into the LSI on the rising edge of the SCK pin clock, and the status signal is output from the SO pin on the falling edge of the SCK pin clock.

When the SCK pin is "L" at the falling edge of the CSB pin, the SI pin data is loaded into the LSI on the falling edge of the SCK pin clock, and the status signal is output from the SO pin on the rising edge of the SCK pin clock.

When the CSB pin is fixed to "L" level, the SI pin data is loaded into the LSI on the rising edge of the SCK pin clock, and the status signal is output from the SO pin at the falling edge of the SCK pin clock.

However, if unexpected pulses are input to the SCK pin due to noise, etc., the count of the number of SCK pin clocks may be shifted, and normal command input may not be performed.

The serial interface can be returned to the initial state by setting the CSB pin to "H" level.

When the CSB pin is "H" level, the SO pin becomes a high impedance state.

Accessing with I²C slave interface at the same time is prohibited.

Command data input timing: SCK rising edge operation
(When the SCK is "H" at the falling edge of the CSB)

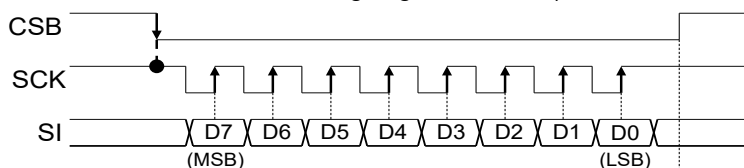

Command data input timing: SCK falling edge operation
(When the SCK is "L" at the falling edge of the CSB)

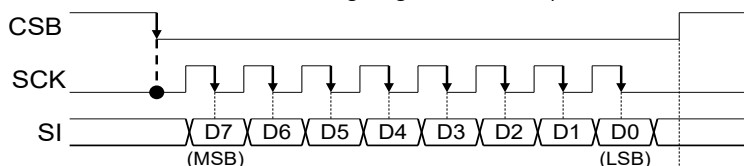

Command data output timing: SCK falling edge operation
(When the SCK is "H" at the falling edge of the CSB)

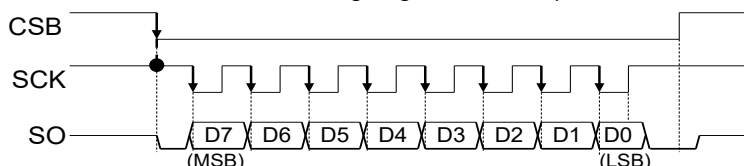

Command data output timing: SCK rising edge operation
(When the SCK is "L" at the falling edge of the CSB)

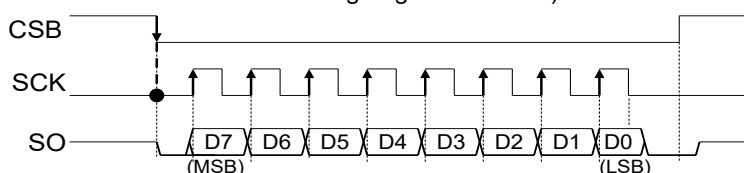

● I²C Interface (Slave)

This serial interface conforms to the I²C bus specifications. It supports Fast modes and can transmit and receive data at 400kbit/s. The SCL and SDA pins are used to input various command data and to read the status. The slave addresses are set by the SAD0 to 2 pins.

When I²C is used, be sure to connect a pull-up resistor between SCL and SDA pins and DV_{DD} pin.

In the communication flow between the master and this device (slave) on the I²C bus, after the start condition is set, the slave address (upper 3 bits of the slave address are set by the SAD0 to 2 pins) is entered in the first 7 bits, the data direction is determined in the 8th bit (when the 8th bit is "0", data is written from the master, and data is read from the master when "1") and communication is performed in byte units thereafter. At this time, acknowledgment is required for each byte.

Accessing with clock synchronous serial interface at the same time is prohibited.

The I²C communication flow/timing chart is shown below.

◆ Command flow when writing data (1-byte command)

- Start condition
- Slave address +W(0)
- Write data (ex. Command 1st byte)
- Stop condition

- Timing chart when writing data. (1 byte command)

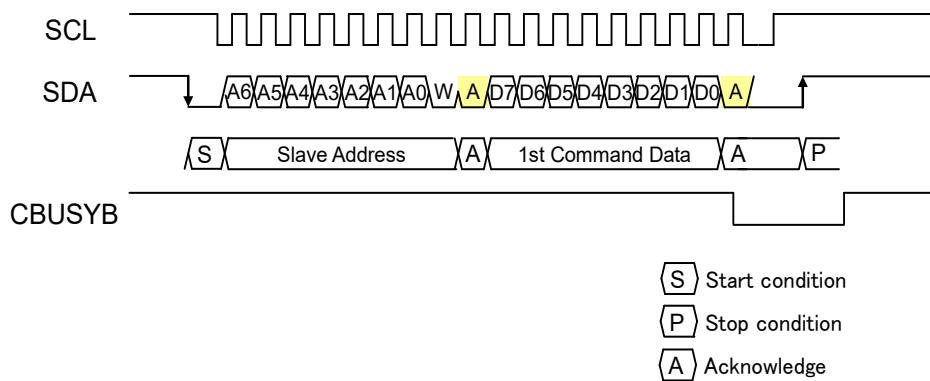

◆ Command flow when writing data (2-byte command)

- Start condition
- Slave address +W(0)
- Write data (ex. Command 1st byte)
- Write data (ex. Command 2nd byte)
- Stop condition

- Timing chart when writing data. (2 byte command)

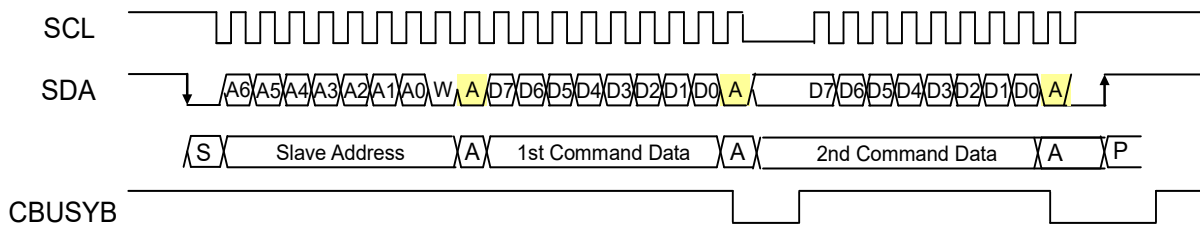

◆ Command flow when writing data (3-byte command)

- Start condition
- Slave address +W(0)
- Write data (ex. Command 1st byte)
- Write data (ex. Command 2nd byte)
- Write data (ex. Command 3rd byte)
- Stop condition

- Timing chart when writing data. (3 byte command)

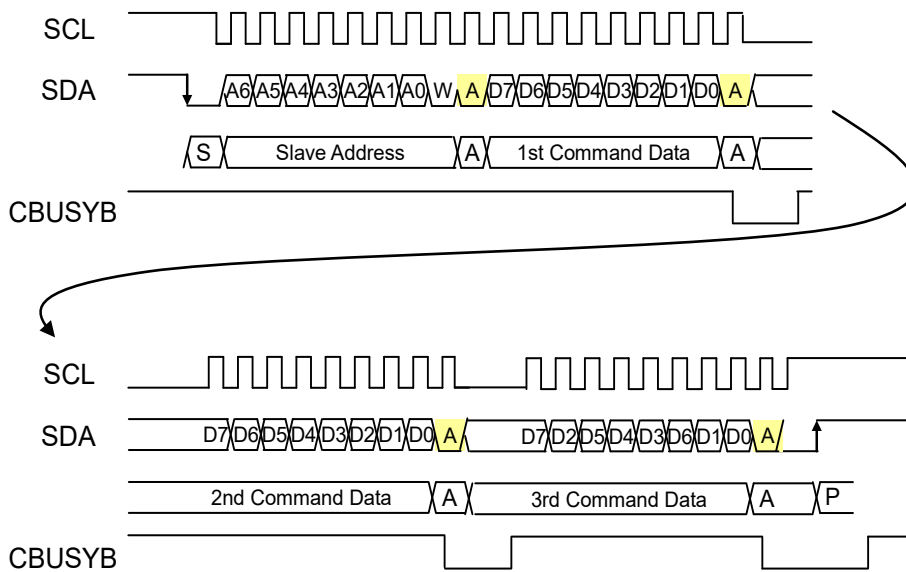

◆ Command flow when reading data

Start condition
 Slave address +W(0)
 RDSTAT Command
 Stop condition

Start condition
 Slave address + R(1)
 Read data (ex. Status read)
 Stop condition

- Timing chart when reading data.

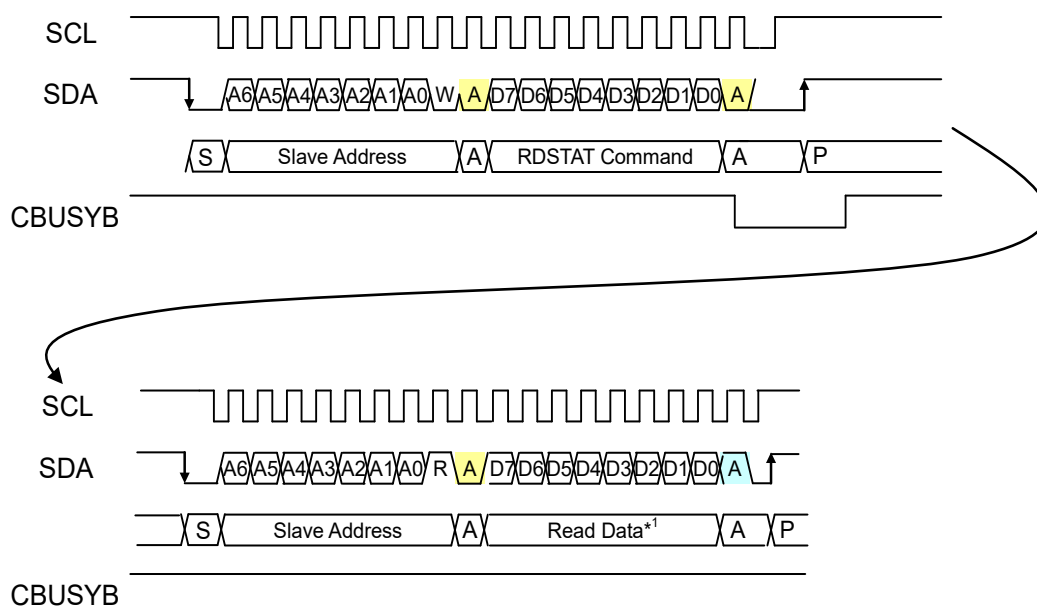

*1 When the two-time input mode, the error state reading is 2 bytes

The data read flow is used when data is read by RDSTAT/RDERR/RDVER commands. The data to be read is updated by inputting RDSTAT/RDERR/RDVER command. Be sure to enter the RDSTAT/RDERR/RDVER command before reading the internal status.

The slave address can be set as follows using the SAD2 to SAD0 pin.

SAD2	SAD1	SAD0	Lower 4 bits	Slave address
0	0	0	0101	000_0101
0	0	1	0101	001_0101
0	1	0	0101	010_0101
0	1	1	0101	011_0101
1	0	0	0101	100_0101
1	0	1	0101	101_0101
1	1	0	0101	110_0101
1	1	1	0101	111_0101

● SAI (Serial Audio Interface)

SAI transfers digital sound data serially.

The sound data input from the SAI_IN pin can be played using the speaker amplifier or LINE amplifier.

Furthermore, not only can it be mixed with the sound data in the flash memory and played back by the speaker amplifier or LINE amplifier, but it can also be output from SAI_OUT pin.

Various serial data formats are supported by a combination of command settings.

A WSLI, DLYI and MSBI are used to represent the supported formats.

For WSLI, DLYI and MSBI, refer to the "SAIRCON command".

When using SAI, set the analog power-up state with the AMODE command.

<DLYI="0", ISSCKI="0" / DLYO="0", ISSCKO="0", MSBI="0">

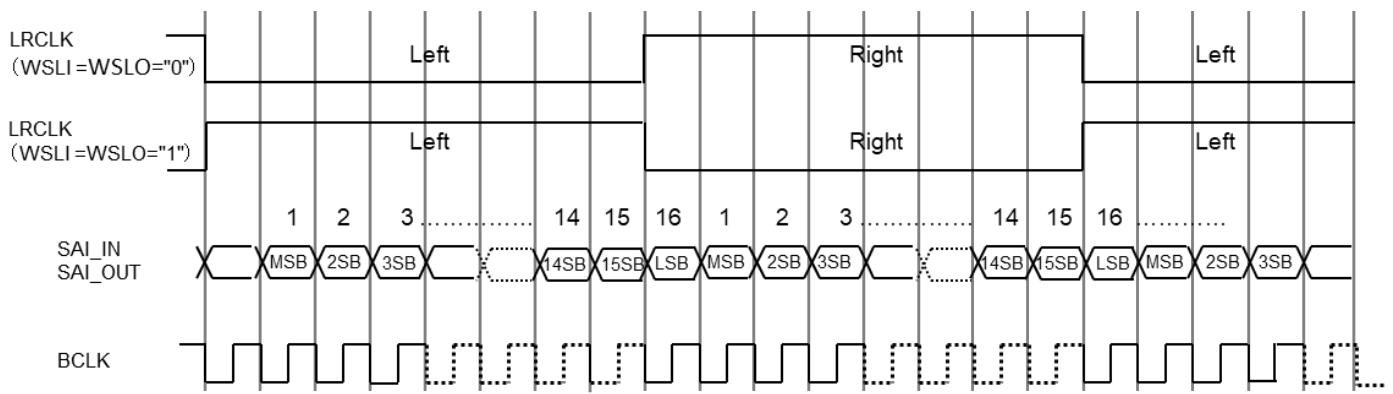

<DLYI="0", ISSCKI="1" / DLYO="0", ISSCKO="1", MSBI="0">

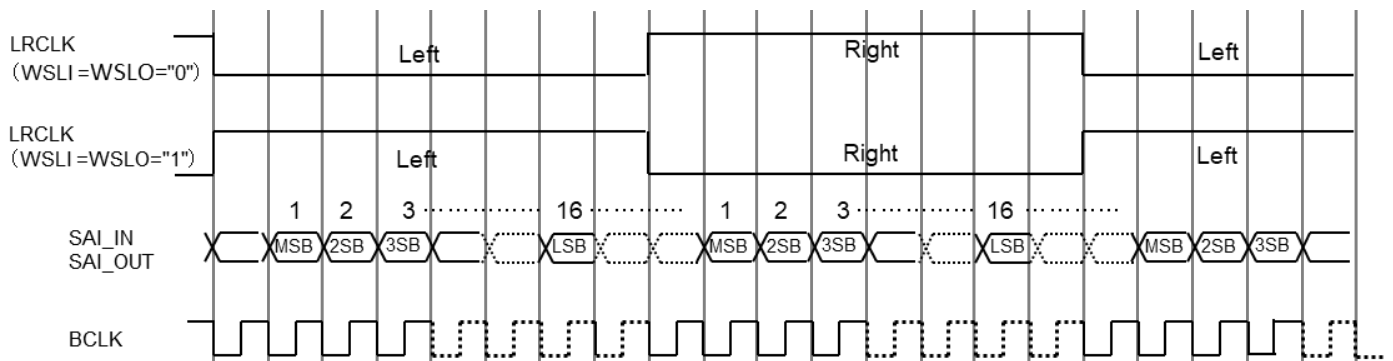

<DLYI="1", ISSCKI="1" / DLYO="1", ISSCKO="1", MSBI="0">

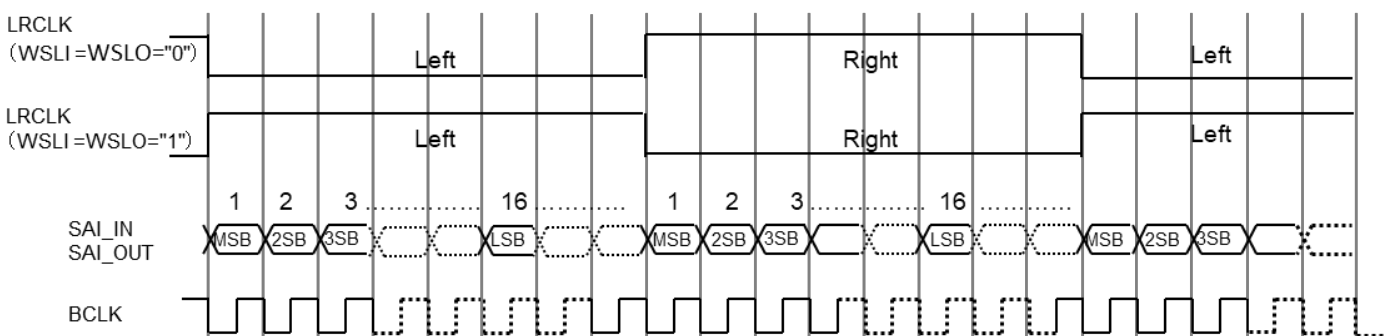

<DLYI="0", ISSCKI="0" / DLYO="0", ISSCKO="0", MSBI="1">

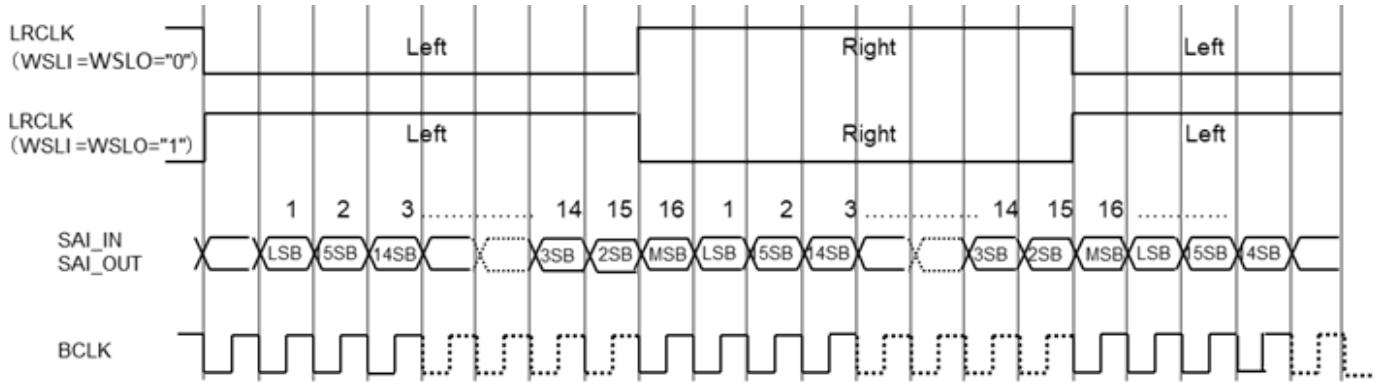

● Volume Settings (Differences Between AVOL and CVOL and PAN)

The volume can be set with four commands CVOL, PAN, AVOL and AMODE.

The CVOL can set the volume of each channel, the PAN can set the volume of each channel (Lch/Rch) output to the SAI_OUT pin, the AVOL can set the volume after channel mixing, and the AMODE can set the input gain to the amplifier. By using the fade function with FADE command, the volume can be adjusted stepwise when the volume is changed with CVOL and PAN.

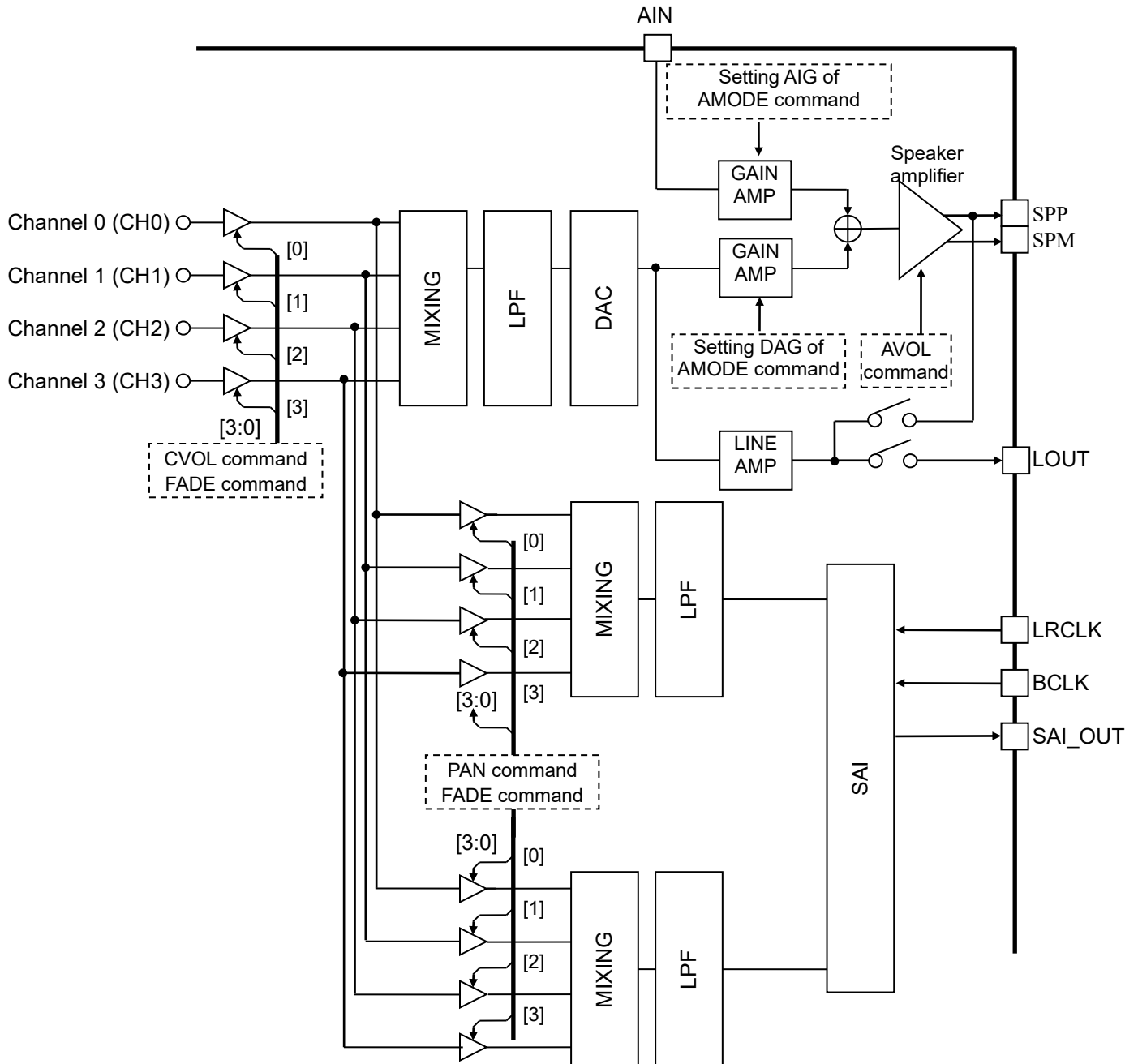

● Speech synthesis algorithm

This LSI contains five algorithm types to match the characteristic of playback sound: 4-bit ADPCM2 algorithm, HQ-ADPCM algorithm, 8-bit non-linear PCM algorithm, 8-bit straight PCM algorithm, and 16-bit straight PCM algorithm. Key feature of each algorithm is described in the table below.

Speech synthesis algorithm	Compression rate *1	Feature
HQ- ADPCM	1/5	4bit ADPCM algorithm is improved. Adopting variable bit length enables high sound quality and high data compression. Suitable for sound effects with sharp changes in waveforms or for pulsed waveforms.
4-bit ADPCM2	1/4	LAPIS original 4bit ADPCM algorithm is improved. Better followability to the waveform improves the sound quality. Suitable for human voices, animal crying, and natural sounds.
8-bit non-linear PCM	1/2	This algorithm enables playing back a sound with 10-bit equivalent quality in the center of the waveform. Suitable for low-amplitude sounds that are easily distorted.
8-bit straight PCM	1/2	This algorithm has excellent followability to the waveform in all sound areas. Suitable for sound effects with sharp changes in waveforms or for pulsed waveforms.
16-bit straight PCM	1	This algorithm has excellent followability to the waveform in all sound areas. Suitable for sound effects with sharp changes in waveforms or for pulsed waveforms.

*1: When using the same sampling frequency.

● Memory Allocation and Creating Sound Data

The serial flash memory is partitioned into four data areas: sound (i.e., phrase) control area, test area, sound area, and edit ROM area.

The sound control area manages the sound data in the ROM. It contains data for controlling the start/stop addresses of sound data for 4,096 phrases, use/non-use of the edit ROM function and so on.

The test area contains data for testing.

The sound area contains actual waveform data.

The edit ROM area contains data for effective use of sound data. For the details, refer to the section of "Edit ROM Function".

The edit ROM area is not available if the edit ROM is not used.

The Sound data is created using a dedicated tool (Speech LSI Utility).

Configuration of Serial Flash Memory Data (4Mbit)

0x00000	Test area
0x0007F	
0x00080	Sound control area (*) (The number of phrases can be set with the dedicated tools.)
0x0207F	
0x02080	Sound area

0x7FFFF	
	Edit ROM area Depends on creation of sound data

(*) When the number of phrases is set to 1024
The number of phrases can be set from 1024 to 4096 in 1024 units using the dedicated tools.

● Playback time and memory capacity

The playback time depends on the number of phrases, memory capacity, sampling frequency, and playback algorithm. The relationship is shown below. However, this is the playback time when the edit ROM function is not used.

$$\text{Playback Time} = \frac{1.024 \times (\text{Memory Capacity (kbit)} - (0.0625 \times \text{Number of Phrases}) - 0.625)}{\text{Sampling frequency (kHz)} \times \text{bit length}} \quad (\text{sec})$$

When the number of phrases is 1024, the sampling frequency is 16kHz, and the HQ-ADPCM algorithm is selected, the playback time will be approximately 81 seconds.

$$\text{Playback Time} = \frac{1.024 \times (4096(\text{kbit}) - (0.0625 \times 1024) - 0.625)}{16 (\text{kHz}) \times 3.2 (\text{bit}) (\text{average})} \doteq 81 (\text{sec})$$

● Edit ROM Function

With the edit ROM function, multiple phrases can be played in succession. The following functions can be configured using the edit ROM function:

- Continuous playback: There is no limit to the continuous playback count that can be specified. It depends on the memory capacity only.
- Silence insertion: 20 to 1024 ms

Using the edit ROM function enables an effective use of the flash memory capacity.

Below is an example of the ROM configuration in the case of using the edit ROM function.

Examples of phrases using the edit ROM function

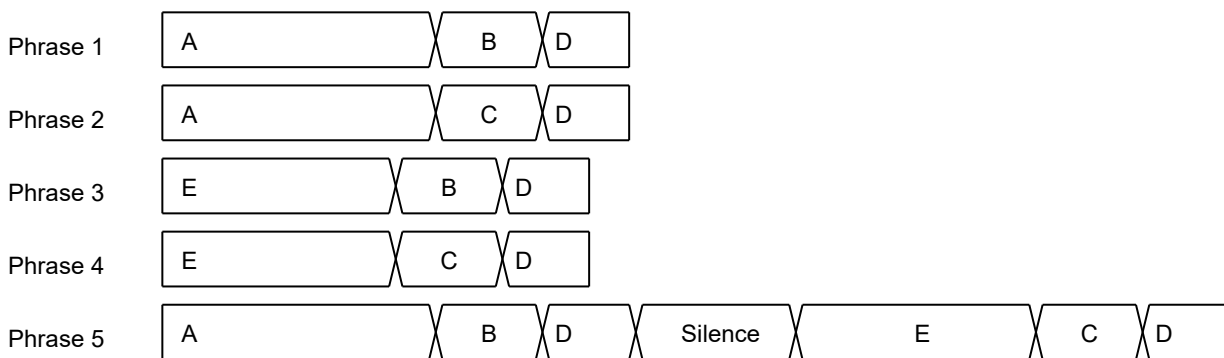

Example of sound data where the contents above are stored in ROM

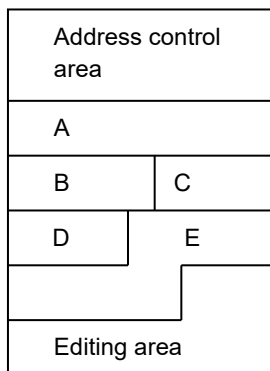

● Mixing function

Up to 4 channels mixing playback is possible at the same time. Commands with channel designation can set channels independently.

◆ Restrictions when using Serial Audio Interface(SAI).

When the serial audio interface (SAI) is not used, there is no limitation to the maximum number of mixing in each speech synthesis algorithm.

<When the serial audio interface (SAI) is not used>

Sampling frequency (kHz)	Speech synthesis algorithm	Maximum mixing number	Playable channels (○: Playable/x: Not playable)			
			CH0	CH1	CH2	CH3
All sampling frequency	4-bit ADPCM2	4	○	○	○	○
	HQ-ADPCM					
	8-bit non-linear PCM					
	8-bit straight PCM					
	16-bit straight PCM					

When the serial audio interface (SAI) is used, there are some limitations to the maximum number of mixing and playable channels depending on the sampling frequency.

<When the serial audio interface (SAI) is used>

Sampling frequency (kHz)	Speech synthesis algorithm	Maximum mixing number	Playable channels (○: Playable/x: Not playable)			
			CH0	CH1	CH2	CH3
12.0/24.0/48.0 11.025/22.05/44.1	4-bit ADPCM2	3*2	○	○	○	×
	HQ-ADPCM		○	○	○	×
	8-bit non-linear PCM		○	○	○	×
	8-bit straight PCM		○	○	○	×
	16-bit straight PCM	○	○	○	×	
	SAI*1	2	○	○	○	×
8.0/16.0/32.0	4-bit ADPCM2	4*3	○	○	○	○
	HQ-ADPCM		×	×	×	×
	8-bit non-linear PCM		○	○	○	○
	8-bit straight PCM		○	○	○	○
	16-bit straight PCM	○	○	○	○	
	SAI*1	2	○	○	○	○

*1 When both Lch and Rch are used by SAI, two channels are used by SAI. When only one of Lch or Rch is used, one channel is used for SAI.

*2 When two channels are used in SAI, one channel can be used, and when one channel is used in SAI, two channels can be used.

*3 When two channels are used in SAI, two channels can be used, and when one channel is used in SAI, three channels can be used.

When mixing at the sampling frequencies of 8.0/16.0/32.0kHz with using Serial Audio Interface(SAI), HQ-ADPCM cannot be used.

◆ Waveform clamp precautions for mixing

When mixing, the clamp may be generated as shown in the figure below due to the calculation of the synthesis. If the clamp is known to be generated in advance, adjust the volume of each channel by CVOL and PAN commands.

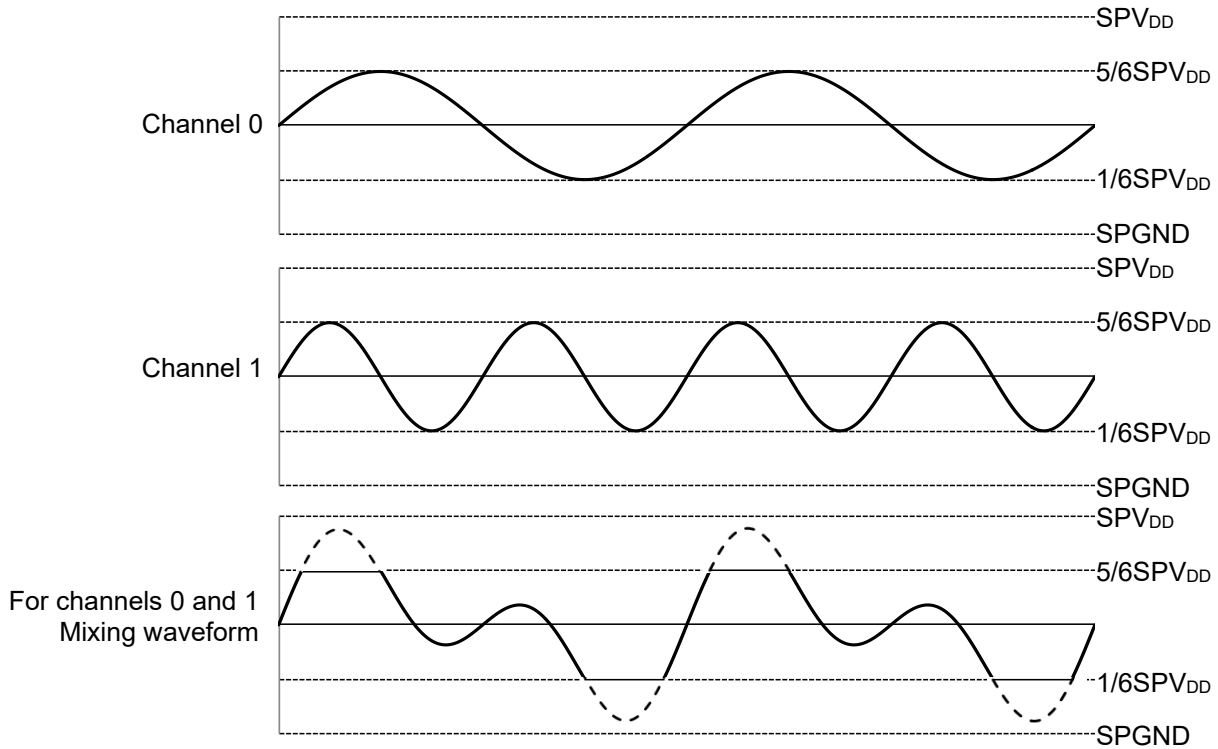

If the result of mixing channels 0 and 1 exceeds from the $1/6SPV_{DD}$ to $5/6SPV_{DD}$ level (as indicated by the broken line), the sound quality may be reduced by clamping. Waveforms when AVOL is set to 0.0dB.

◆ Different sampling frequency mixing algorithm

It is not possible to perform channel mixing by a different sampling frequency group.

Note that when channel synthesis is performed on a sampling frequency group other than the selected sampling frequency group, playback will be faster or slower. When either LEN or REN is set to "1" by the SAI (serial audio interface) SAICH command, the frequency is fixed to the frequency group of the SAI selected by the SAICON command.

The following table lists the frequency group that can be used when mixing different sampling frequency groups.

6.4kHz, 12.8kHz, 25.6kHz	... (Group 1)
8.0kHz, 16.0kHz, 32.0kHz	... (Group 2)
11.025kHz, 22.05kHz, 44.1kHz	... (Group 3)
12.0kHz, 24.0kHz, 48.0kHz	... (Group 4)
10.7kHz, 21.3kHz	... (Group 5)

The figure below shows the operation image when a sampling frequency group with different sampling frequency group is played back.

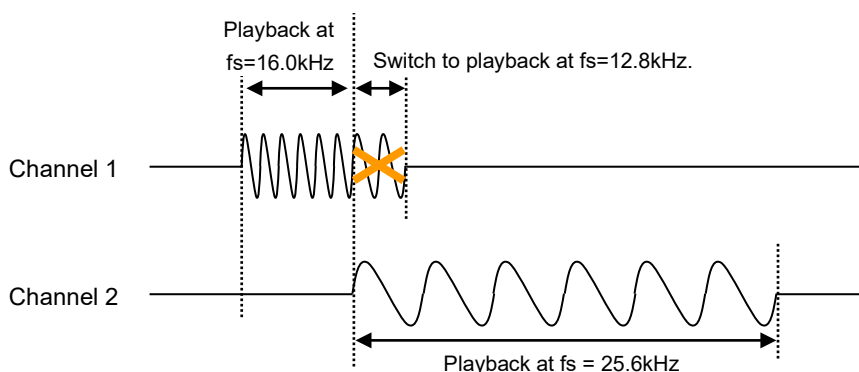

Figure 1) Case where a phrase is played at a sampling frequency belonging to a different sampling frequency group during playback on channels 1 and 2

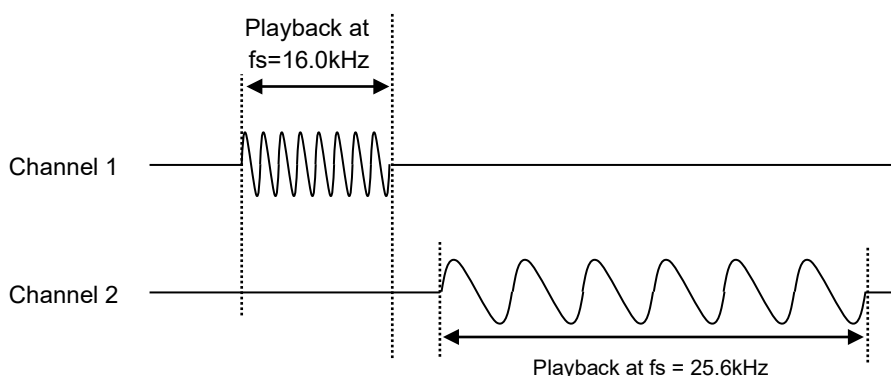

Figure 2) Case where a phrase is played at a sampling frequency belonging to a different sampling frequency group after playback is finished at the other channel

● Misoperation detection and failure detection functions

Misoperation detection and failure detection functions can be set with SAFE command. The error detection status can be read by the RDERR command, and the error bit indicating the error detection status can be cleared by the ERRCL command. In addition, OUTSTAT command can be used to send whether an error is detected or not to the STATUS1 pin or STATUS2 pin. For SAFE, RDERR, ERRCL and OUTSTAT commands, refer to the "Command" section.

Misoperation detection and failure detection are shown below.

- Command error detection
- Speaker disconnection detection
- LSI temperature error detection
- SPP pin and SPM pin short detection
- Flash memory error detection
- Watchdog timer overflow detection
- RST counter overflow detection
- Detects the stop of clock input from a crystal resonator or ceramic resonator.
- Detects disconnection/short-circuit of the BCLK.
- Detects disconnection/short-circuit of the LRCLK.
- Detects disconnection/short-circuit of the SAI_IN.
- Mixing number error detection
- Playback sound error detection^{*1}

*1 For details on the playback sound error detection function, refer to How to use the playback sound error detection function.

◆ Command error detection

This LSI detects two command errors: phrase number error and command error. Use the WCMEN bit of the SAFE command to set command error detection.

① Phrase number error.

Set the number of phrases (1024, 2048, 3072 or 4096) to use when creating sound data in the Speech LSI Utility. If you specify a phrase that exceeds the number of phrases specified by the Speech LSI Utility with the PLAY2 or FADR2 command, an error in the command is detected and the error bit (WCMERR) is set to "1".

② Command error.

This LSI has a function to input various commands and data two-times to prevent malfunction due to noise at the serial interface pin. The setting of the two-times input mode is made at power-up. Refer to the "PUP command" for the setting method.

In the two-times input mode, the command data is input two-times in succession, and it is valid only when the input data matches. If a mismatch occurs during the second data input after the first data input, an error in the command is detected and the error bit (WCMERR) is set to "1", and the command entered is ignored.

Error bit (WCMERR) can be read with RDERR command. Also, error bit (WCMERR) can be cleared by ERRCL command.

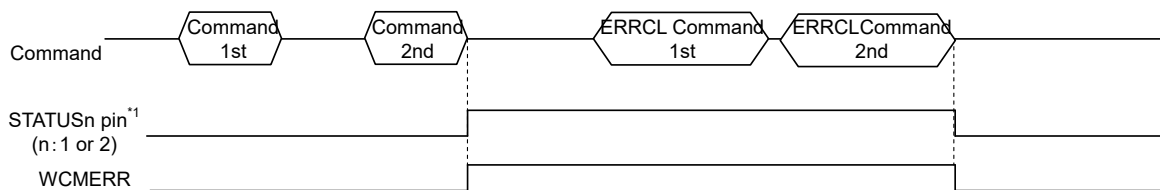

*1 Misoperation detection and failure detection outputs are selected by OUTSTAT command.

◆ Speaker disconnection detection

Set the speaker disconnection detection with the DCDEN bit of the SAFE command.

The speaker connection status of the SPP and SPM pins is checked when the analog power-up is activated in speaker amplifier output mode by AMODE command. When the disconnection of the speaker is detected, the error bit (DCDERR) is set to "1".

Error bit (DCDERR) can be read with RDERR command. Also, error bit (DCDERR) can be cleared by ERRCL command.

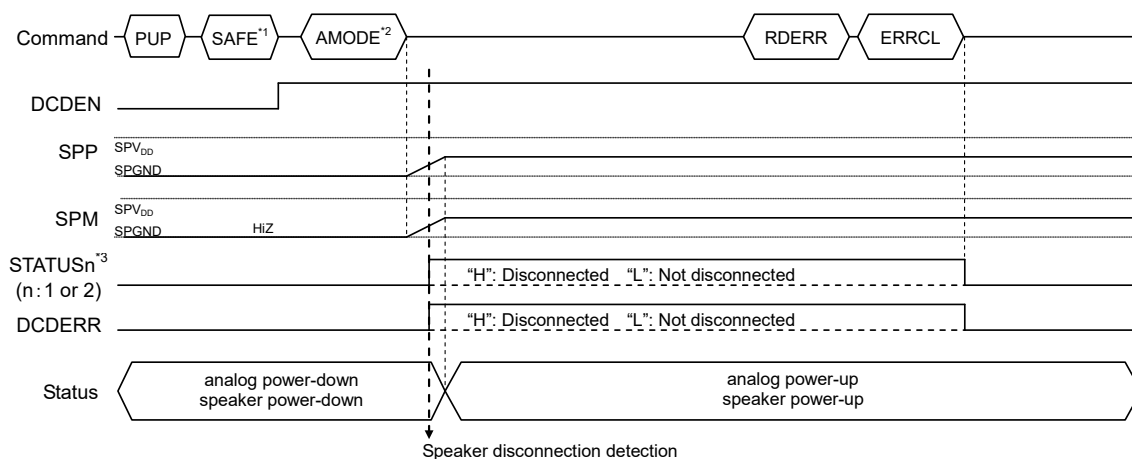

*1 Set DCDEN = "1"

*2 Analog power-up in speaker amplifier output mode

*3 Misoperation detection and failure detection outputs are selected by OUTSTAT command.

◆ LSI temperature error detection

Set the LSI temperature error detection with the TSDEN bit of the SAFE command.

When the TSDEN bit is set to "1" by the SAFE command, LSI temperature error detection starts. When the TSDEN bit is set to "0", LSI temperature error detection ends.

When the LSI becomes 130°C or more, the error bit (TSDERR) becomes "1".

Error bit (TSDERR) can be read with RDERR command. Also, error bit (TSDERR) can be cleared by ERRCL command.

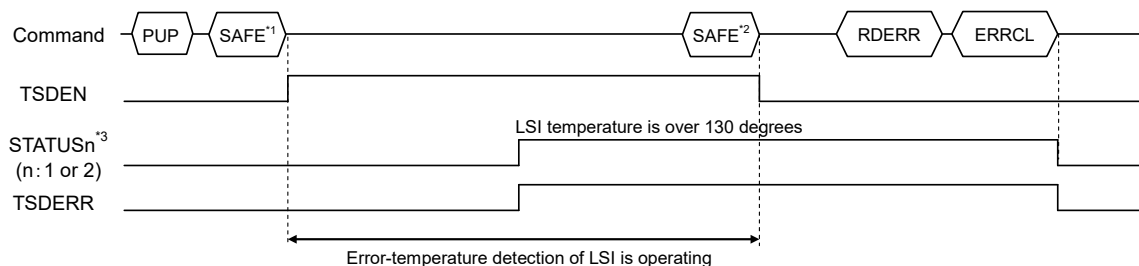

*1 Set TSDEN = "1"

*2 Set TSDEN = "0"

*3 Misoperation detection and failure detection outputs are selected by OUTSTAT command.

◆ SPP pin and SPM pin short detection

Set the SPP pin and SPM pin short detection with the SPDEN bit of the SAFE command.

Detects short circuit between SPP pin and SPM pin, or SPP pin and GND (ground fault), or SPM pin and GND (ground fault). Can be used when $SPV_{DD} \geq 4.5V$. Operation is started by analog power-up in the speaker amplifier output mode by the AMODE command, and operation is terminated by power-down in the speaker amplifier output mode by the AMODE command.

After inputting SAFE command, start the analog power-up operation by AMODE command within 10ms.

When a short-circuit is detected, the error bit (SPDERR) is set to "1". When using a class D amplifier with the DAMP bit of AMODE command set to "1", if the PWM output is fixed to "H" level for 62.5 μ s or longer, the error bit (SPDERR) is set to "1". At the same time, the speaker amplifier output pin (SPP/SPM) is forcibly turned off. Read the error bit (SPDERR) with the RDERR command, end playback, and perform analog power-down with the AMODE command. Then, use ERRCL command to clear the error bit (SPDERR).

To restart playback, use the AMODE command to analog power-up the speaker amplifier output mode and enter the PLAY command. However, if shorting to ground continues, the error bit (SPDERR) is set to "1" and the speaker amplifier output pin (SPP/SPM) is forcibly turned off simultaneously.

Short detection prevents damage to LSI. However, the detection circuit is effective in preventing damage due to unexpected accidents. It does not support continuous short operation or transient use.

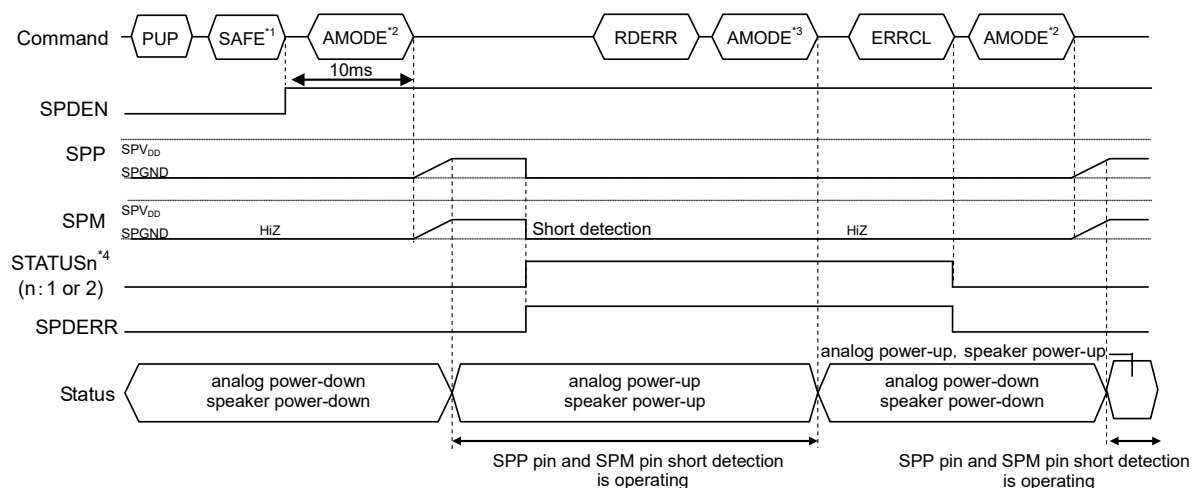

*1 Set 1 SPDEN = "1"

*2 Analog power-up in speaker amplifier output mode

*3 Analog power-down in speaker amplifier output mode

*4 Misoperation detection and failure detection outputs are selected by OUTSTAT command.

◆ Flash memory error detection

Set the Flash memory error detection with the ROMEN bit of the SAFE command. It is possible to detect two kinds of errors.

① Flash memory read data error

When an error is detected in the read data from the flash memory, the error bit (ROMERR) is set to "1". At the same time, playback of the corresponding channel is stopped.

If the error bit (ROMERR) is set to "1" after the PUP command and before the PLAY command or START command starts playback, this LSI may have error at the time of start. In such cases, initialize this LSI by moving the LSI to the power-down mode by resetting the LSI by the RESETB pin or by using PDWN command.

② Access outside the flash memory address range

If the flash memory is accessed outside the flash memory address range, an error is detected and the error bit (ROMERR) is set to "1".

At the same time, playback of the corresponding channel is stopped.

Error bit (ROMERR) can be read with RDERR command. Error bit (ROMERR) can be cleared by ERRCL command.

◆ Watchdog timer overflow detection

A communication error between the HOST MCU and this LSI (disconnection or short-circuit of the MCU command interface, etc.) can be detected.

Set the watchdog timer overflow detection with WDTEN bit of the SAFE command.

When the detection operation is started, the detection does not stop even if the WDTEN bit is set to "0".

After the detection operation starts, clear the WDT counter with the WDTCL command before the WDT counter overflows.

When the WDT counter overflows (for the first time), the error bit (WDTERR) is set to "1".

Error bit (WDTERR) can be read with RDERR command. In addition, the error bit (WDTERR) can be cleared by the ERRCL command after the WDTCL command.

The count time of the WDT counter is 2s the initial value. The counting time can be set to 125ms, 500ms, 2s, 4s. In addition, it is possible to shift to the command wait state after power-up by the second overflow of the WDT counter.

The count time and the second overflow operation can be set with the dedicated tools (Speech LSI Utility).

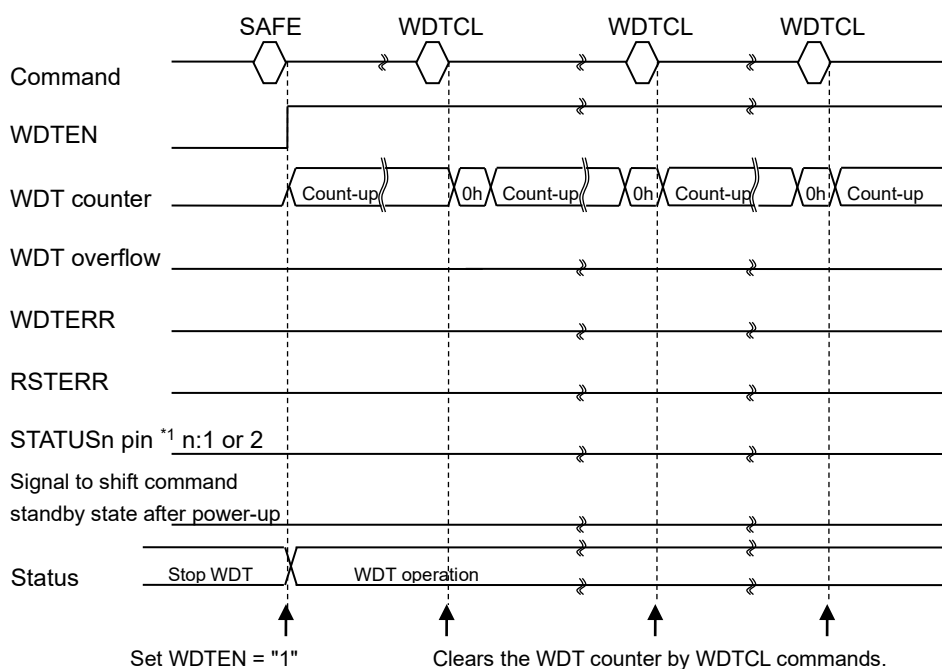

*1 Misoperation detection and failure detection outputs are selected by OUTSTAT command.

Recommended Operation Flow of Watchdog Timer

The operation when no WDTCL command is entered is as follows.

<When "Transition to the command standby state after power-up" is selected by the second overflow of the WDT counter>

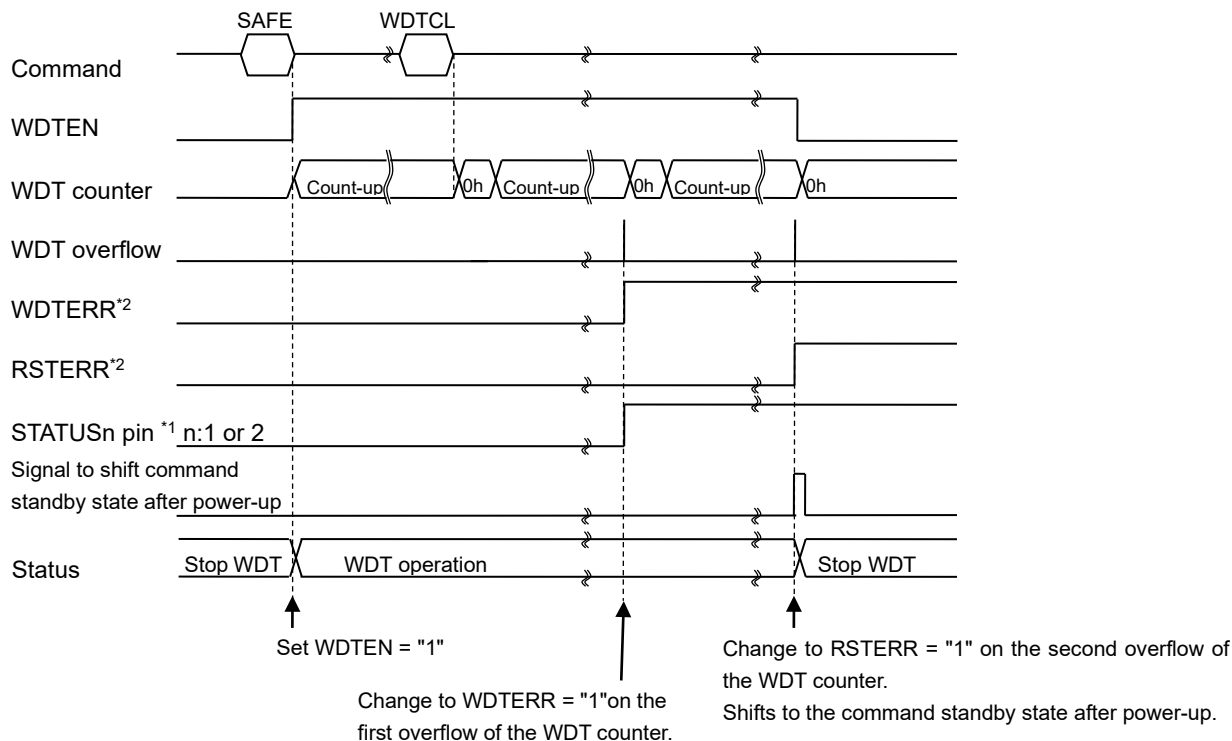

*1 Misoperation detection and failure detection outputs are selected by OUTSTAT command.

*2 Even if transferring to the command standby state after power-up by the second overflow of the WDT counter, the states of WDTERR bit and RSTERR bit remain. The state configured by OUTSTAT command also remains.

<When "Transition to the command standby state after power-up" is not selected by the second overflow of the WDT counter>

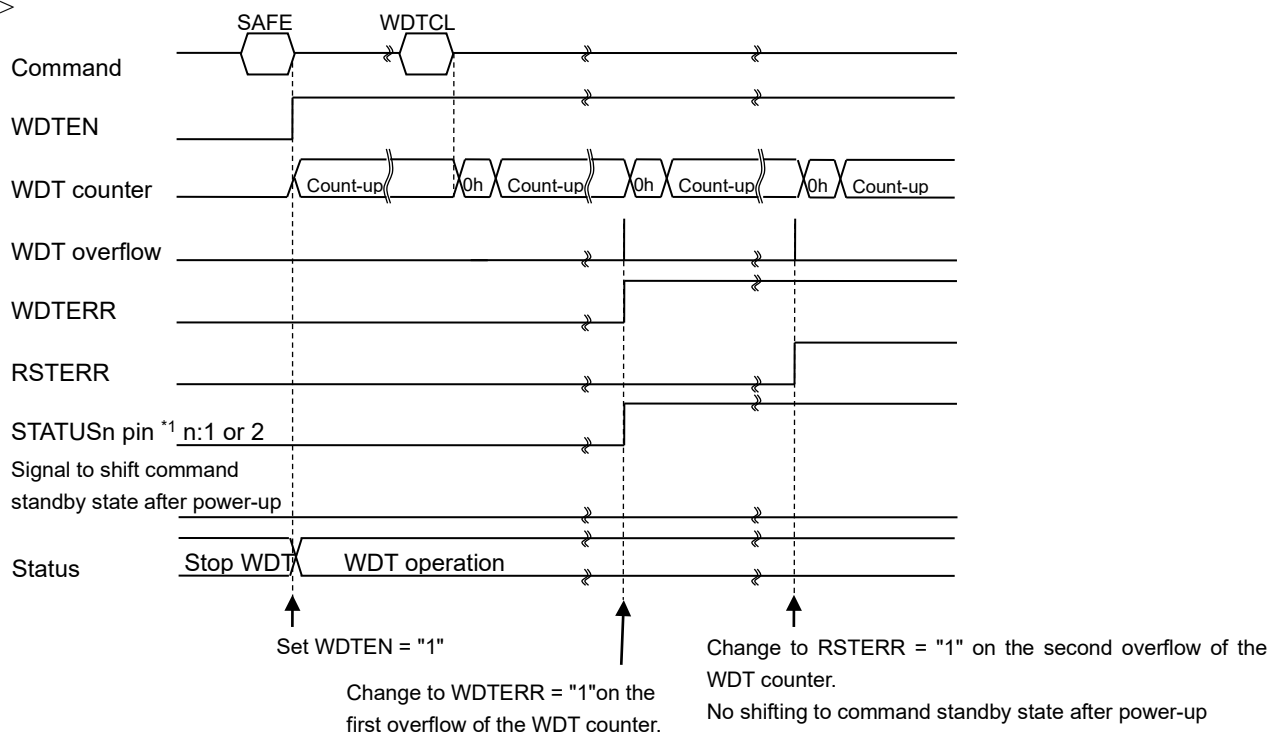

*1 Misoperation detection and failure detection outputs are selected by OUTSTAT command.

◆ RST counter overflow detection

By using the RST counter overflow detection, it is possible to shift the LSI to the command standby state after power-up after misoperation detection and failure detection occurs.

When the overflow detection of RST counter is set by RSTEN bit of SAFE command, the detection operation will start.

When the detection operation is started, the detection does not stop even if the RSTEN bit is set to "0".

The RST counter starts counting up after misoperation detection and failure detection occurs.

If the RST counter is cleared with the ERRCL command before it overflows, it stops until the next error occurs.

When the RST counter overflows, the error bit (RSTERR) is set to "1".

Error bit (RSTERR) can be read with RDERR command. Also, error bit (RSTERR) can be cleared by ERRCL command.

The count time of the RST-counter is 2s, the initial-value. The counting time can be set to 125ms, 500ms, 2s, or 4s.

Set the counting time and overflow operation (shift to the command standby state after power-up) with the dedicated tools (Speech LSI Utility).

The operation when RSTEN is set to "1" is as follows.

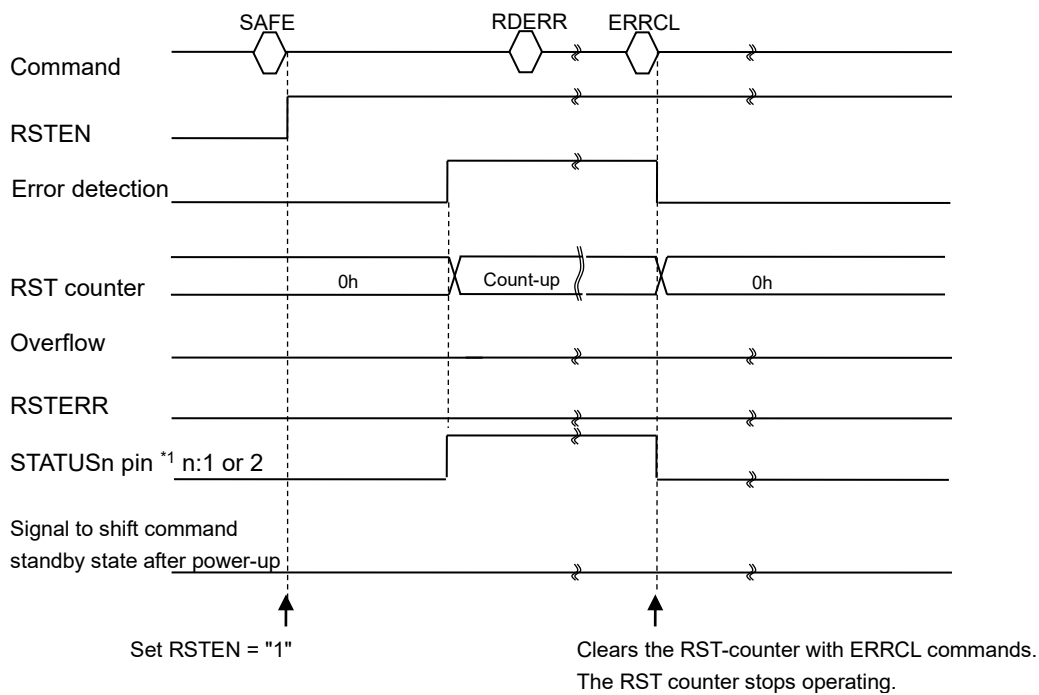

*1 Misoperation detection and failure detection outputs are selected by OUTSTAT command.

The operation when no ERRCL command is entered is as follows.

<When "Transition to the command standby state after power-up" is selected by the overflow of the RST counter>

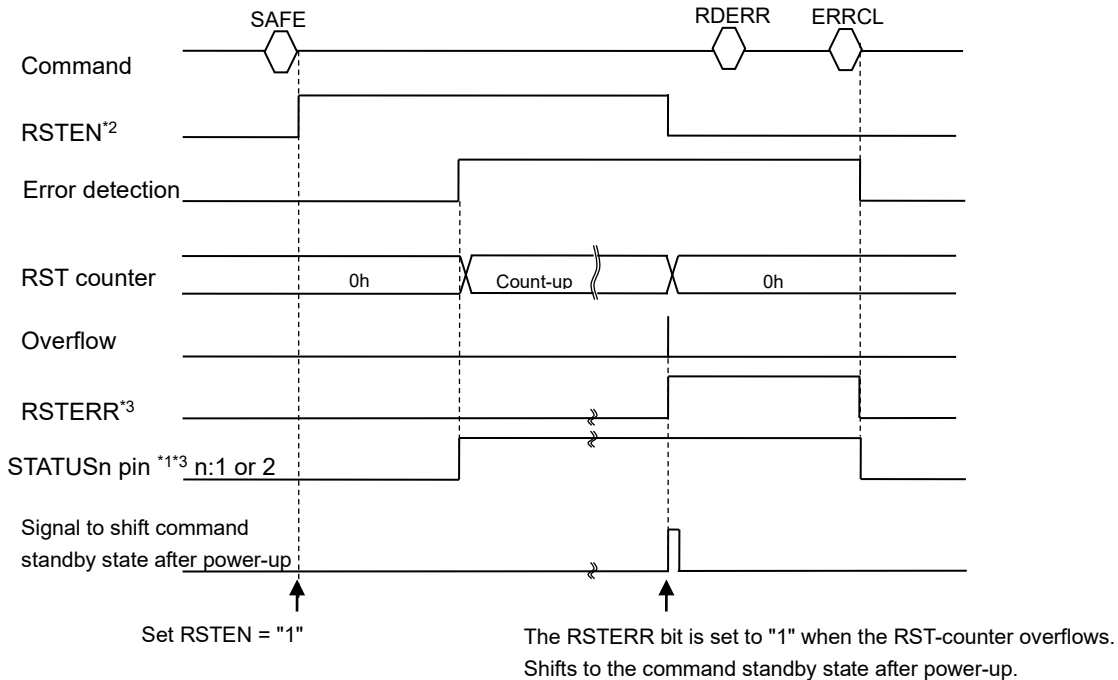

*1 Misoperation detection and failure detection outputs are selected by OUTSTAT command.

*2 If transferring to the command standby state after power-up is executed by the overflow of the RST counter, each bit of SAFE command is cleared. Also, error bits readable by RDERR command are cleared by ERRCL command.

*3 Even if transferring to the command standby state after power-up is executed by the overflow of the RST counter, error bits readable by RDERR command and the state configured by OUTSTAT command remain.

< When "Transition to the command standby state after power-up " is not selected by the overflow of the RST counter >

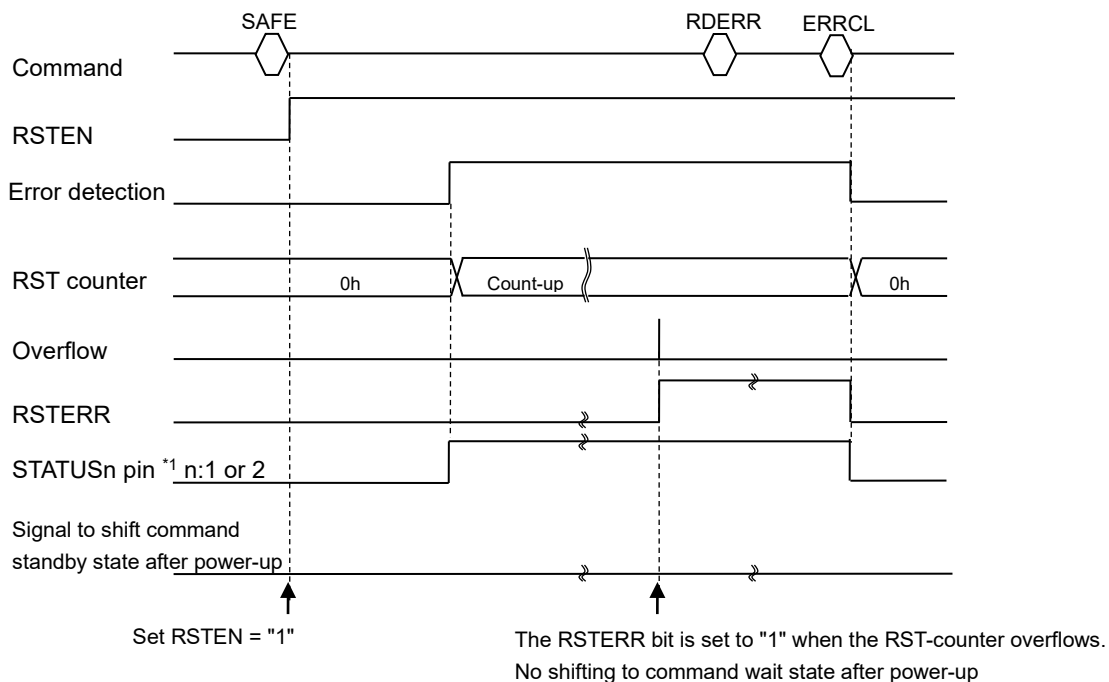

*1 Misoperation detection and failure detection outputs are selected by OUTSTAT command.

◆ Detects the stop of clock input from a crystal resonator or ceramic resonator.

Set the "Detects the stop of clock input from a crystal resonator or ceramic resonator" with the OSCEN bit of the SAFE command.

When the clock input from the crystal resonator or the ceramic resonator is stopped, the error bit (OSCERR) is set to "1". At the same time, the clock backup function is activated and the clock is automatically switched to the RC oscillator circuit (4.096MHz).

Error bit (OSCERR) can be read with RDERR command. However, if the RDERR command (first byte) is inputted before the crystal or ceramic resonator stops and switches to RC oscillation (about 500μs), the CBUSYB pin will remain "L". Therefore, read the command after the CBUSYB pin becomes "H". Also, error bit (OSCERR) can be cleared by ERRCL command. However, if the clock input from the crystal resonator or the ceramic resonator continues to be stopped while the OSCEN bit of the SAFE command is "1", the error bit (OSCERR) is set to "1".

When the crystal resonator or the ceramic resonator stops and switches to RC oscillation, playback may become abnormal. Therefore, after confirming that the error bit (OSCERR) is "1", enter STOP command to stop playback.

If the clock input from the crystal resonator or the ceramic resonator is stopped while the OSCEN bit is "0", the error bit (OSCERR) does not change to "1", but the clock backup function is activated and the clock backup circuit is automatically switched to the RC oscillator circuit (4.096MHz).

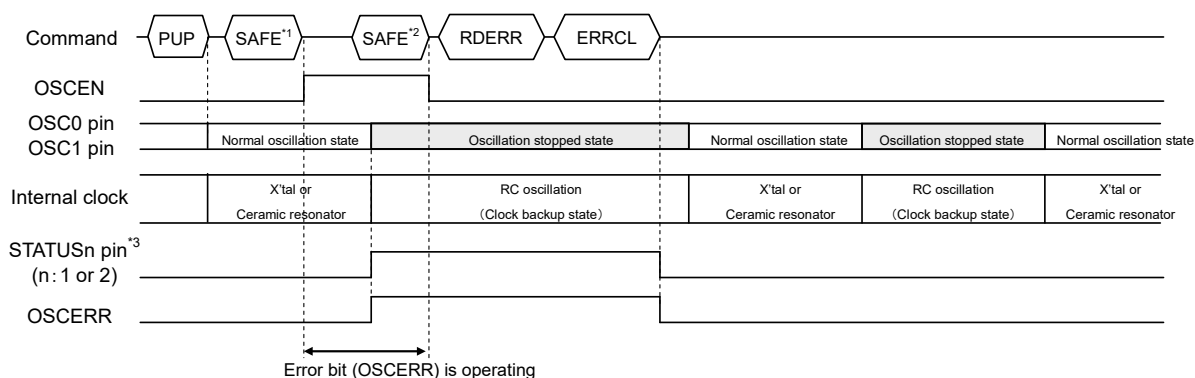

*1 Set OSCEN = "1"

*2 Set OSCEN = "0"

*3 Misoperation detection and failure detection outputs are selected by OUTSTAT command.

<When the OSCEN bit of SAFE command continue to be "1">

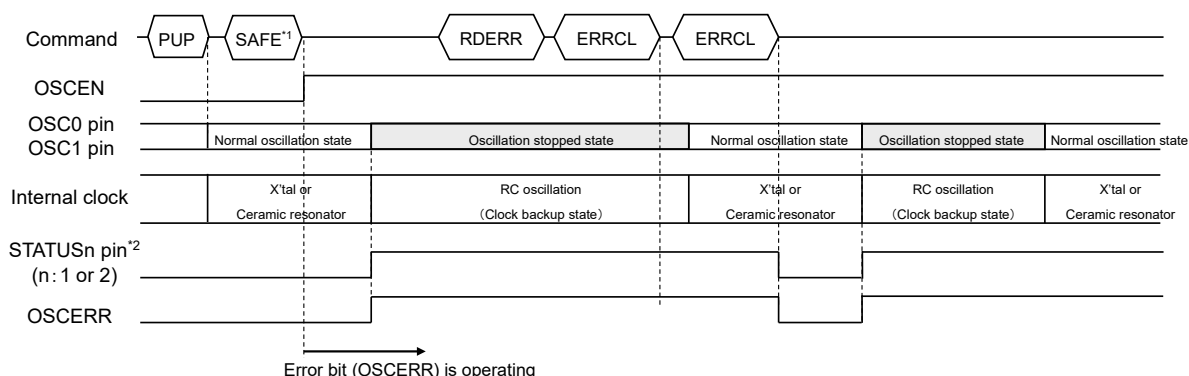

*1 Set OSCEN = "1"

*2 Misoperation detection and failure detection outputs are selected by OUTSTAT command.

◆ Detects disconnection/short circuit of BCLK.

Set the "Detects disconnection/short circuit of BCLK" with the BCKEN bit of the SAFE command.

When the BCLK is stopped, the error bit (BCKERR) is set to "1".

Error bit (BCKERR) can be read with RDERR command. Also, error bit (BCKERR) can be cleared by ERRCL command.

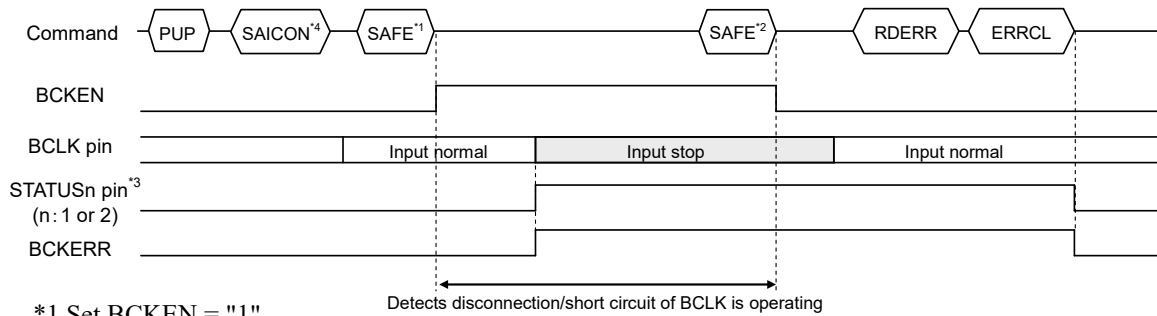

*1 Set BCKEN = "1"

*2 Set BCKEN = "0"

*3 Misoperation detection and failure detection outputs are selected by OUTSTAT command.

*4 Set OUTEN = "1" or INEN = "1"

◆ Detects disconnection/short circuit of LRCLK.

Set the "Detects disconnection/short circuit of LRCLK" with the LRCKEN bit of the SAFE command.

When the LRCLK is stopped, the error bit (LRCKERR) is set to "1".

Error bit (LRCKERR) can be read with RDERR command. Also, error bit (LRCKERR) can be cleared by ERRCL command.

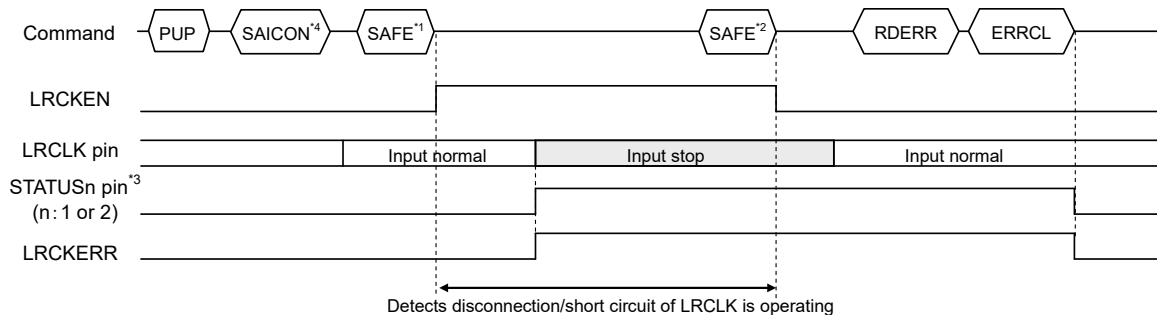

*1 Set LRCKEN = "1"

*2 Set LRCKEN = "0"

*3 Misoperation detection and failure detection outputs are selected by OUTSTAT command.

*4 Set OUTEN = "1" or INEN = "1"

< When SAFE command LRCKEN bit is "0" >

Disconnection or short circuit of LRCLK is not detected.

When LRCLK is faster than 5%, SAICH is initialized and the recorder stops playing.*5 At that time, the error bit (LRCKERR) keeps "0".

< When SAFE command LRCKEN bit is "1" >

Disconnection or short circuit of LRCLK is detected.

When LRCLK is faster than 5%, SAICH is initialized and the recorder stops playing.*5 At that time, the error bit (LRCKERR) changes "1".

*5 : The unit does not recover even if a normal LRCLK is input after stopping playback. Enter MUON command → SAICH command after inputting a normal LRCLK.

◆ Detects disconnection/short circuit of SAI_IN.

Set the "Detects disconnection/short circuit of SAI_IN" with the SAIINEN bit of the SAFE command.

When SAI_IN does not change for more than 1.8 seconds (min.), the error bit (SAIINERR) is set to "1".

Error bit (SAIINERR) can be read with RDERR command. Also, error bit (SAIINERR) can be cleared by ERRCL command. When OUTEN is set to "1" and INEN is set to "0" by the SAICON command, the SAI_IN input is disabled. Therefore, set SAIINEN to "0".

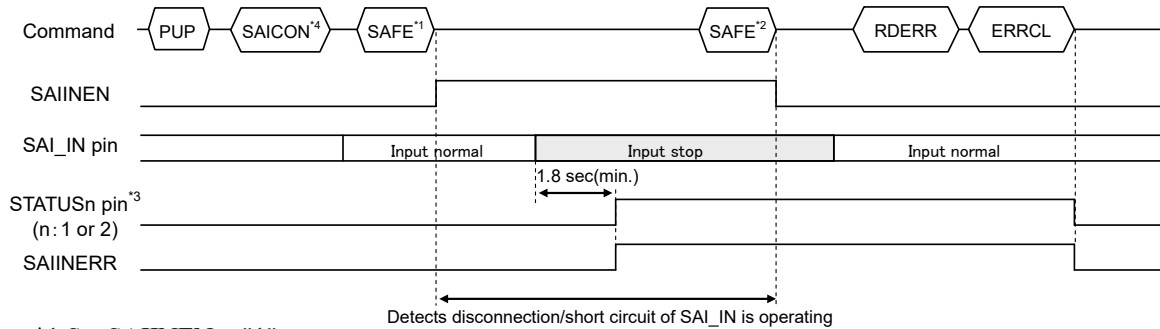

*1 Set SAIINEN = "1"

*2 Set SAIINEN = "0"

*3 Misoperation detection and failure detection outputs are selected by OUTSTAT command.

*4 Set INEN = "1"

◆ Mixing number error detection

When using the serial audio interface (SAI), the sampling frequency limits the maximum number of mixings and playable channels. If the setting exceeds the limit, it will be detected as a mixing error.

Set the mixing error detection with the MIXEN bit of the SAFE command.

- ① When FS3 to FS0 = 12/24/48 kHz or 11.025/22.05/44.1 kHz is set by the SAICON command, and either LEN or REN is set to "1" by the SAICH command, specifying channel 3 and inputting the PLAY, PLAY2, START or MUON command sets the error bit (MIXERR) to "1". Also, the input command is ignored.
- ② If FS3 to FS0 = 12/24/48 kHz or 11.025/22.05/44.1 kHz is set by the SAICON command, and if the Rch or Lch side selects channel 3 (CH3) by the SAICH command and either LEN or REN is set to "1", the error bit (MIXERR) is set to "1". Also, the entered SAICH command is ignored.

Error bit (MIXERR) can be read with RDERR command. Also, error bit (MIXERR) can be cleared by ERRCL command.

For mixing restriction when using serial audio interface (SAI), refer to "Restrictions when using Serial Audio Interface (SAI)" in the chapter on mixing function.

◆ Playback sound error detection

The playback sound error detection function detects error when the sound being played back by this LSI sounds different from the expected sound due to distortion, etc.

The error is detected by fetching the output of the speaker of this LSI from inside or outside of the LSI and comparing it with the playback data.

Connect the FB1 and the FB2 to the SPP and SPM to detect errors in the playback sound outside the LSI.

For details on the playback sound error detection function, refer to How to use the playback sound error detection function.

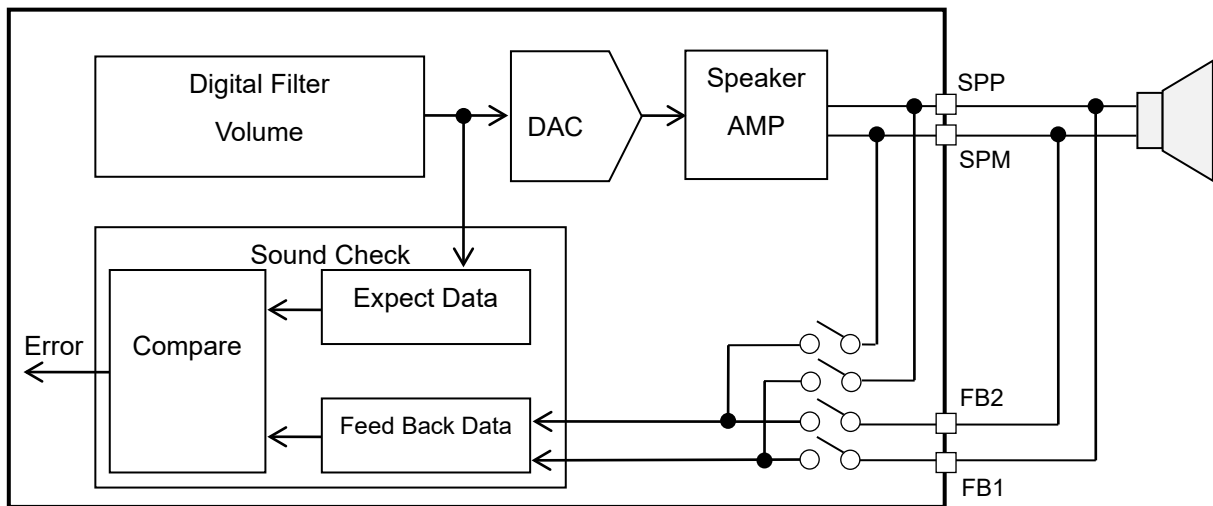

● Serial flash memory rewrite function

The serial flash memory can be rewritten in the following two ways.

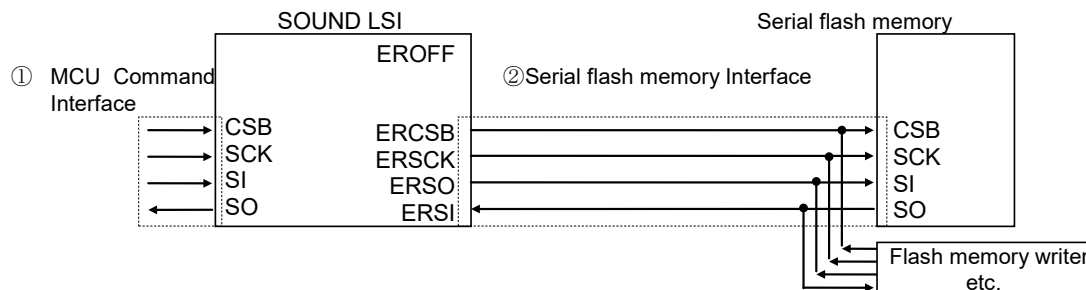

① Rewrite using the clock synchronous serial interface of the MCU command interface

By using the CSB, SCK, SI and SO pins, which are clock synchronous serial interfaces of the MCU command interface the serial flash memory can be rewritten. When the PUP command and FDIRECT command are entered with the EROFF pin set to "L", direct access to the serial flash memory is enabled from the CSB, SCK, SI and SO pins. When returning to the normal mode, insert a reset to initialize (RESETB pin is "L" level.) or shut off the power.

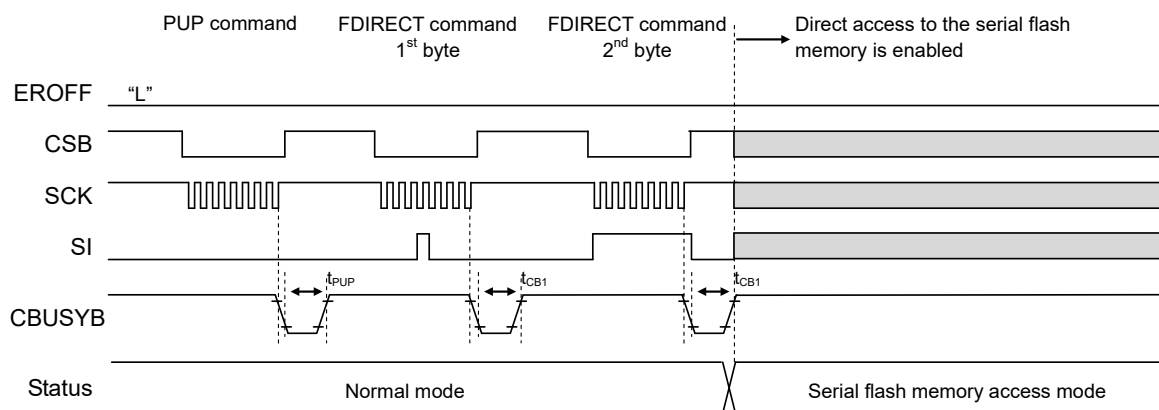

For the PUP command, refer to the "PUP command" in the "Command" section. For the FDIRECT command, refer to the "FDIRECT command" in the "Command" section.

② Rewrite using serial flash memory interface without this LSI

The serial flash memory can be rewritten using the ERCSB, ERCSK, ERSI and ERSO pins that is the serial flash memory interface.

When the EROFF pin set to "H", the serial flash memory can be rewritten using the ERCSB, ERCSK, ERSI and ERSO pins without this LSI. (ERCSB, ERCSK and ERSO pins are in a condition of high-impedance.)

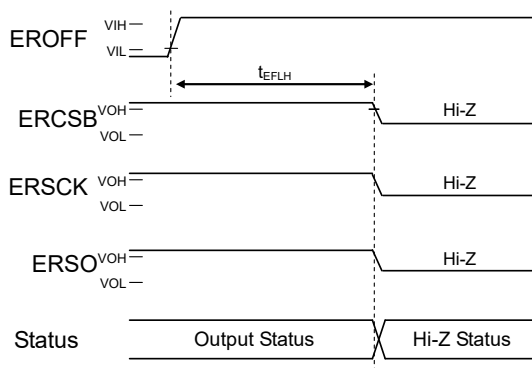

■ Timing chart

● Common

◆ Power-on timing

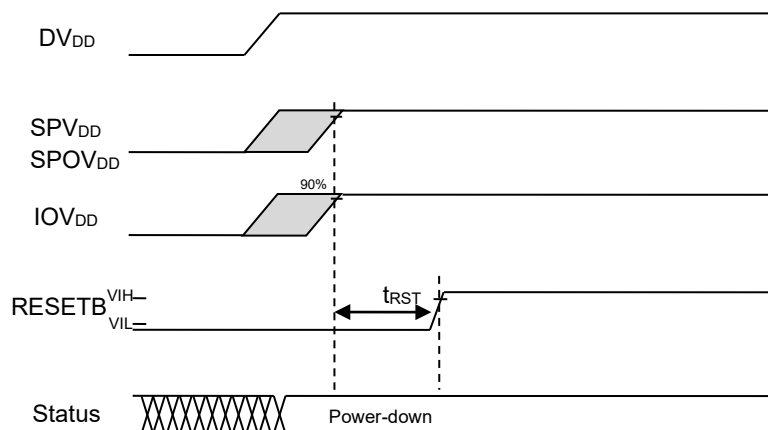

After the power is turned on, the device enters the power-down state.

Start up in the order of DV_{DD} , SPV_{DD} and IOV_{DD} or DV_{DD} , IOV_{DD} and SPV_{DD} .

It is possible that the DV_{DD} and SPV_{DD} start up at the same time and then the IOV_{DD} starts up, or the DV_{DD} and IOV_{DD} starts up at the same time and then the SPV_{DD} starts up.

The DV_{DD} , SPV_{DD} and IOV_{DD} can also start up at the same time.

t_{RST} is specified based on the last power-on pin.

Be sure to input "L" to the RESETB pin before inputting the first command after power-on.

Be sure to enter "L" at the RESETB pin when the DV_{DD} is below the (recommended) operating voltage range.

◆ Power-off timing

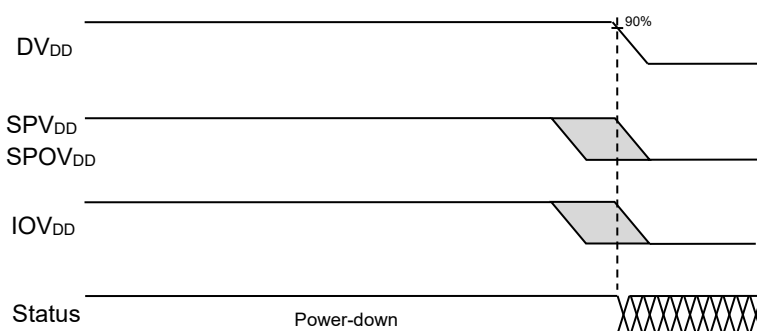

Shut down in the order of IOV_{DD} , SPV_{DD} , and DV_{DD} or SPV_{DD} , IOV_{DD} , and DV_{DD} .

It is possible that the IOV_{DD} shuts down and then the SPV_{DD} and DV_{DD} shuts down at the same time, or the SPV_{DD} shuts down and then the IOV_{DD} and DV_{DD} shut down at the same time.

The DV_{DD} , SPV_{DD} and IOV_{DD} can also shut down at the same time.

Shut down each power supply after changing to the power down status with PDWN commands.

◆ Reset input timing

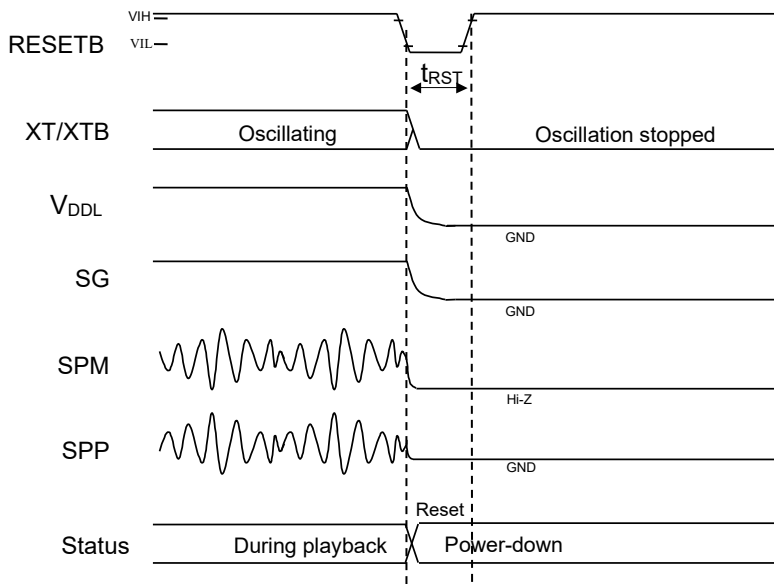

The same timing is applied when a reset is input during command standby.

◆ SAI interface timing (slave)

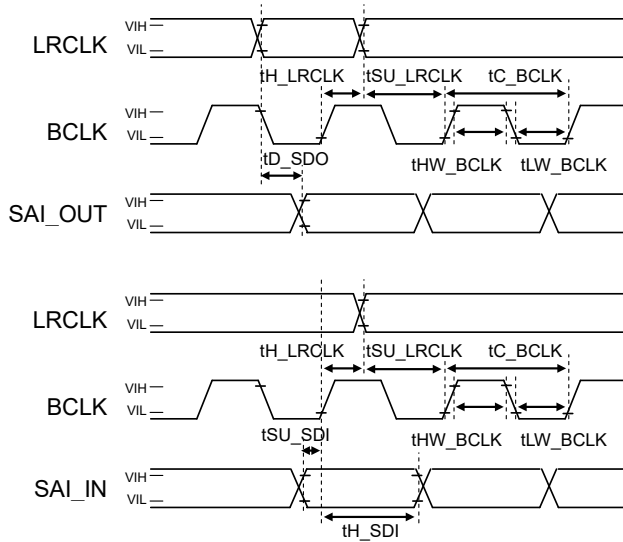

◆ Serial flash memory interface timing

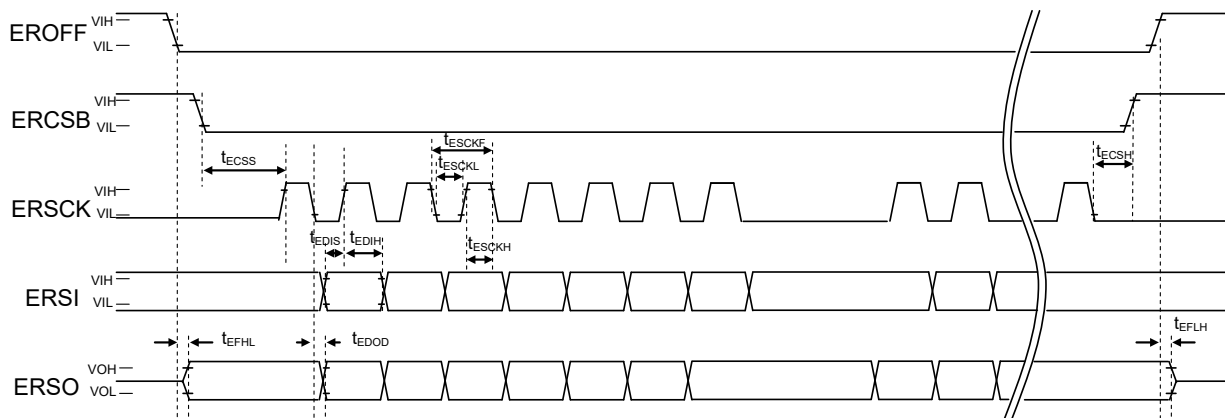

● Clock synchronous serial

◆ Clock Synchronous Serial Interface Timing (SCK Initial Value = "H" Level)

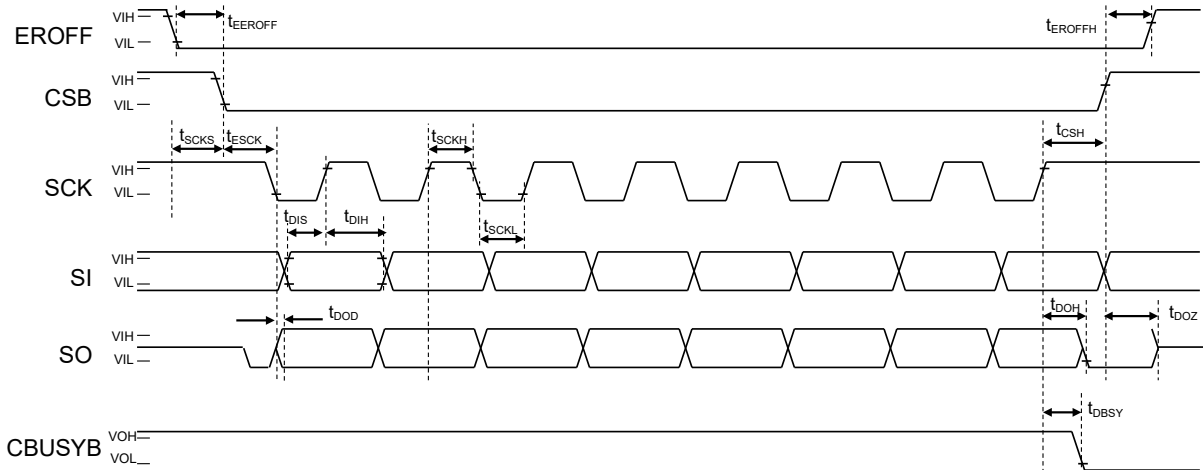

◆ Clock Synchronous Serial Interface Timing (SCK Initial Value = "L" Level)

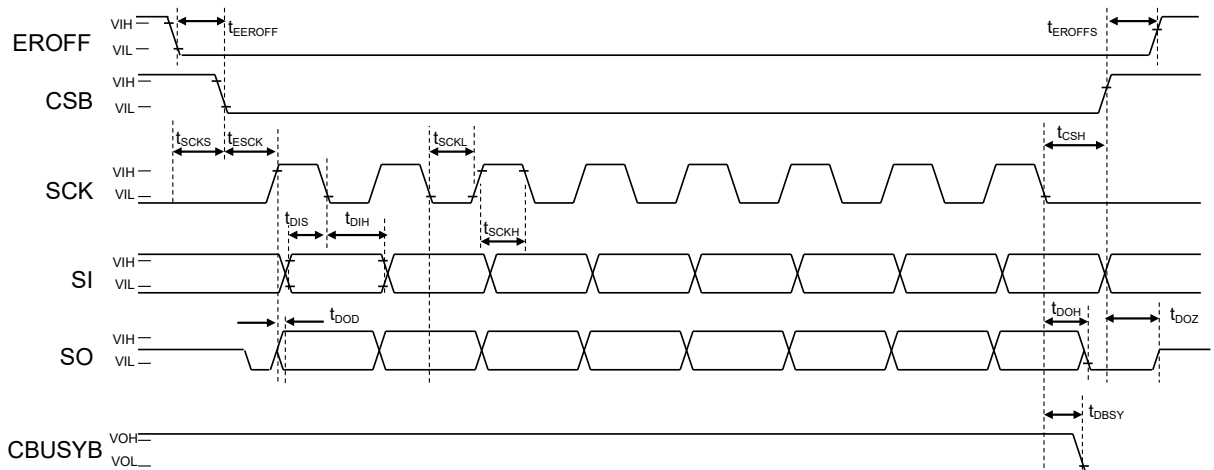

◆ Power-up timing

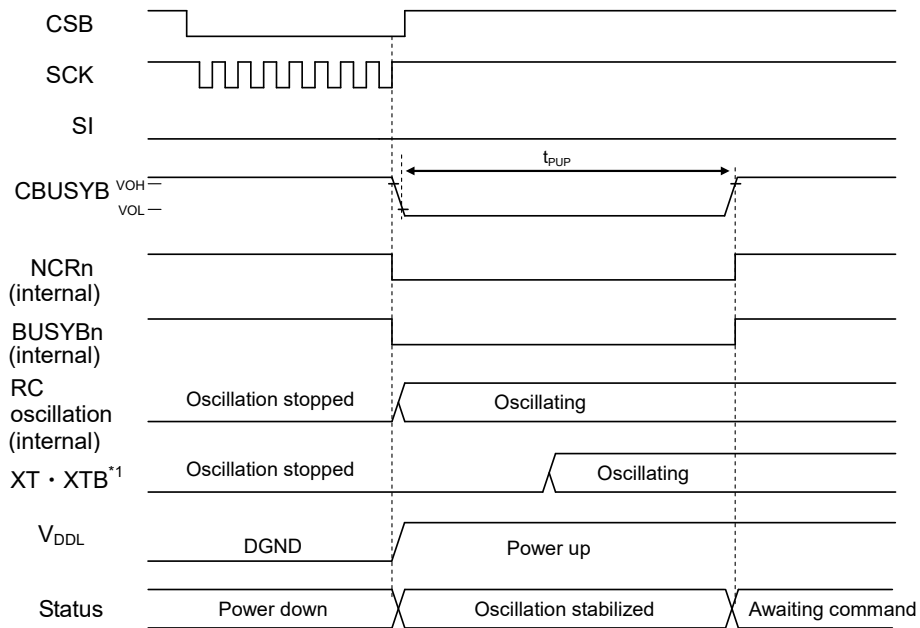

*1 When using a crystal or ceramic resonator

◆ Power-down timing

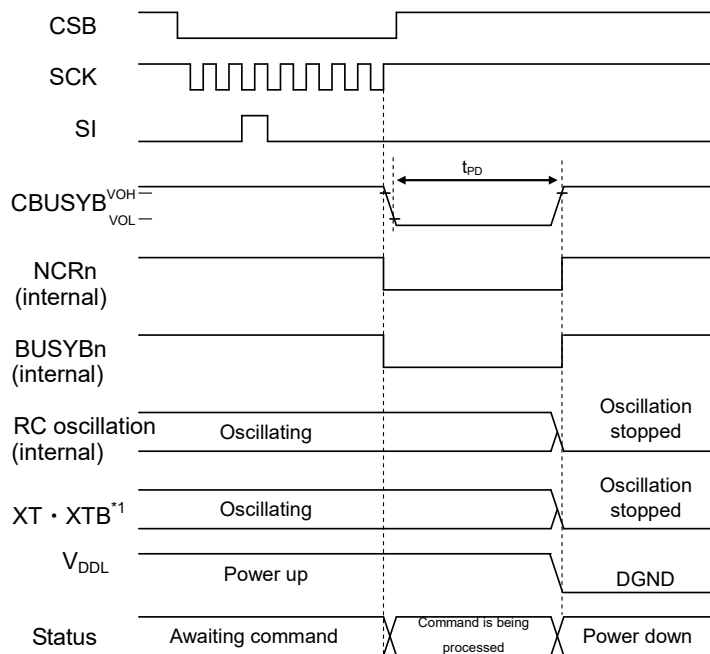

*1 When using a crystal or ceramic resonator

◆ Speaker amplifier power-up timing (DAMP bit = "0", AEN1 bit = "0", AEN0 = bit "0" → "1")

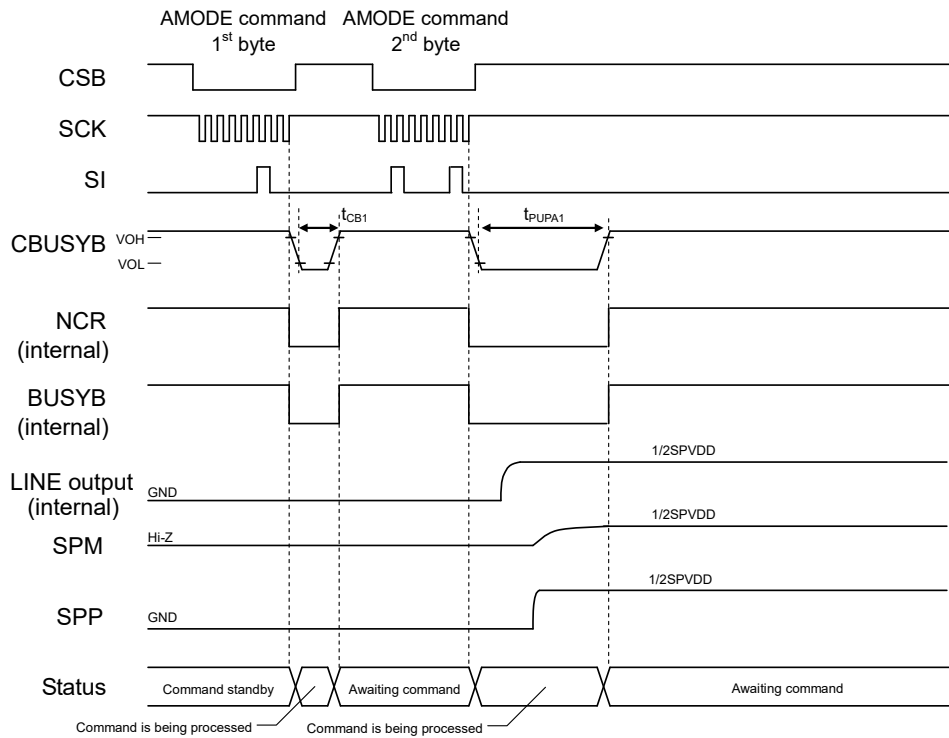

◆ Line amplifier power-up timing (DAMP bit = "0", POP bit = "1", AEN1 bit = "0" → "1", AEN0 bit = "0")

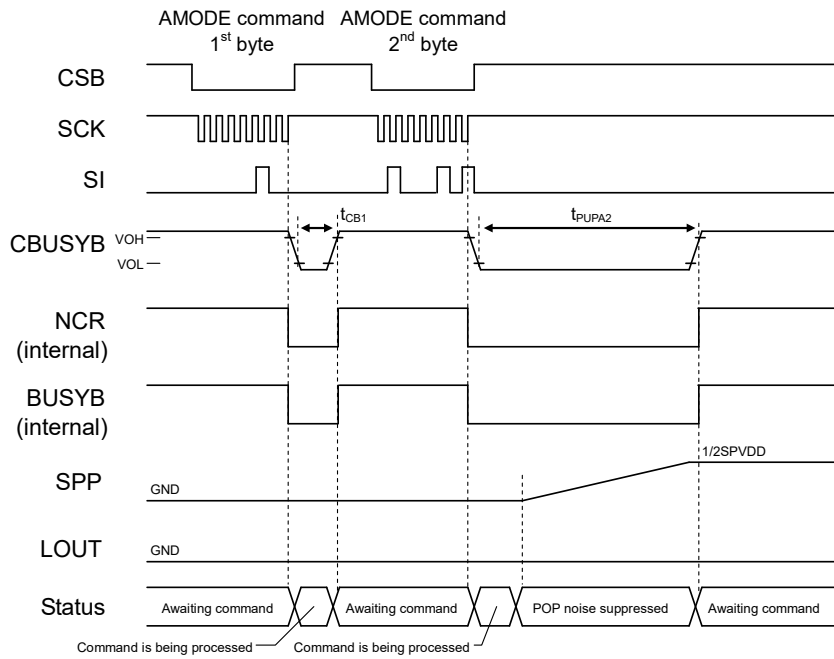

◆ Line amplifier power-up timing (DAMP bit = "0", POP bit = "0", AEN1 bit = "0" → "1", AEN0 bit = "0")

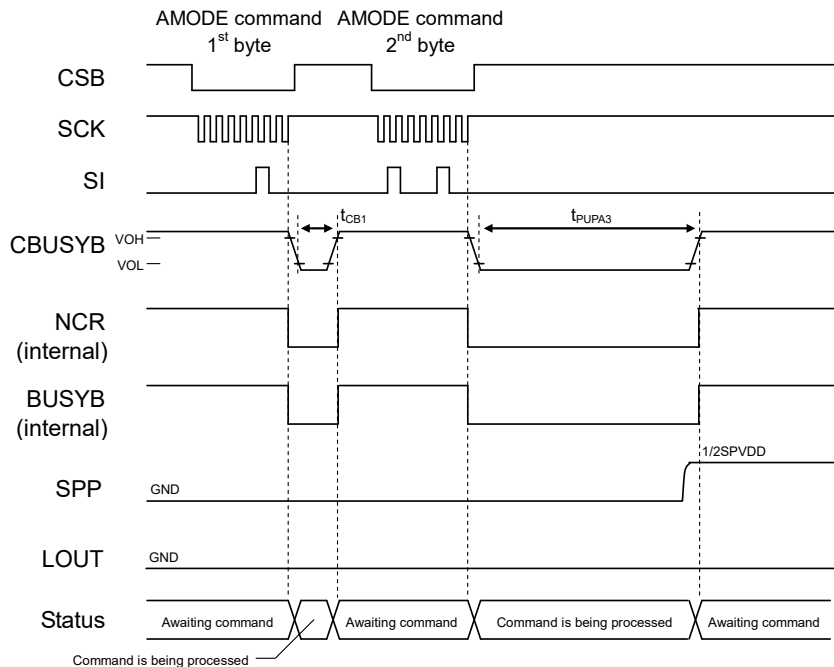

◆ Line amplifier power-up timing (DAMP bit = "0", POP bit = "1", AEN1 bit = "0" → "1", AEN0 bit = "0" → "1")

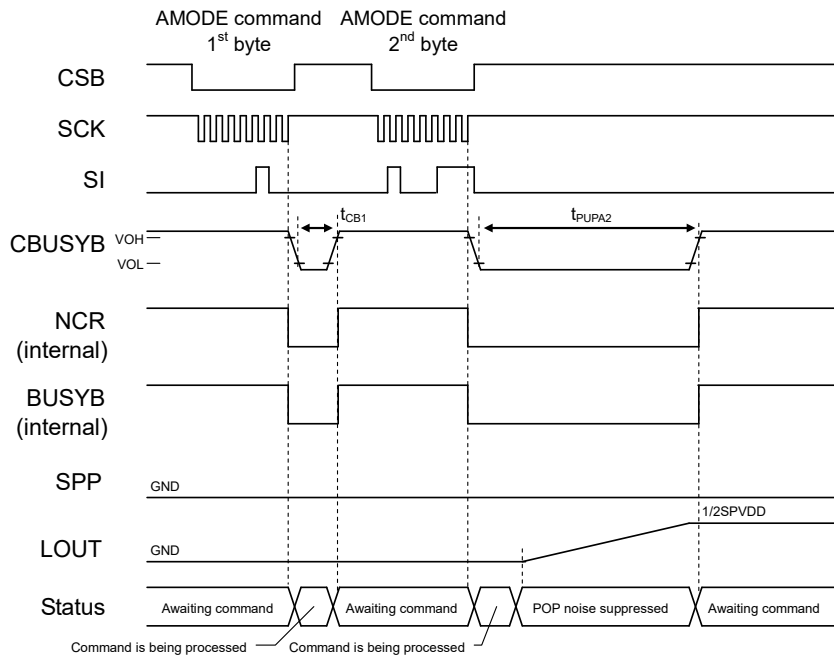

◆ Line amplifier power-up timing (DAMP bit = "0", POP bit = "0", AEN1 bit = "0" → "1", AEN0 bit = "0" → "1")

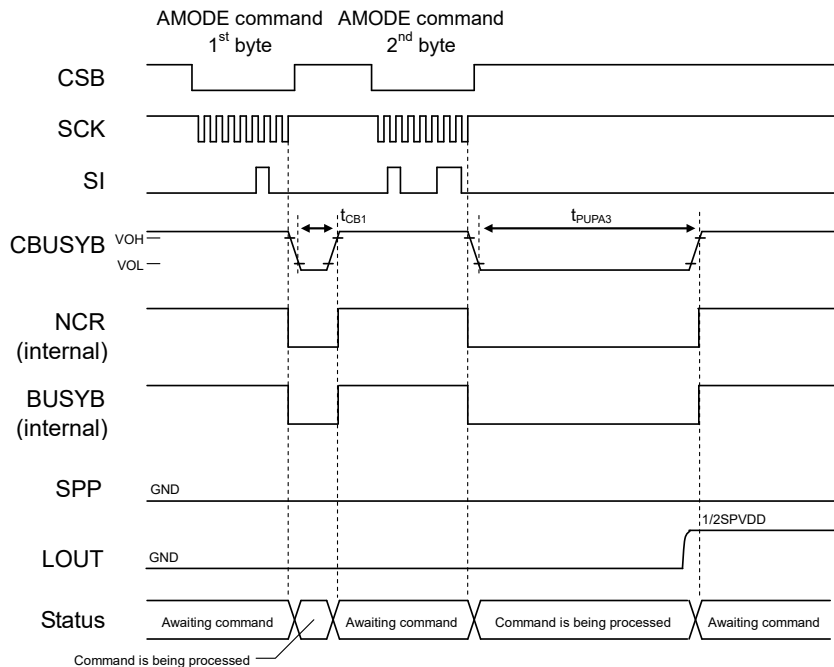

◆ Speaker amplifier power-down timing (DAMP bit = "0", AEN1 bit = "0", AEN0 bit = "1" → "0")

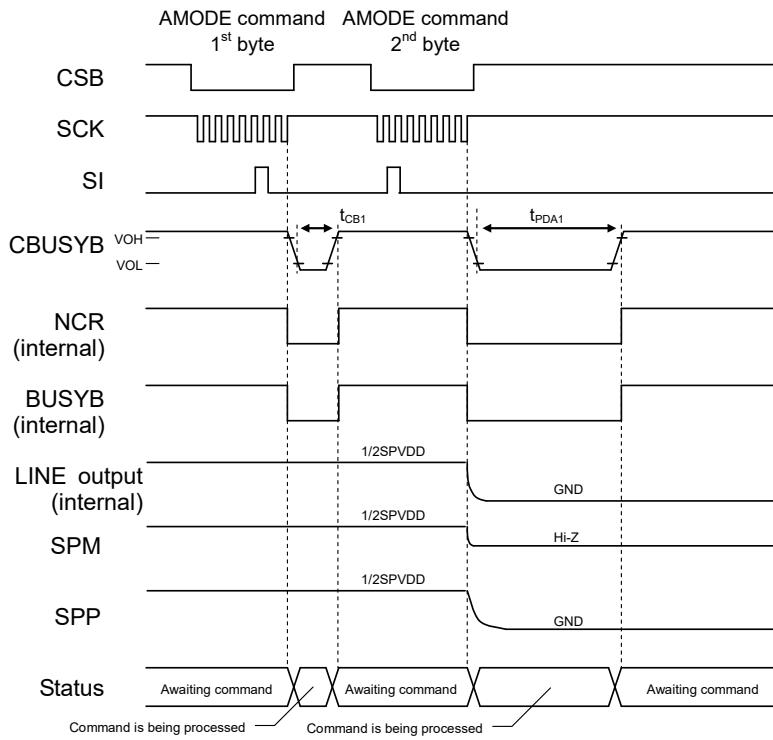

◆ Line amplifier power-down timing (DAMP bit = "0", POP bit = "1", AEN1 bit = "1" → "0", AEN0 bit = "0")

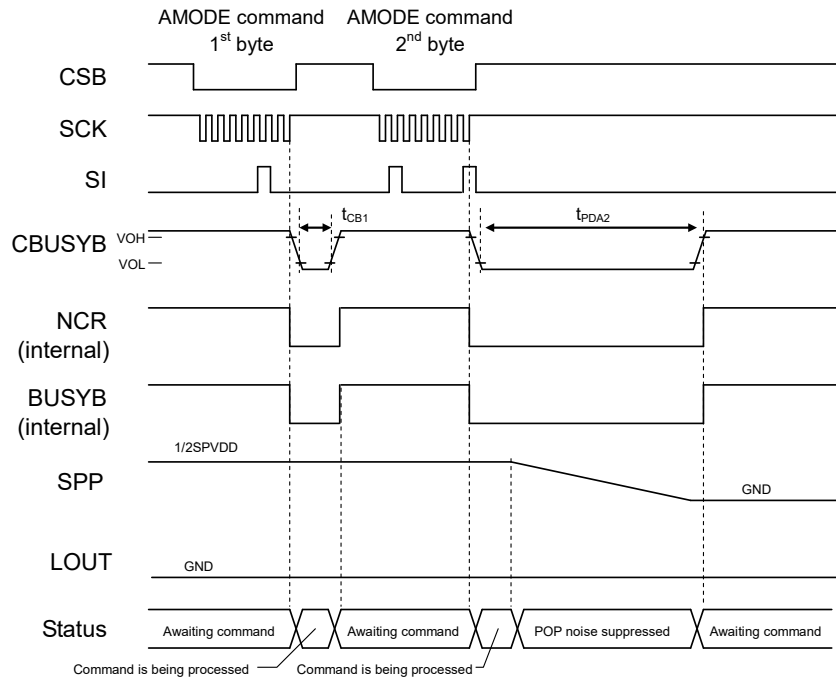

◆ Line amplifier power-down timing (DAMP bit = "0", POP bit = "0", AEN1 bit = "1" → "0", AEN0 bit = "0")

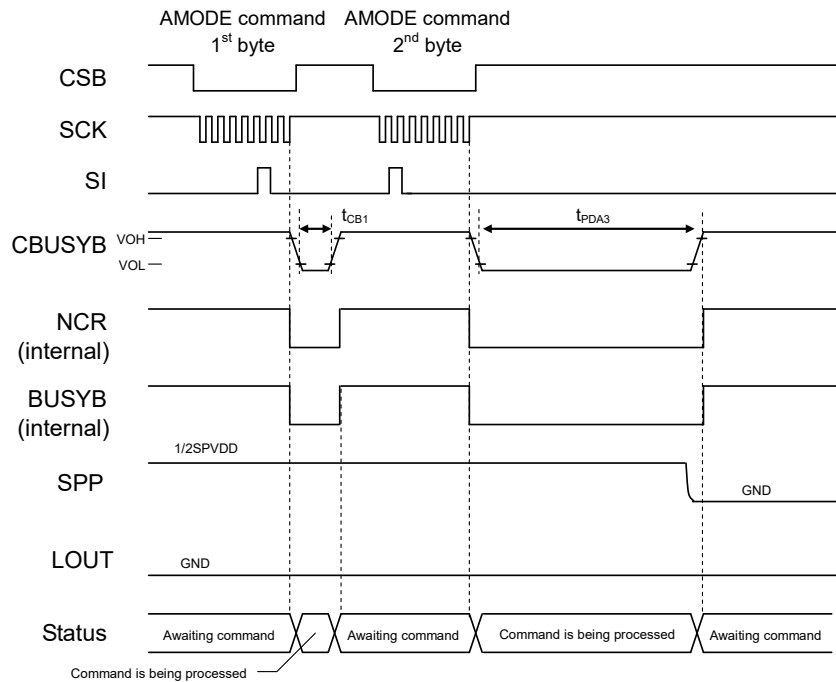

◆ Line amplifier power-down timing (DAMP bit = "0", POP bit = "1", AEN1 bit = "1" → "0", AEN0 bit = "1" → "0")

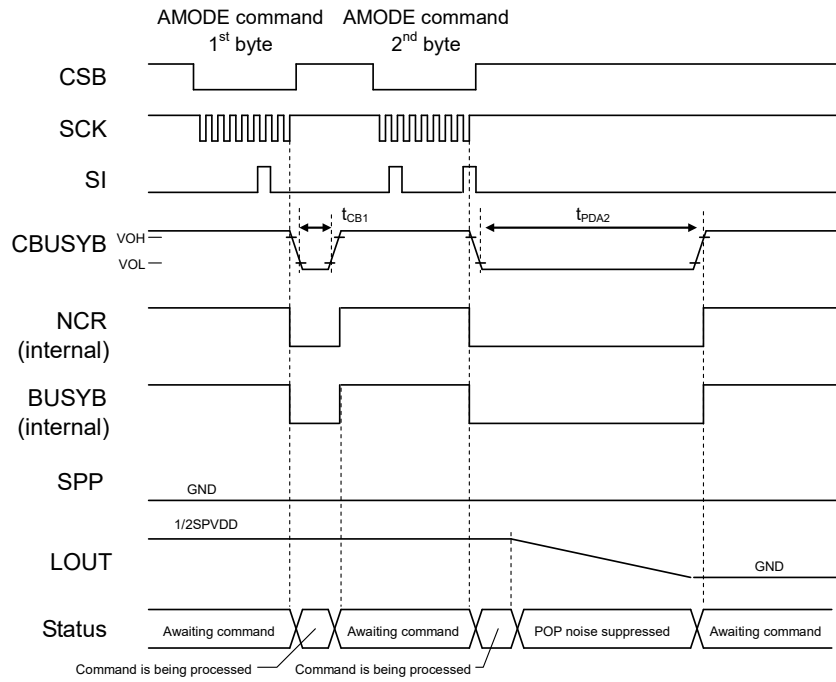

◆ Line amplifier power-down timing (DAMP bit = "0", POP bit = "0", AEN1 bit = "1" → "0", AEN0 bit = "1" → "0")

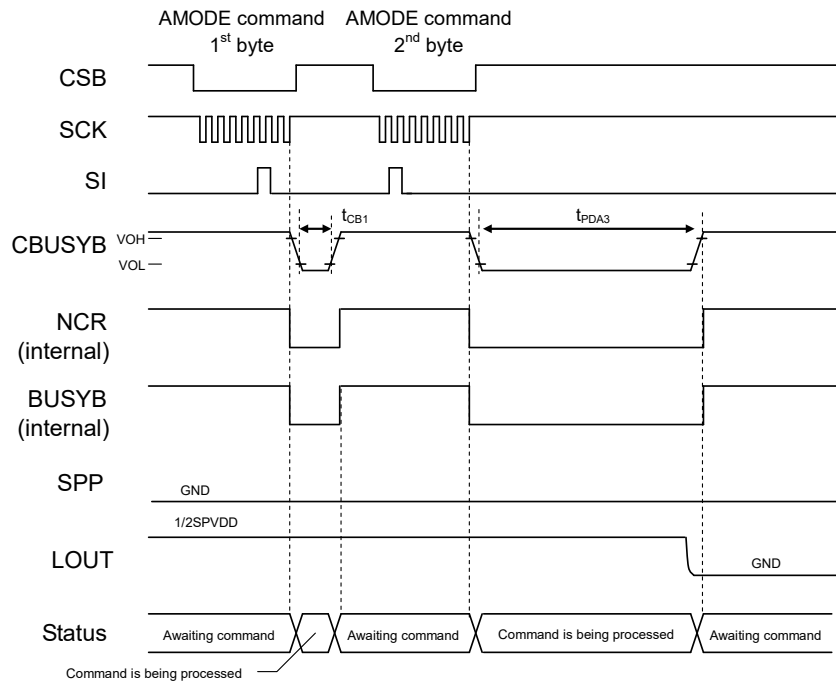

◆ FDIRECT command timing

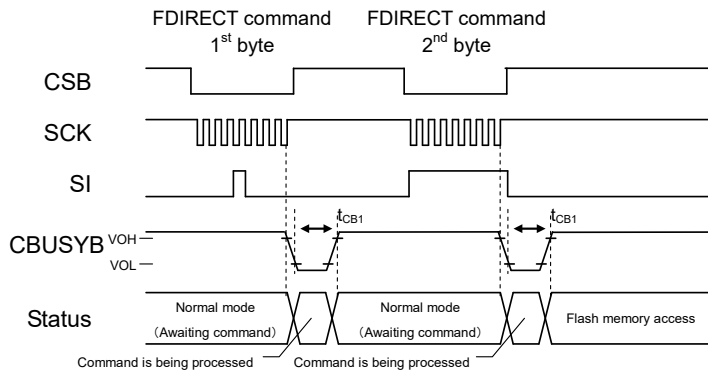

◆ WDTCL command timing

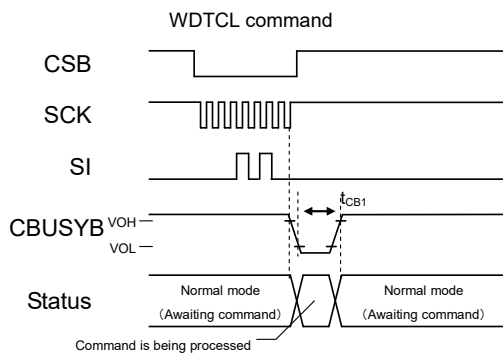

◆ Change volume timing by AVOL command

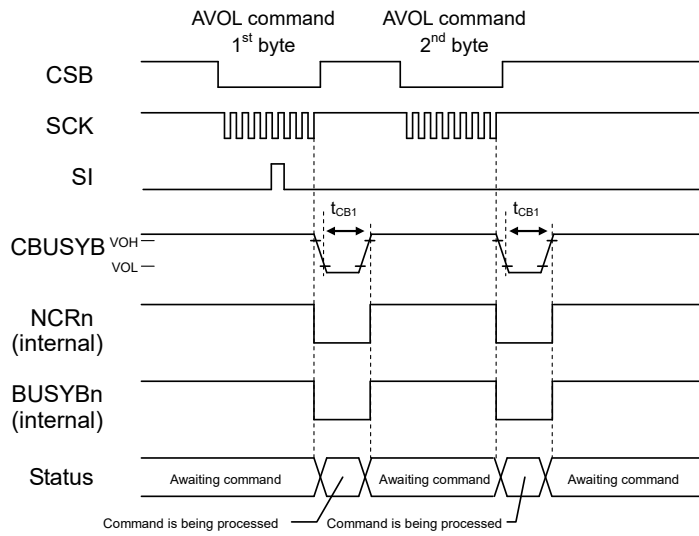

Speaker amplifier volume setting by AVOL commands is valid only when Class AB speaker amplifier is used. When a Class D speaker amplifier is used, the setting value is ignored and +0.0dB is selected.

◆ FADE command timing

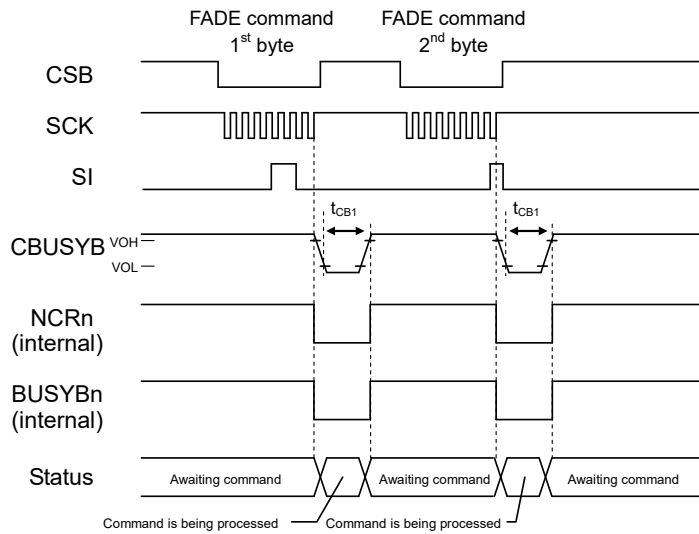

◆ Setting playback phrases using FADR command

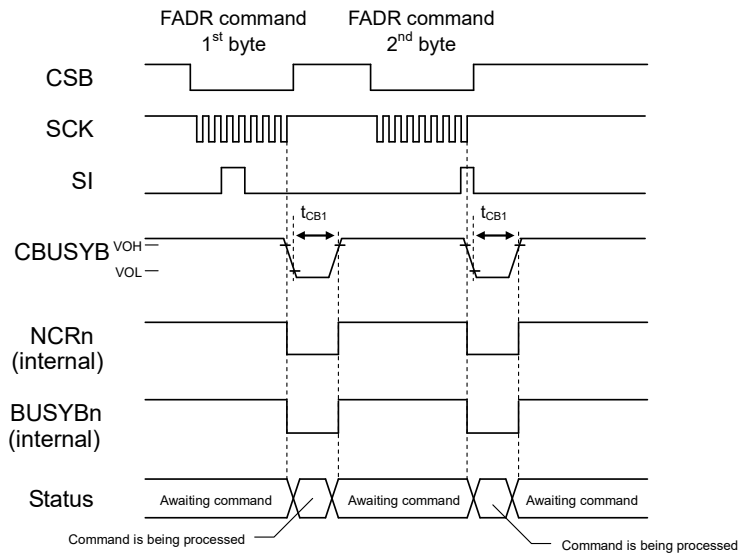

◆ Playback start timing by PLAY command

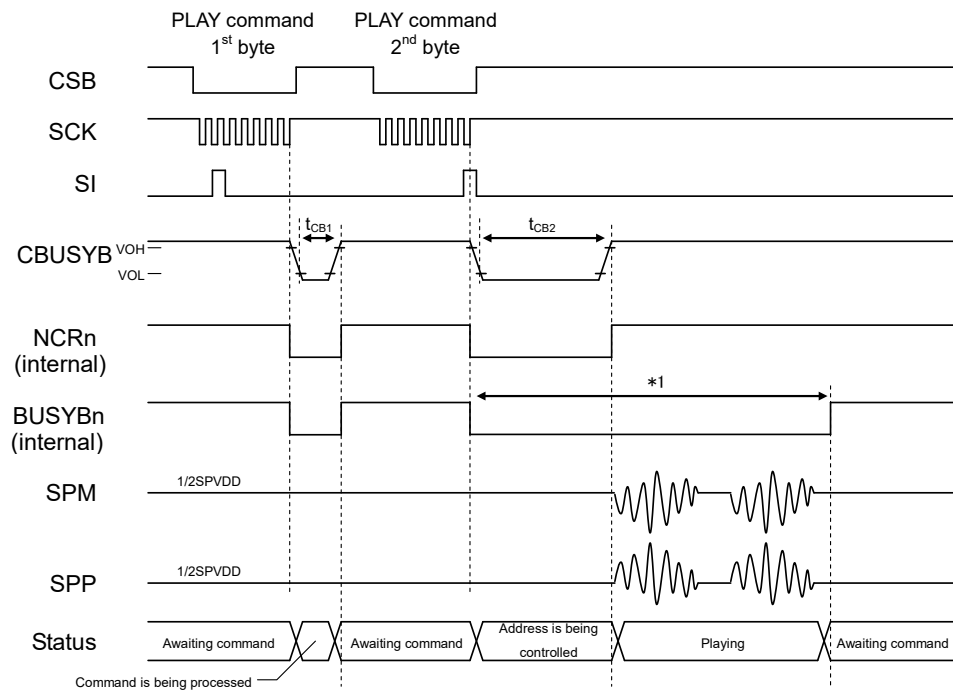

When the first byte of the PLAY command is input, the device waits for the input of the second byte after the command processing time (t_{CB1}). When the second byte is entered, the address data of the phrase to be played after the command processing time (t_{CB2}) is read from the flash memory.

When the phrase address data is read, the specified phrase starts playback, and when playback is completed, the BUSYB signal of the playback channel becomes "H" level.

The NCR signal goes to the "L" level during playback preparation, and goes to the "H" level when playback preparation is completed and playback starts. When the NCR signal of the playback channel becomes "H" level, the PLAY command of the next phrase to be played can be accepted.

*1 The length of the "L" interval in the BUSYBn is (t_{CB2} + sound production time).

◆ Continuous playback timing by PLAY command

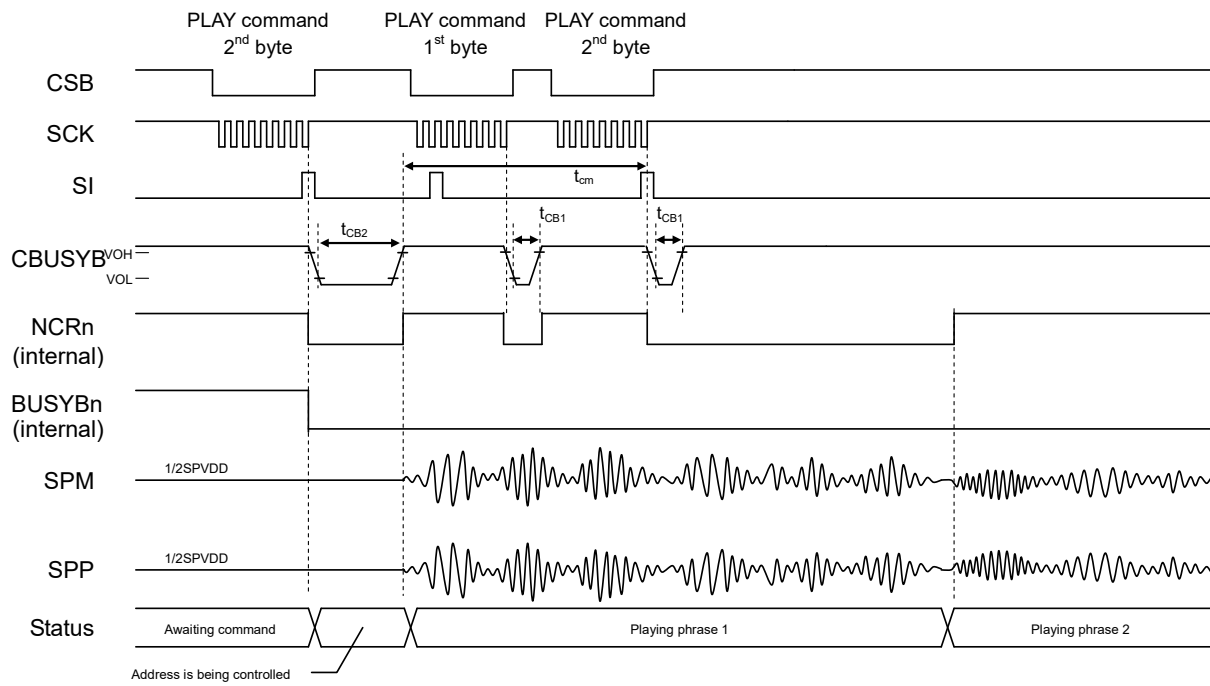

When making continuous playbacks, input the PLAY command for the next phrases within the specified time period (t_{cm}) after the NCR of the corresponding channel changes to "H" level, so that the LSI plays back the next phrases without silence sounds after the current phrase playback ends.

When the playback is not continuous, input the PLAY command for the next phrases after confirming the playback is completed by RDSTAT command, etc.

◆ Playback start timing by START command

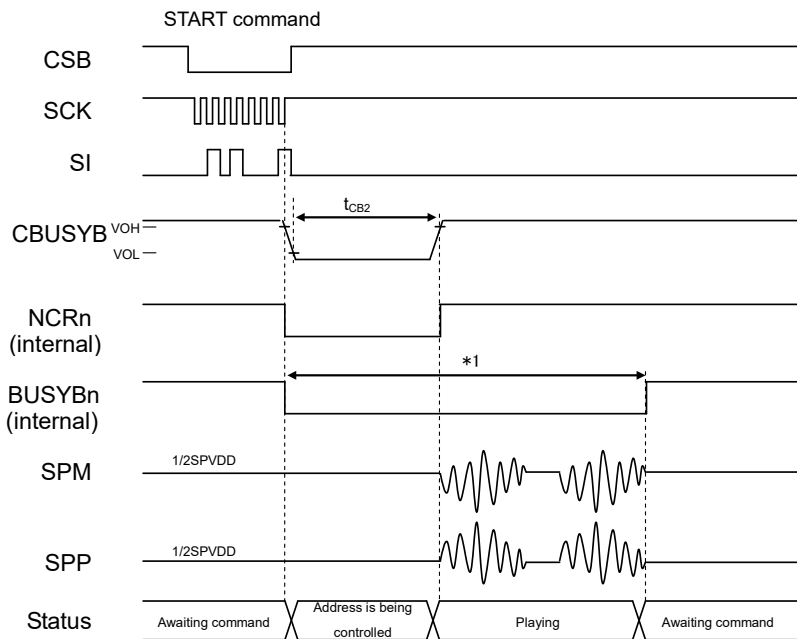

When the START command is input, the address data of the phrase to be played after the command processing time (t_{CB2}) is read from the flash memory. When the phrase address data is read, the specified phrase starts playback, and when playback is completed, the BUSYB signal of the playback channel becomes "H" level.

The NCR signal goes to the "L" level during playback preparation, and goes to the "H" level when playback preparation is completed and playback starts. When the NCR signal of the playback channel becomes "H" level, the START command of the next phrase to be played can be accepted.

*1 The length of the "L" interval in the BUSYBn is (t_{CB2} + sound production time).

◆ Continuous playback timing by START command

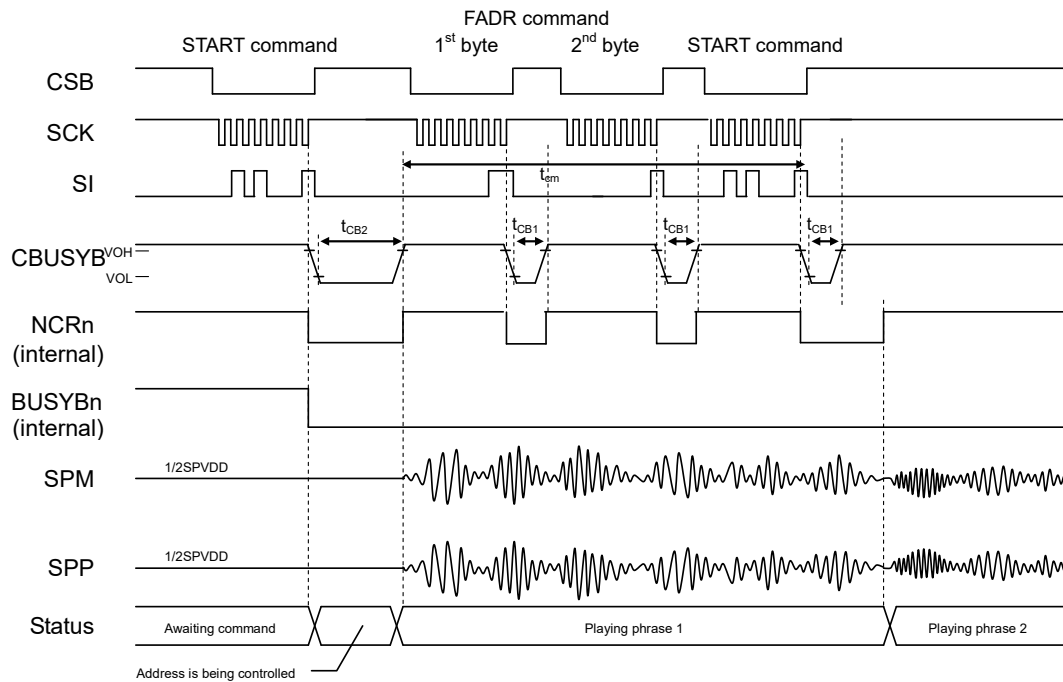

When making continuous playbacks, input the START command for the next phrases within the specified time period (t_{cm}) after the NCR of the corresponding channel changes to "H" level, so that the LSI plays back the next phrases without silence sounds after the current phrase playback ends.

When the playback is not continuous, input the START command for the next phrases after confirming the playback is completed by RDSTAT command, etc.

◆ STOP command (when the FAD bit is "L")

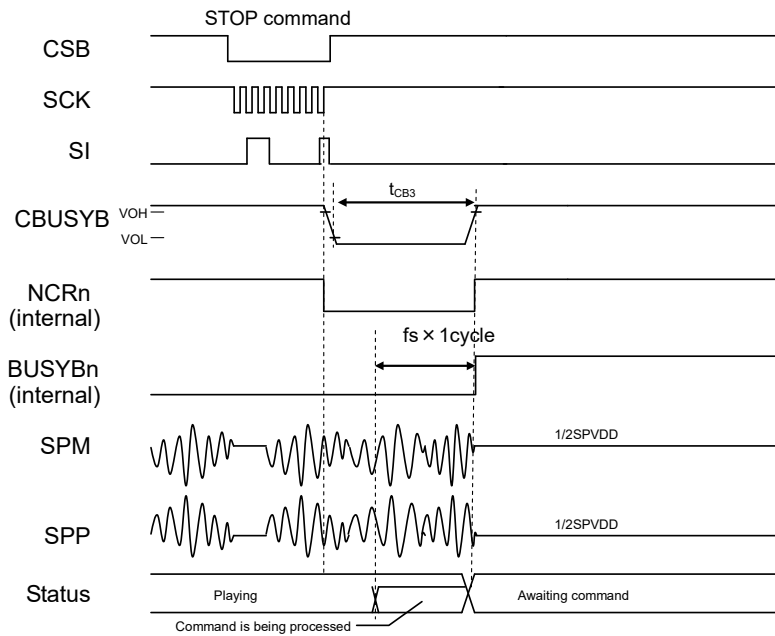

◆ STOP command (when the FAD bit is "H")

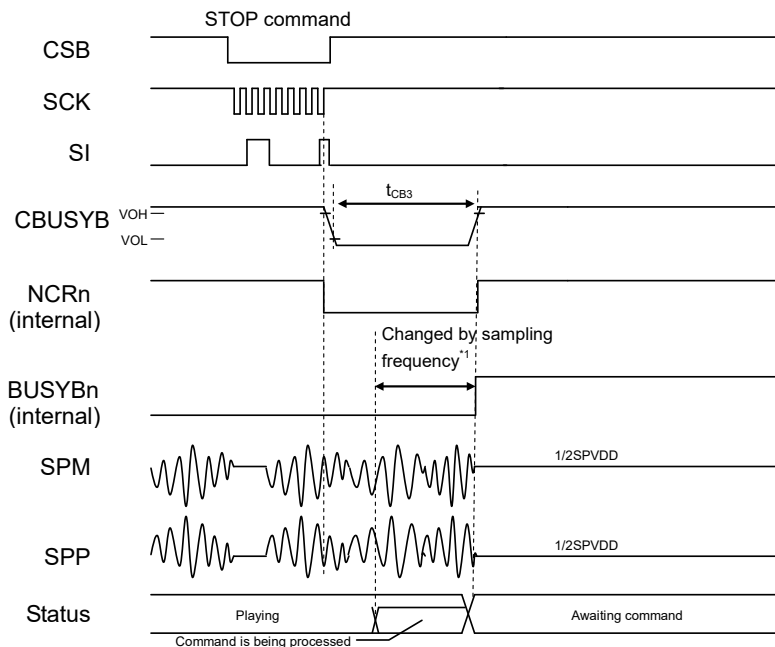

*1 The duration of the BUSYBn varies depending on the sampling frequency groups.

- At 10.7/21.3kHz : Approx. 3ms
- At 6.4/12.8/25.6kHz : Approx. 5ms
- At 8.0/16.0/32.0kHz : Approx. 4ms
- At 11.025/22.05/44.1kHz : Approx. 2.9ms
- At 12.0/24.0/48.0kHz : Approx. 2.7ms

◆ Playback start timing by MUON command

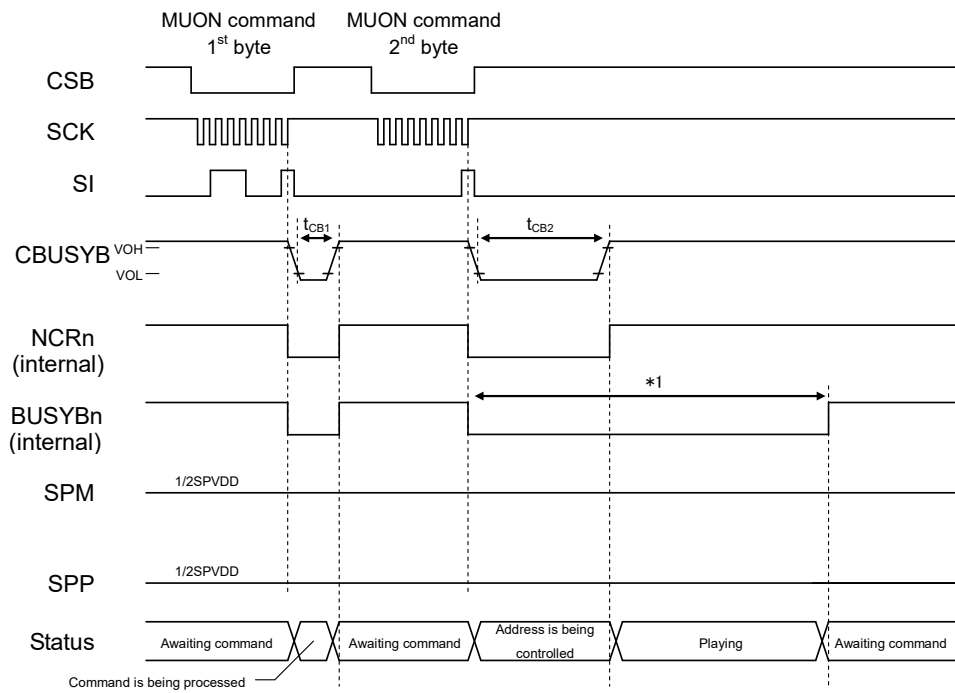

When the first byte of the MUON command is input, the device waits for the input of the second byte after the command processing time (t_{CB1}). When the second byte is entered, the silence time is calculated after the command processing time (t_{CB2}). When the calculation of the silence duration is completed, the calculated silence is played back, and when the playback is completed, the BUSYB signals of the playback channels become "H" level.

The NCR signal becomes "L" level during playback preparation, and becomes "H" level when playback preparation is completed and playback starts. When the NCR signal of the playback channel becomes "H" level, the PLAY command of the next phrase to be played can be accepted.

*1 The length of the "L" interval of the BUSYBn is (t_{CB2} + silence playback time).

◆ Continuous playback timing by MUON command

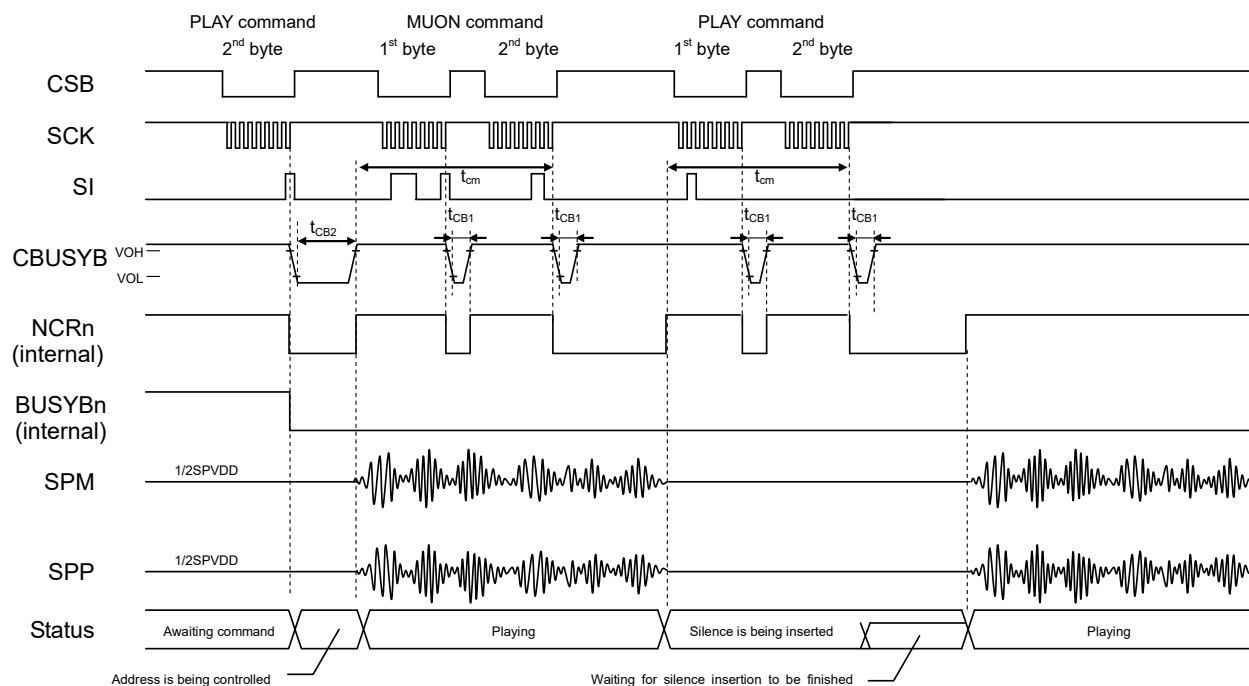

After the PLAY command is input, the CBUSYB signal and NCR signal change to "H" level when the address management of phrase 1 is completed and start playing back. Input the MUON command after the CBUSYB signal changed to "H" level. After the MUON command is received, the LSI is in a state waiting for the end of playback of phrase 1 and the NCR signal remains "L" level until the end of playback.

When the playback of phrase 1 ends, playback of the silence sound starts and the NCR signal changes to "H" level. After the NCR signal of the corresponding channel changes to "H" level, send the PLAY command again to playback the phrase 1. The NCR signal changes to "L" level again after the PLAY command is received and the LSI is in a state waiting for the end of the playback of silence sound.

After ending the playback of silence sound and starting the playback of phrase 1, the NCR signal changes to "H" level and LSI is in state that accepts the next PLAY or MUON command.

The BUSYB signal remains "L" level until the sequence of playback is completed.

When making continuous playbacks, input the MUON/PLAY/START command for the next phrases within 10ms (t_{cm}) after the NCR of the corresponding channel changes to "H" level.

When the playback is not continuous, input the MUON/PLAY/START command for the next phrases after confirming the playback is completed by RDSTAT command, etc.

◆ Repeat playback setting/release timing by SLOOP/CLOOP command

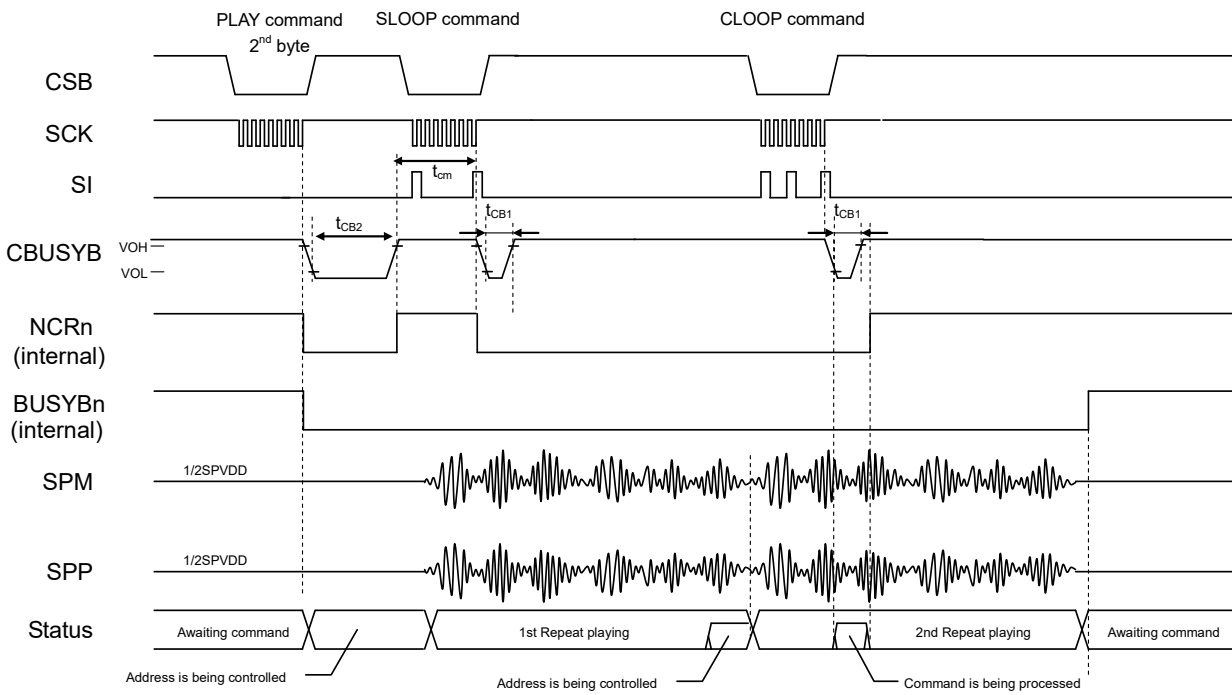

The SLOOP command is valid only during playback. After the PLAY command is input, input the SLOOP command within the specified period (t_{cm}) after the NCR of the corresponding channel becomes "H" level. This enables the SLOOP command and repeats playback. While the repeat playback mode is set, the NCR signal is "L" level.

◆ Change volume timing by CVOL command

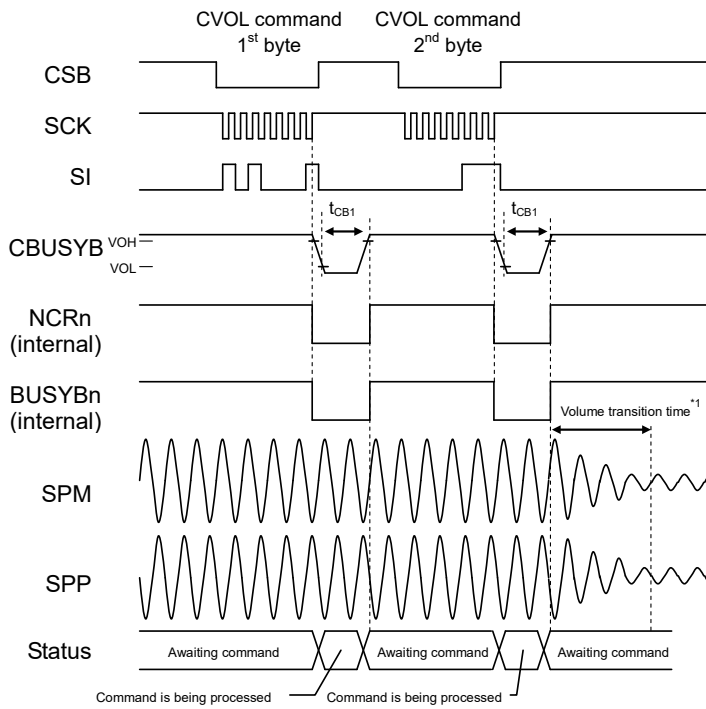

*1 Refer to the "FADE command" for more information on volume-transition time.

◆ RDSTAT command timing

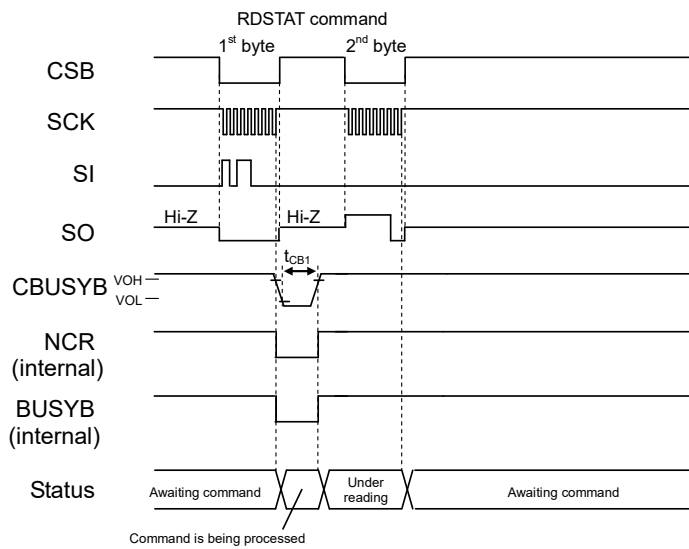

◆ RDVER command timing

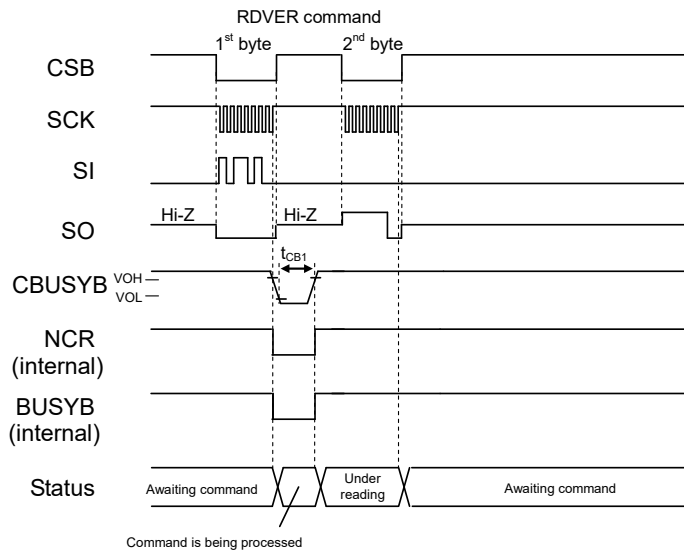

◆ RDERR command timing

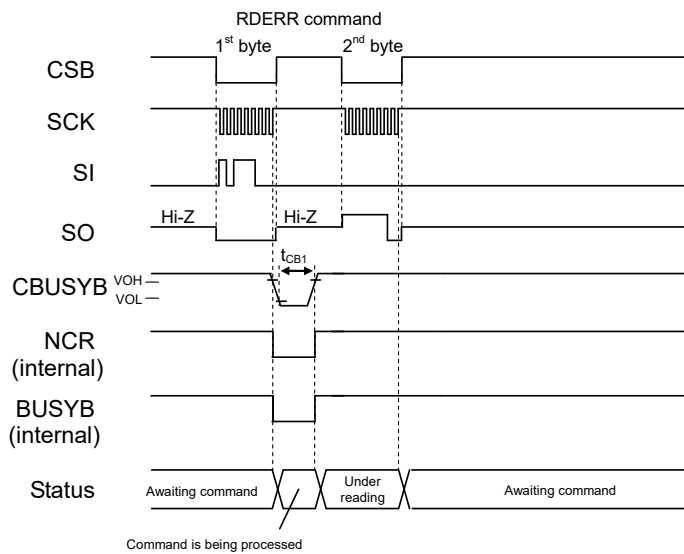

◆ OUTSTAT command timing

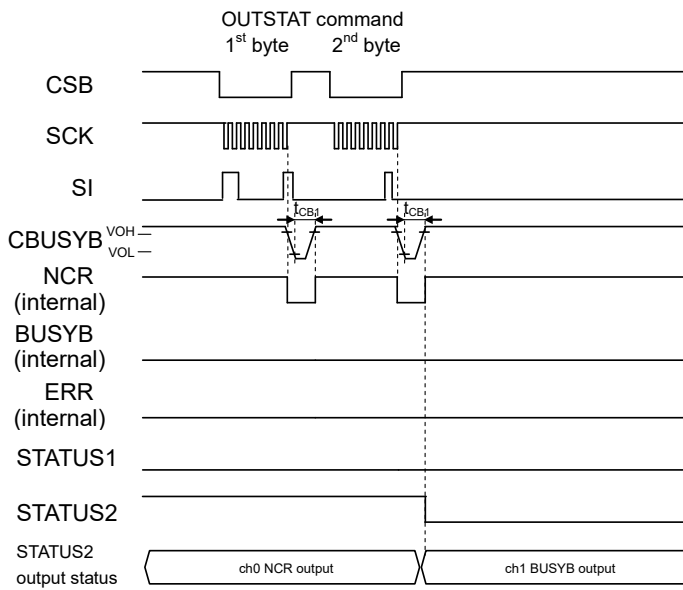

◆ SAFE command timing

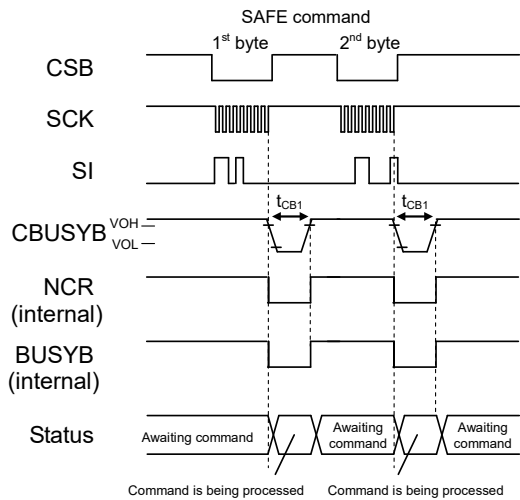

◆ ERRCL command timing

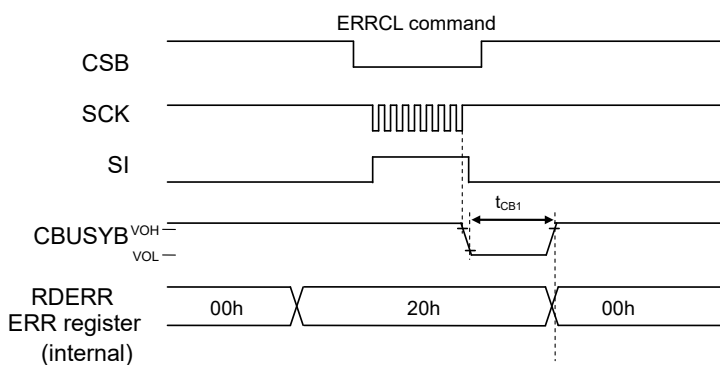

◆ Setting timing of playback phrases by FADR2 command

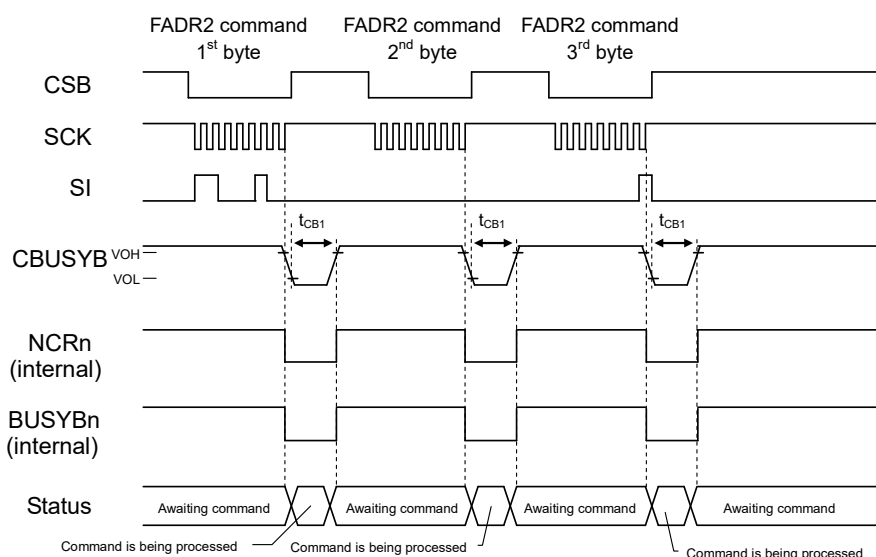

◆ Playback start timing by PLAY2 command

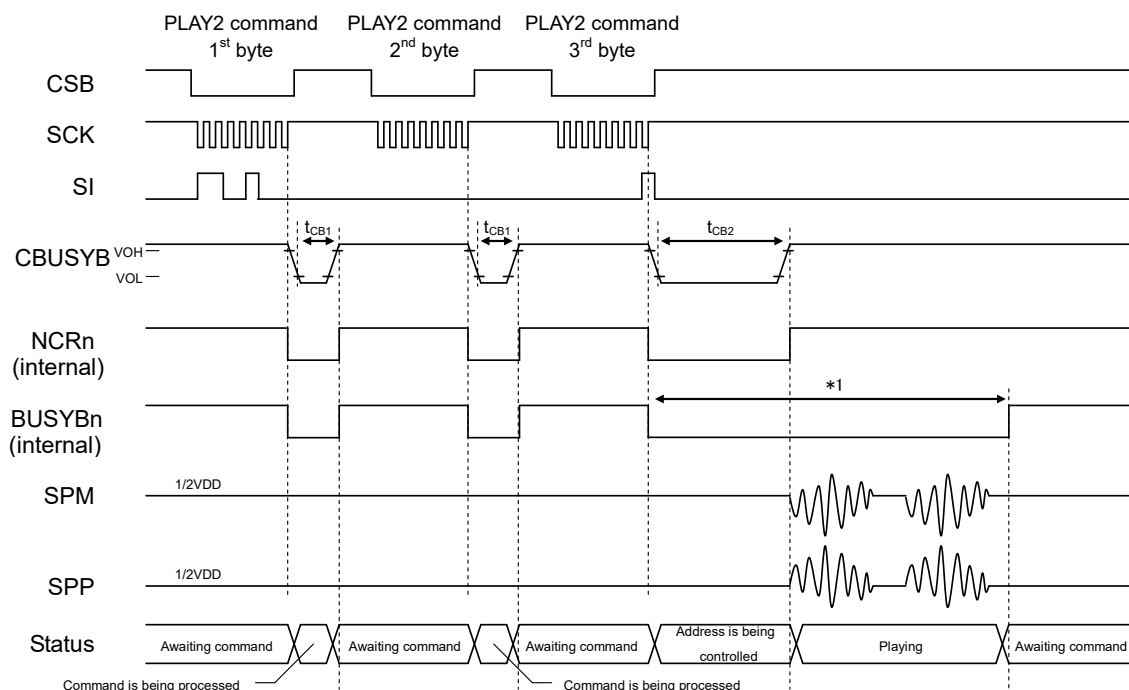

When the first byte of the PLAY command is input, the 2nd byte waits for input after the command processing time (t_{CB1}), and when the 2nd byte is input, the 3rd byte waits for input after the command processing time (t_{CB1}). When the third byte is entered, the address data of the phrase to be played after the command processing time (t_{CB2}) is read from the flash memory. When the phrase address data is read, the specified phrase is played back, and when playback is completed, the BUSYB signal of the playback channel becomes "H" level.

The NCR signal goes to the "L" level during playback preparation, and goes to the "H" level when playback preparation is completed and playback starts. When the NCR signal of the playback channel becomes "H" level, the PLAY command of the next phrase to be played can be accepted.

*1 The length of the "L" interval in the BUSYB_n is (t_{CB2} + sound production time).

◆ Change volume timing by PAN command

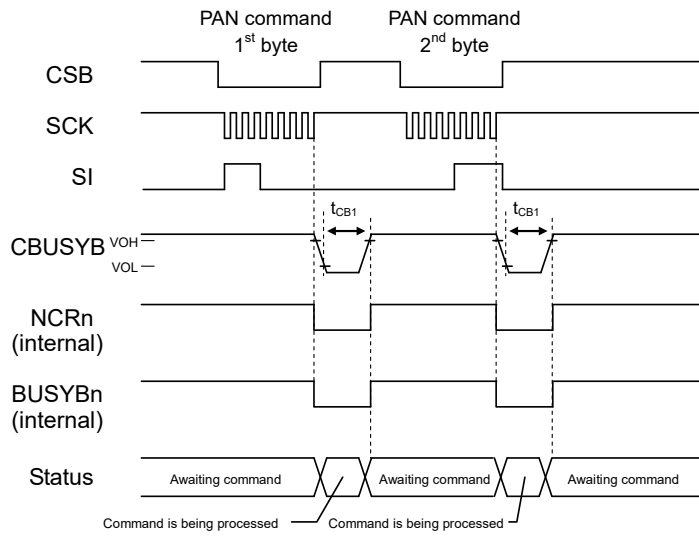

◆ SAICH command timing

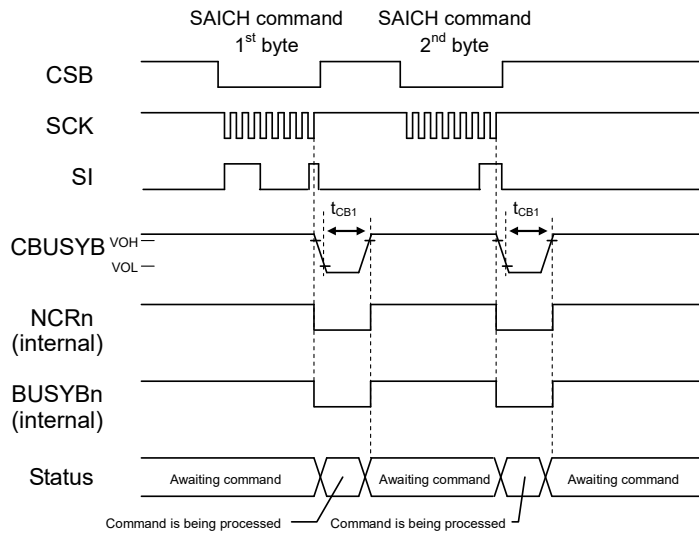

◆ SAICON command timing

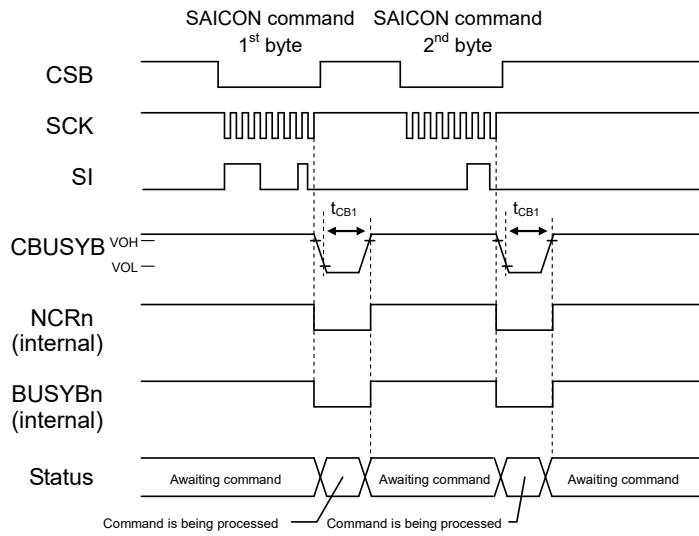

◆ SAITCON command timing

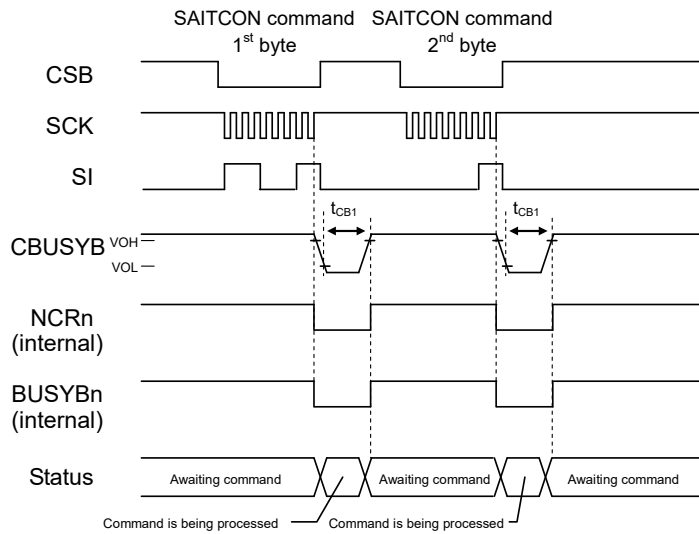

◆ SAIRCON command timing

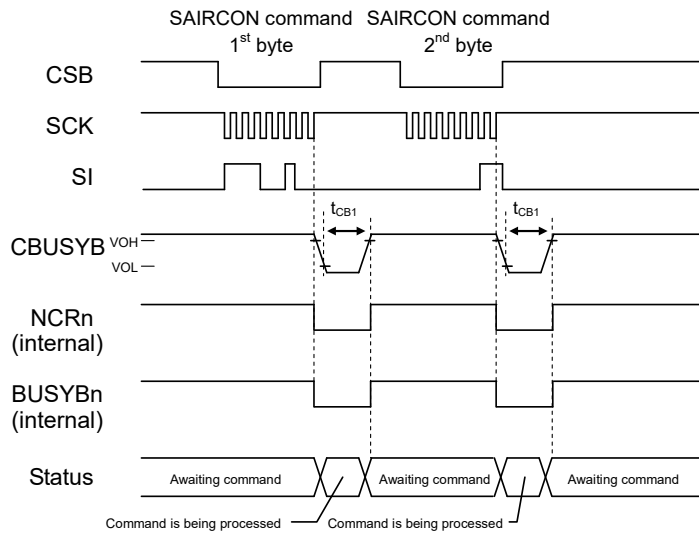

◆ SAIMOD command timing

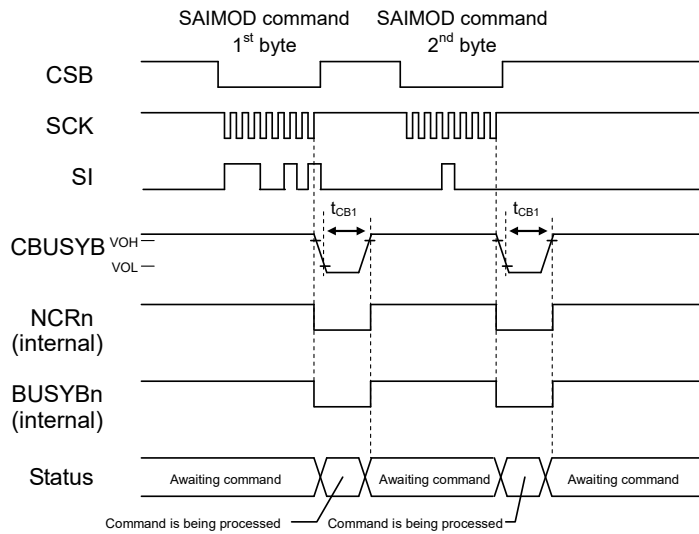

◆ Setting timing by playback sound error detection command

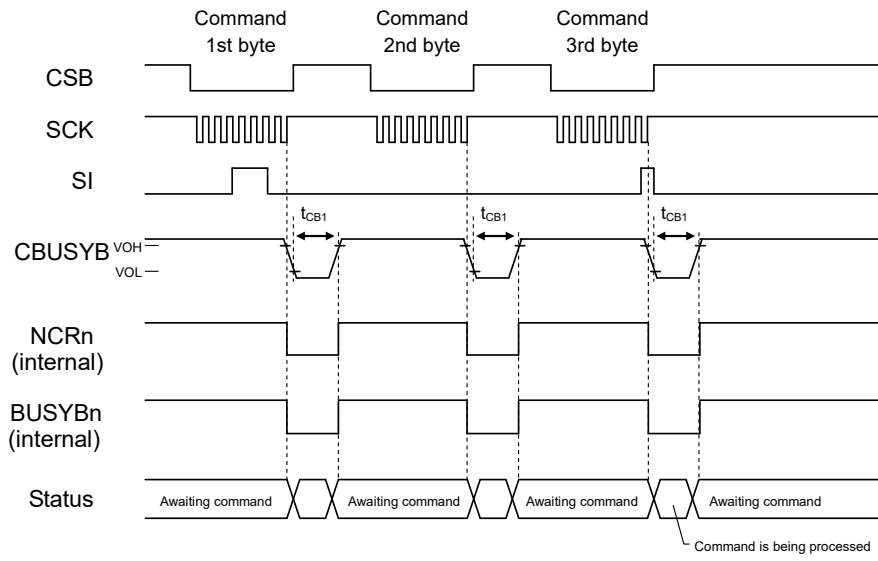

● I²C Interface (Slave)

◆ I²C Interface Timing

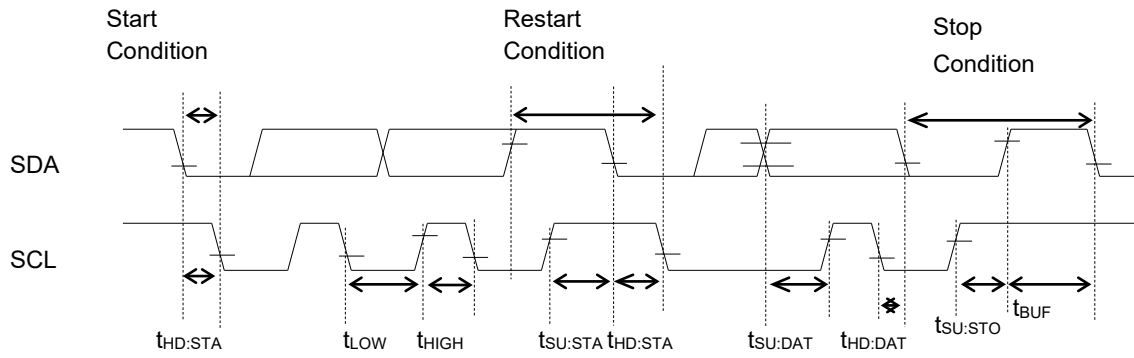

◆ Power-up timing

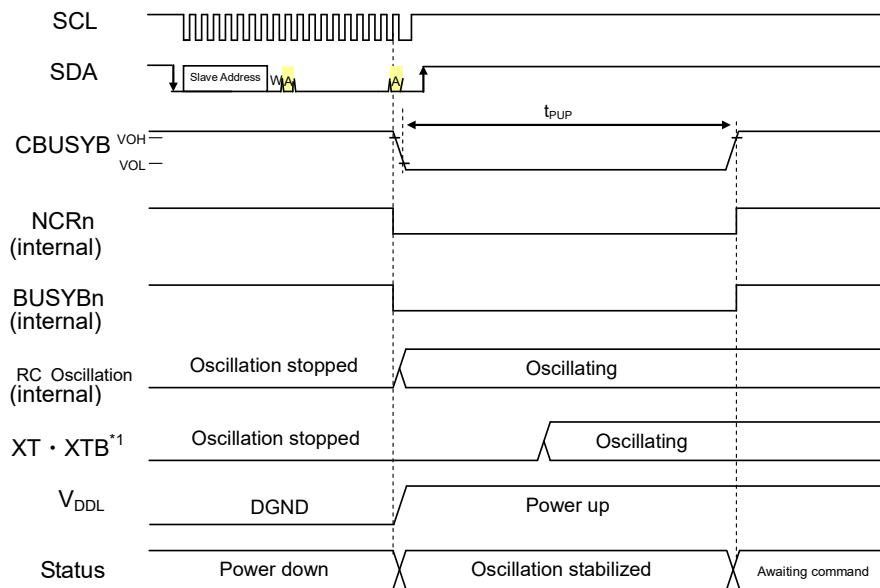

*1 When using a crystal or ceramic resonator

◆ Power-down timing

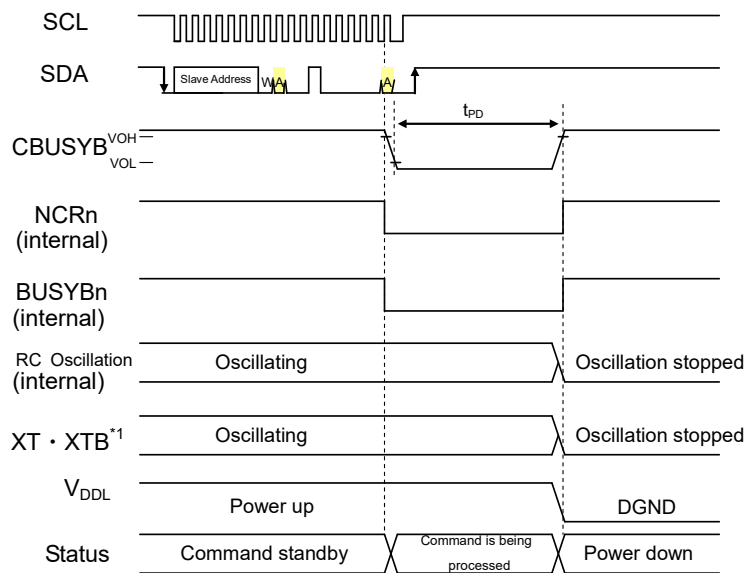

*1 When using a crystal or ceramic resonator

◆ Speaker amplifier power-up timing (DAMP bit = "0", AEN1 bit = "0", AEN0 bit = "0" → "1")

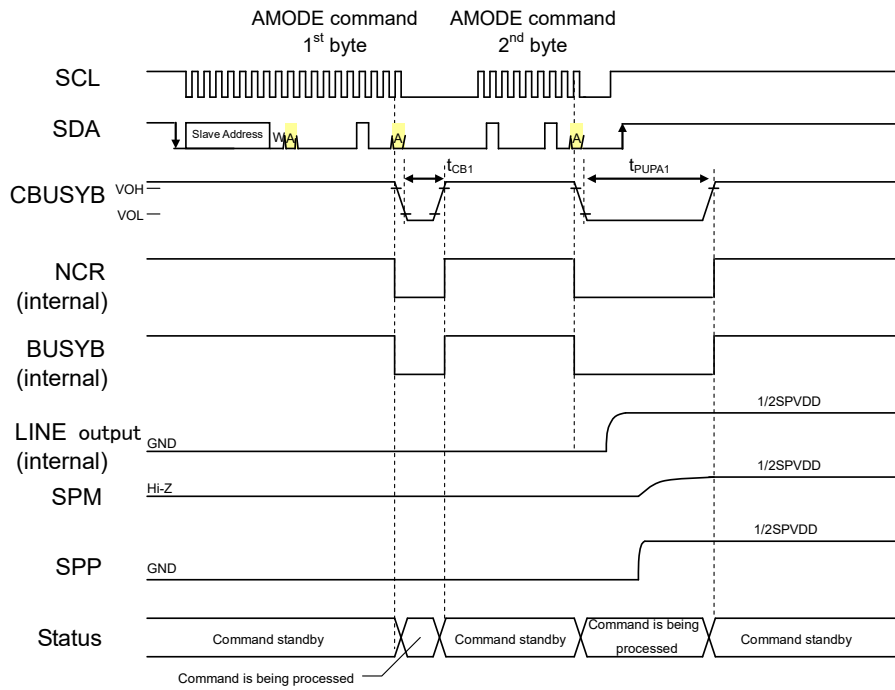

◆ Line amplifier power-up timing (DAMP bit = "0", POP bit = "1", AEN1 bit = "0" → "1", AEN0 bit = "0")

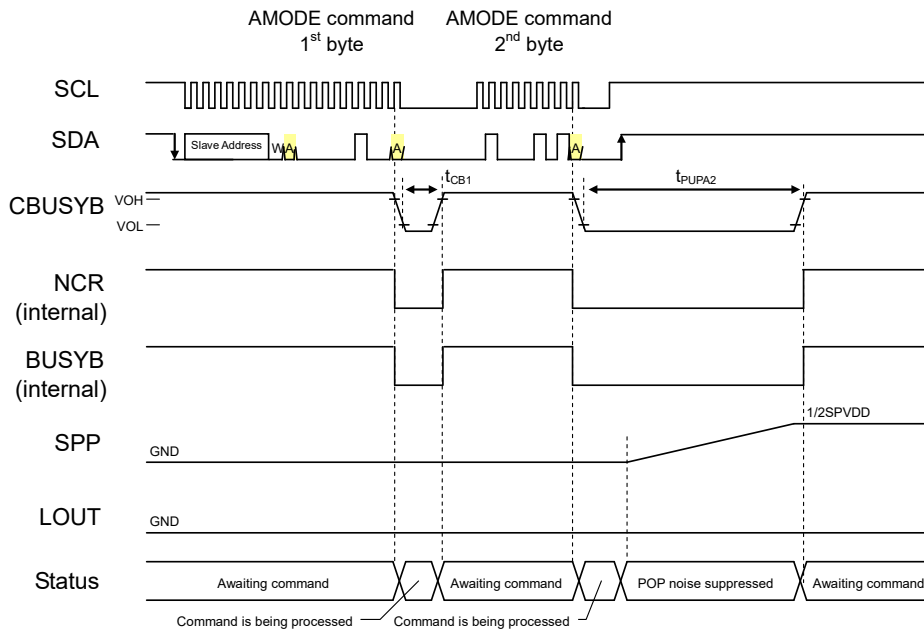

◆ Line amplifier power-up timing (DAMP bit = "0", POP bit = "0", AEN1 bit = "0" → "1", AEN0 bit = "0")

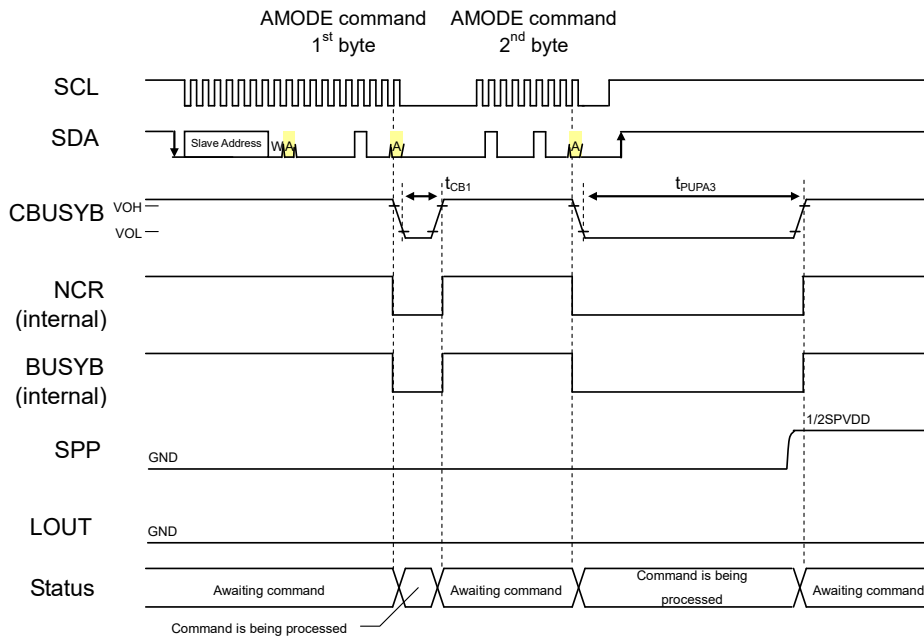

◆ Line amplifier power-up timing (DAMP bit = "0", POP bit = "1", AEN1 bit = "0" → "1", AEN0 bit = "0" → "1")

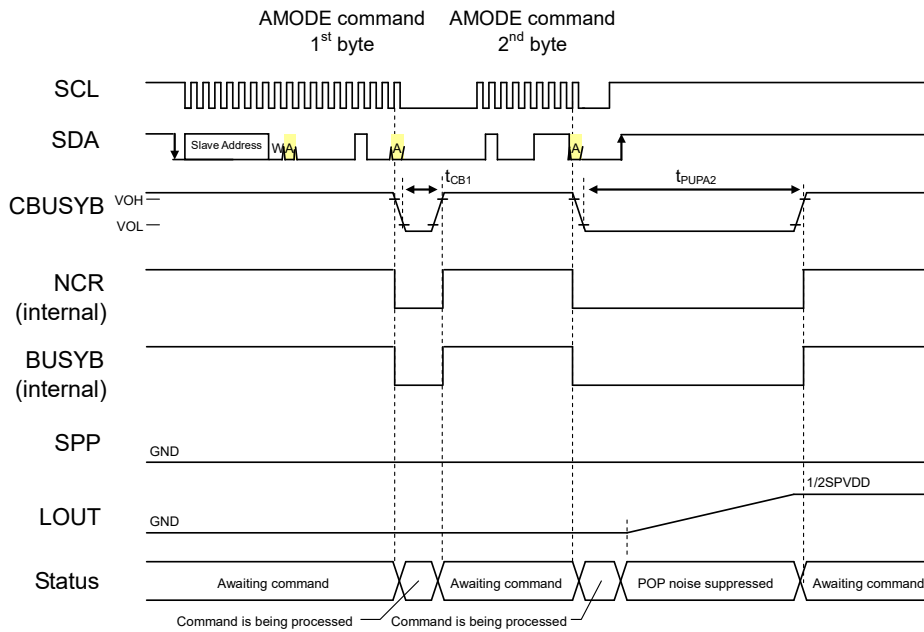

◆ Line amplifier power-up timing (DAMP bit = "0", POP bit = "0", AEN1 bit = "0" → "1", AEN0 bit = "0" → "1")

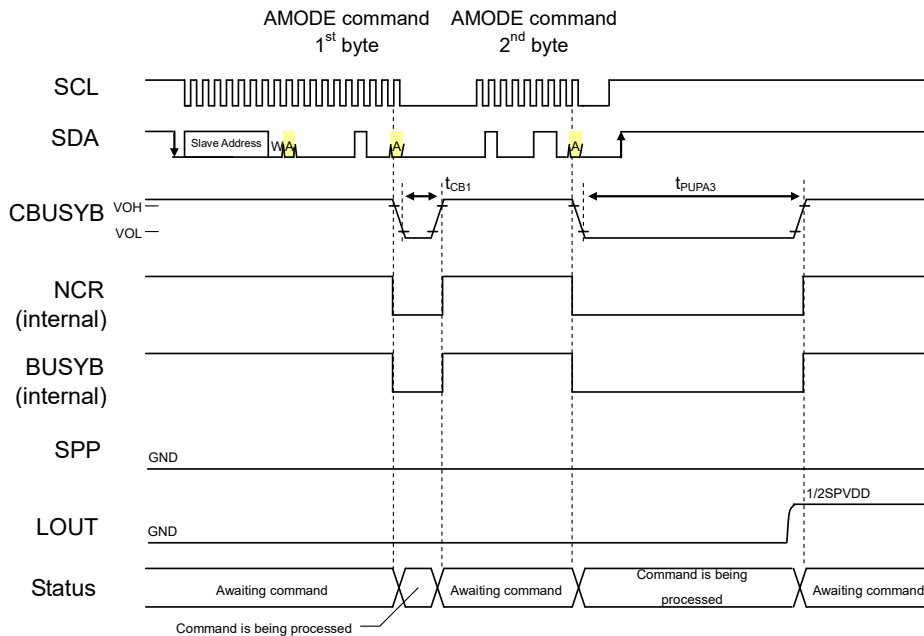

◆ Speaker amplifier power-down timing (DAMP bit = "0", AEN1 bit = "0", AEN0 bit = "1" → "0")

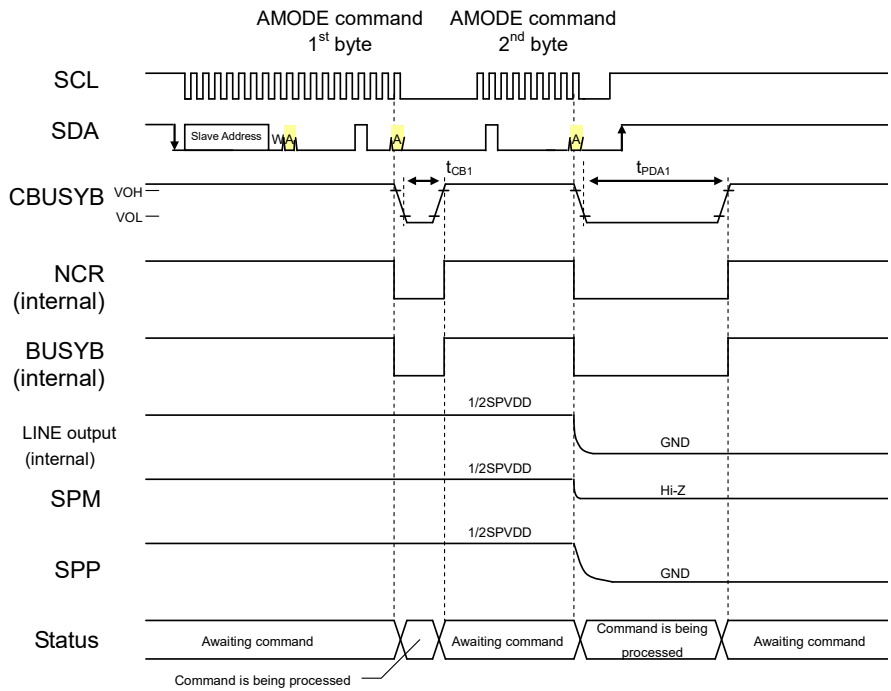

◆ Line amplifier power-down timing (DAMP bit = "0", POP bit = "1", AEN1 bit = "1" → "0", AEN0 bit = "0")

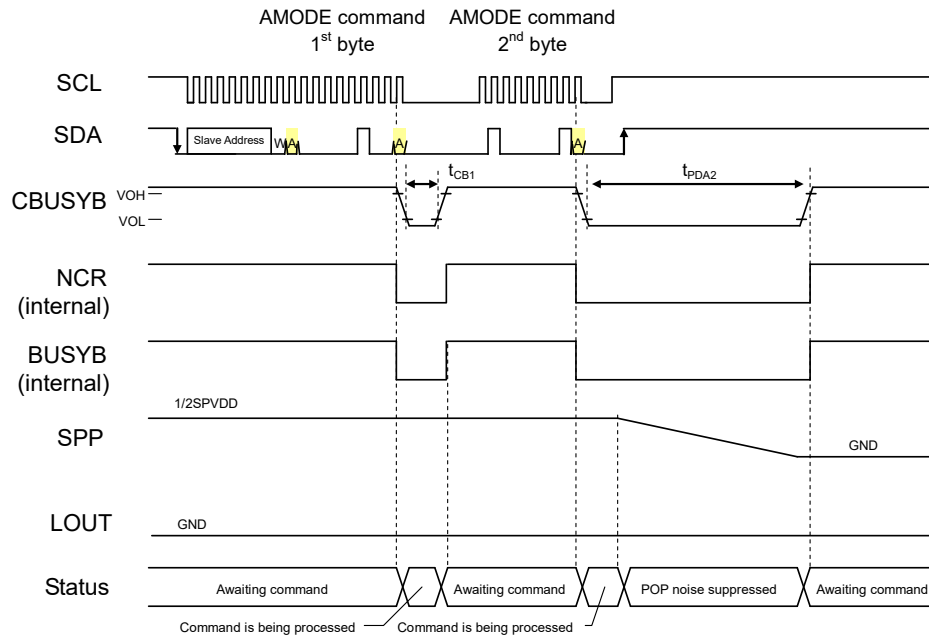

◆ Line amplifier power-down timing (DAMP bit = "0", POP bit = "0", AEN1 bit = "1" → "0", AEN0 bit = "0")

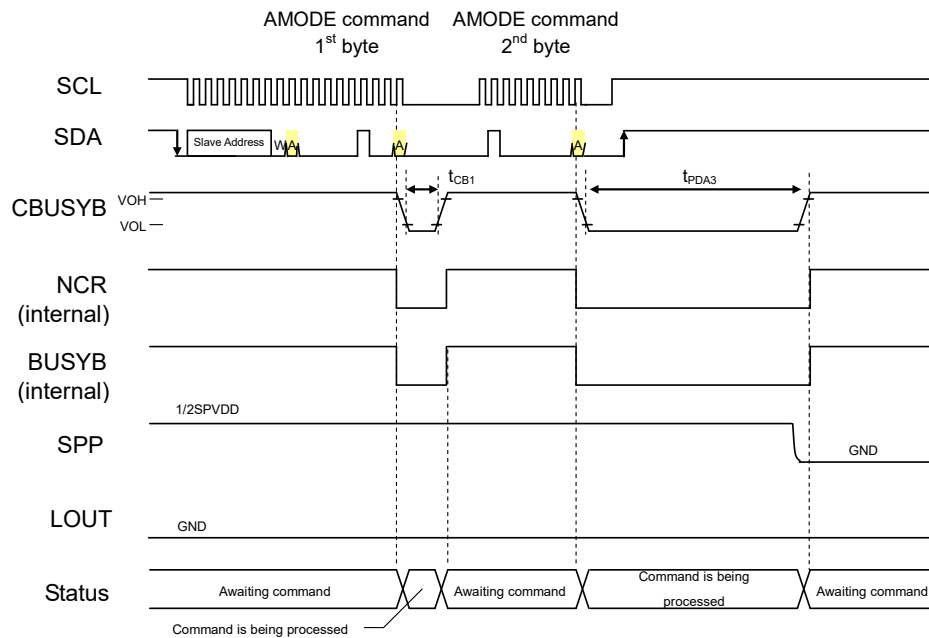

◆ Line amplifier power-down timing (DAMP bit = "0", POP bit = "1", AEN1 bit = "1" → "0", AEN0 bit = "1" → "0")

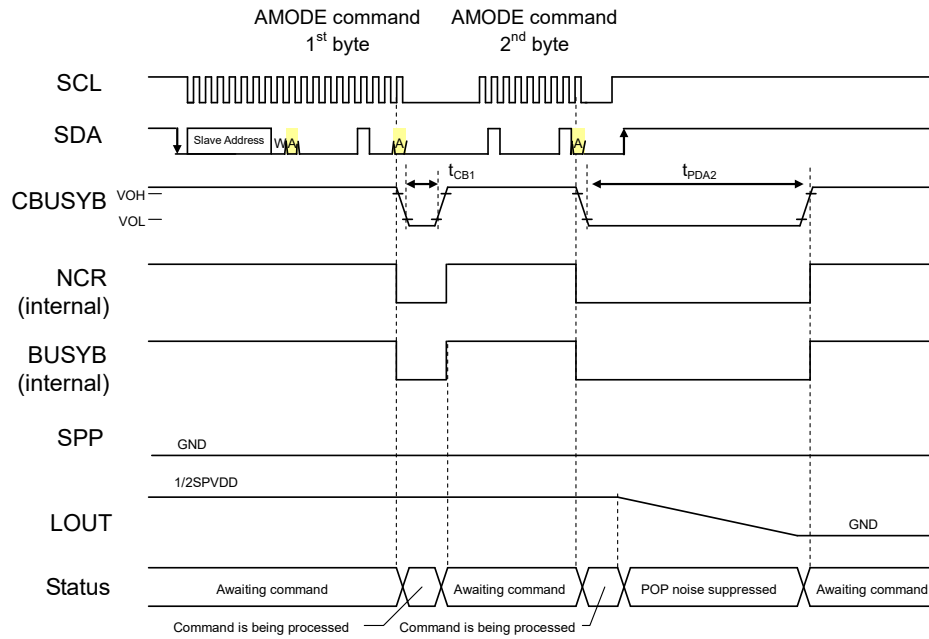

◆ Line amplifier power-down timing (DAMP bit = "0", POP bit = "0", AEN1 bit = "1" → "0", AEN0 bit = "1" → "0")

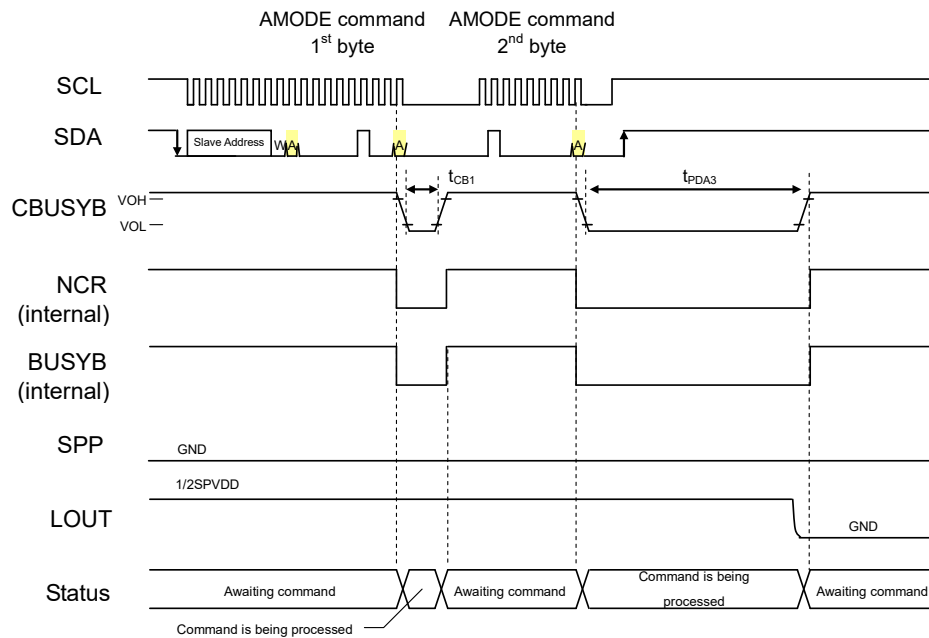

◆ WDTCL command timing

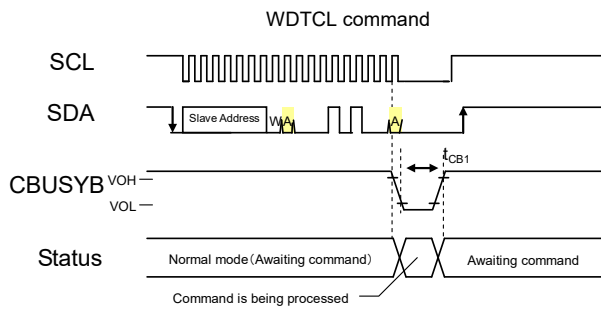

◆ Change volume timing by AVOL command

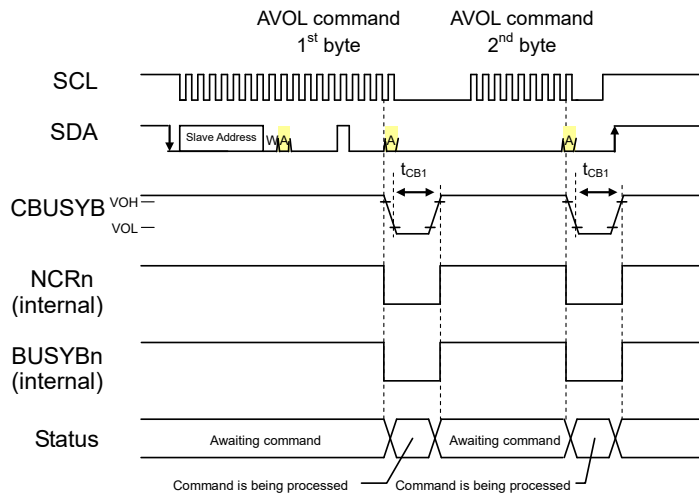

Speaker amplifier volume setting by AVOL commands is valid only when Class AB speaker amplifier is used. When a Class D speaker amplifier is used, the setting value is ignored and +0.0dB is selected.

◆ FADE command timing

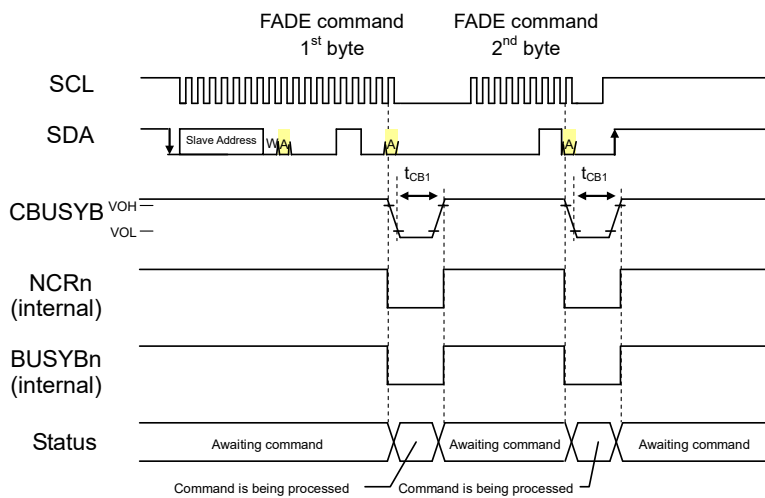

◆ Setting playback phrases using FADR command

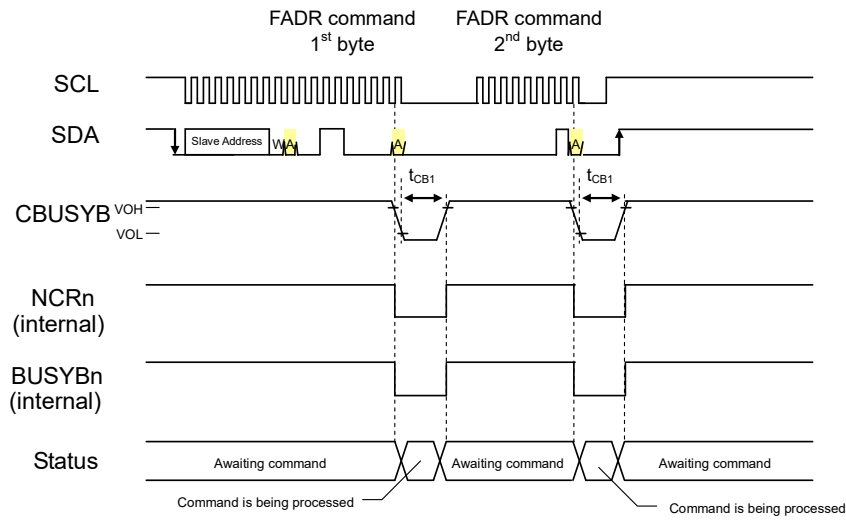

◆ Playback start timing by PLAY command

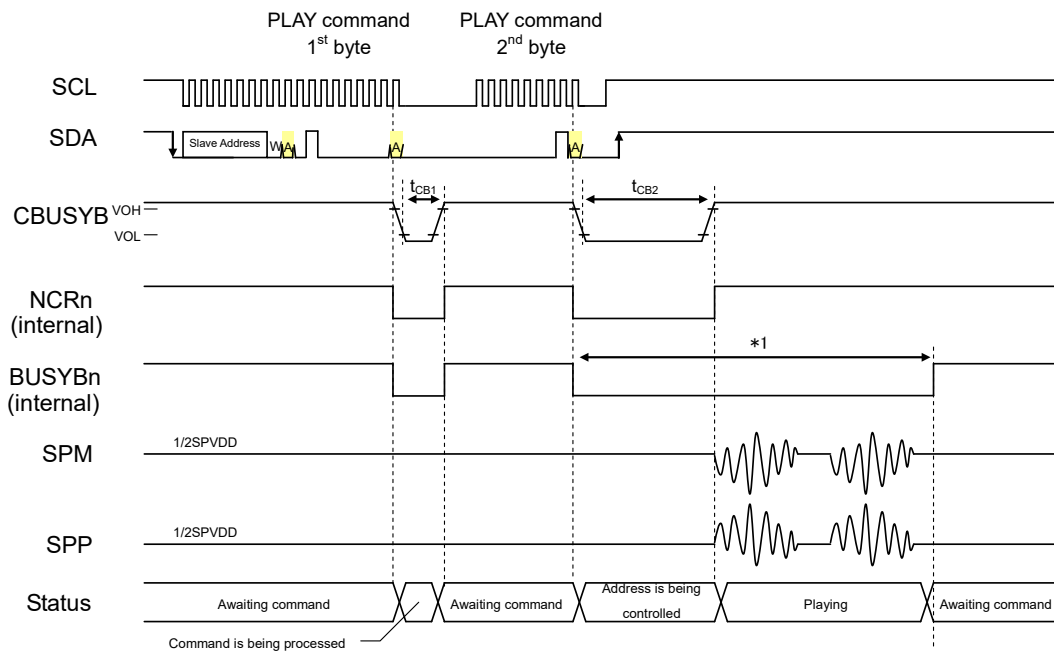

When the first byte of the PLAY command is input, the device waits for the input of the second byte after the command processing time (t_{CB1}). When the second byte is entered, the address data of the phrase to be played after the command processing time (t_{CB2}) is read from the flash memory.

When the phrase address data is read, the specified phrase is played back, and when playback is completed, the BUSYB signal of the playback channel becomes "H" level.

The NCR signal goes to the "L" level during playback preparation, and goes to the "H" level when playback preparation is completed and playback starts. When the NCR signal of the playback channel becomes "H" level, the PLAY command of the next phrase to be played can be accepted.

*1 The length of the "L" interval in the BUSYBn is (t_{CB2} + sound production time).

◆ Continuous playback timing by PLAY command

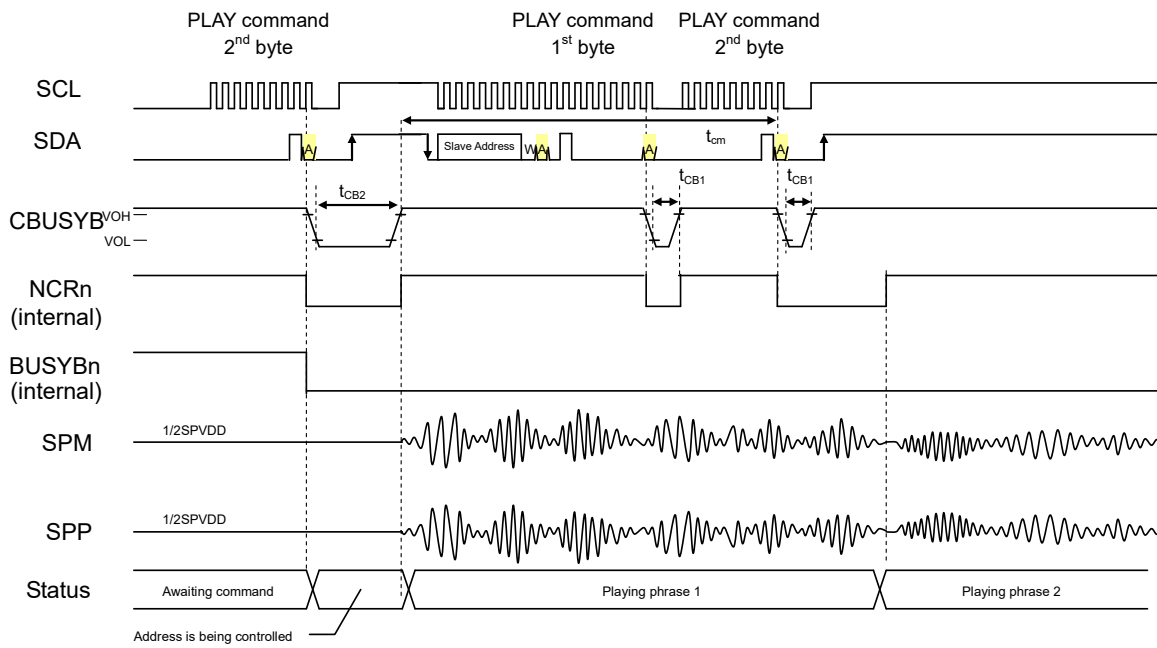

When making continuous playbacks, input the PLAY command for the next phrases within the specified time period (t_{cm}) after the NCR of the corresponding channel changes to "H" level, so that the LSI plays back the next phrases without silence sounds after the current phrase playback ends.

When the playback is not continuous, input the PLAY command for the next phrases after confirming the playback is completed by RDSTAT command, etc.

◆ Playback start timing by START command

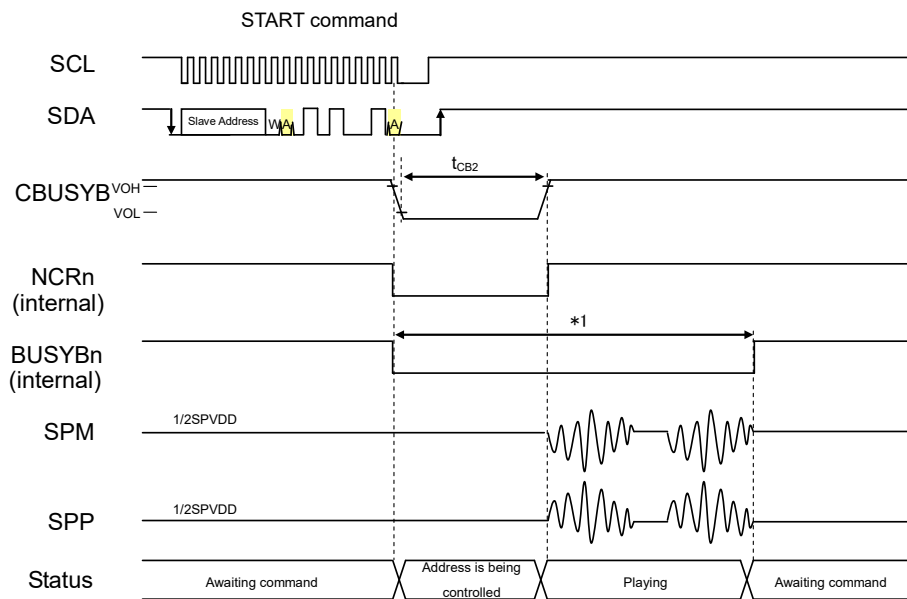

When the START command is input, the address data of the phrase to be played after the command processing time (t_{CB2}) is read from the flash memory. When the phrase address data is read, the specified phrase is played back, and when playback is completed, the BUSYB signal of the playback channel becomes "H" level.

The NCR signal goes to the "L" level during playback preparation, and goes to the "H" level when playback preparation is completed and playback starts. When the NCR signal of the playback channel becomes "H" level, the START command of the next phrase to be played can be accepted.

*1 The length of the "L" interval in the BUSYBn is (t_{CB2} + sound production time).

◆ Continuous playback timing by START command

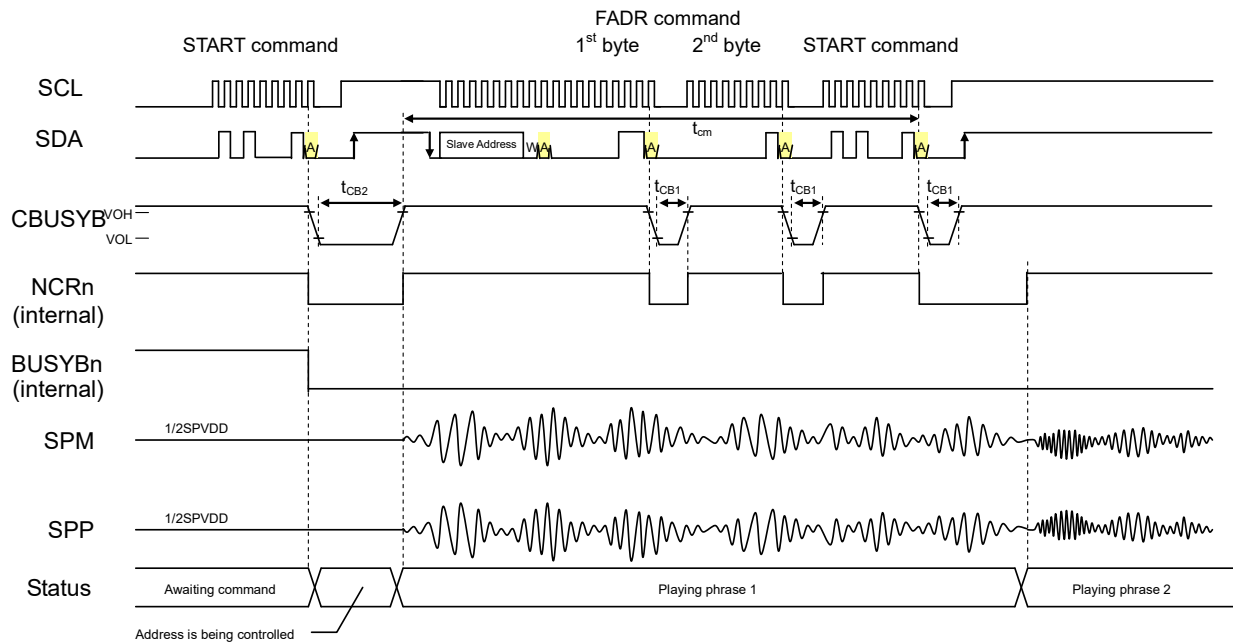

When making continuous playbacks, input the START command for the next phrases within the specified time period (t_{cm}) after the NCR of the corresponding channel changes to "H" level, so that the LSI plays back the next phrases without silence sounds after the current phrase playback ends.

When the playback is not continuous, input the START command for the next phrases after confirming the playback is completed by RDSTAT command, etc.

◆ STOP command (when the FAD bit is "L")

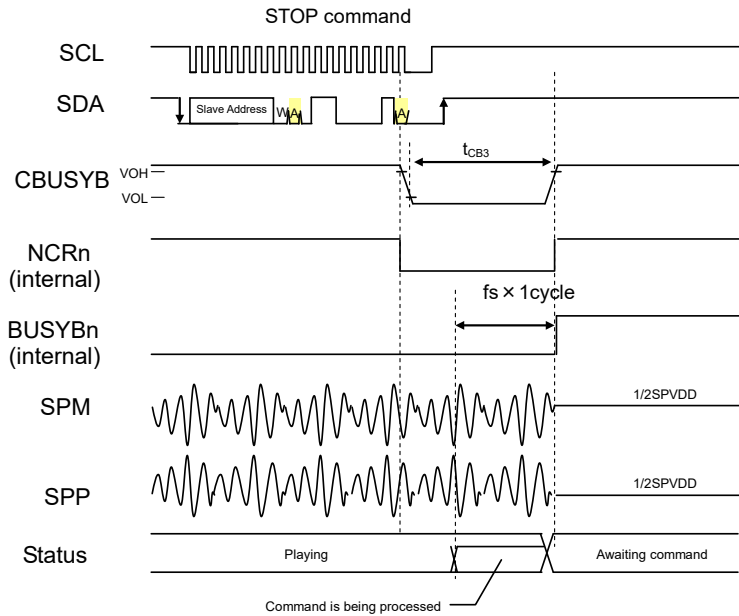

◆ STOP command (when the FAD bit is "H")

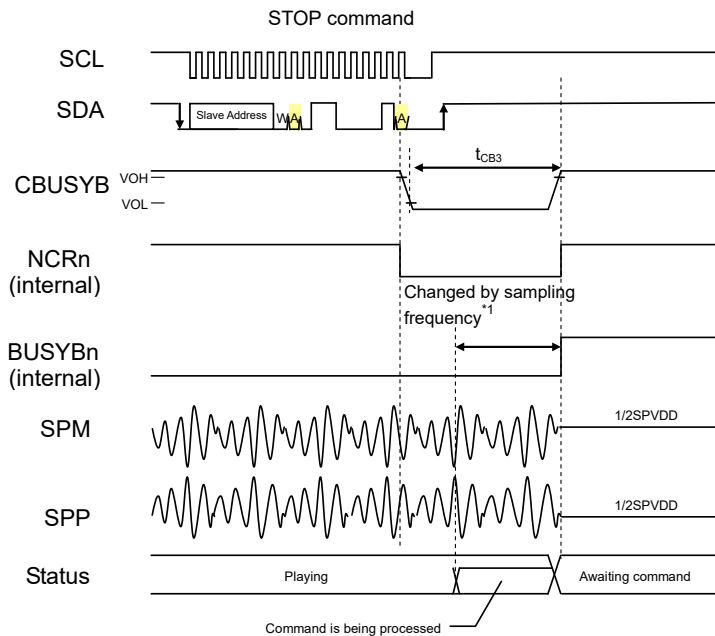

*1 The duration of the BUSYBn varies depending on the sampling frequency groups.

At 10.7/21.3kHz	: Approx. 3ms
At 6.4/12.8/25.6kHz	: Approx. 5ms
At 8.0/16.0/32.0kHz	: Approx. 4ms
At 11.025/22.05/44.1kHz	: Approx. 2.9ms
At 12.0/24.0/48.0kHz	: Approx. 2.7ms

◆ Playback start timing by MUON command

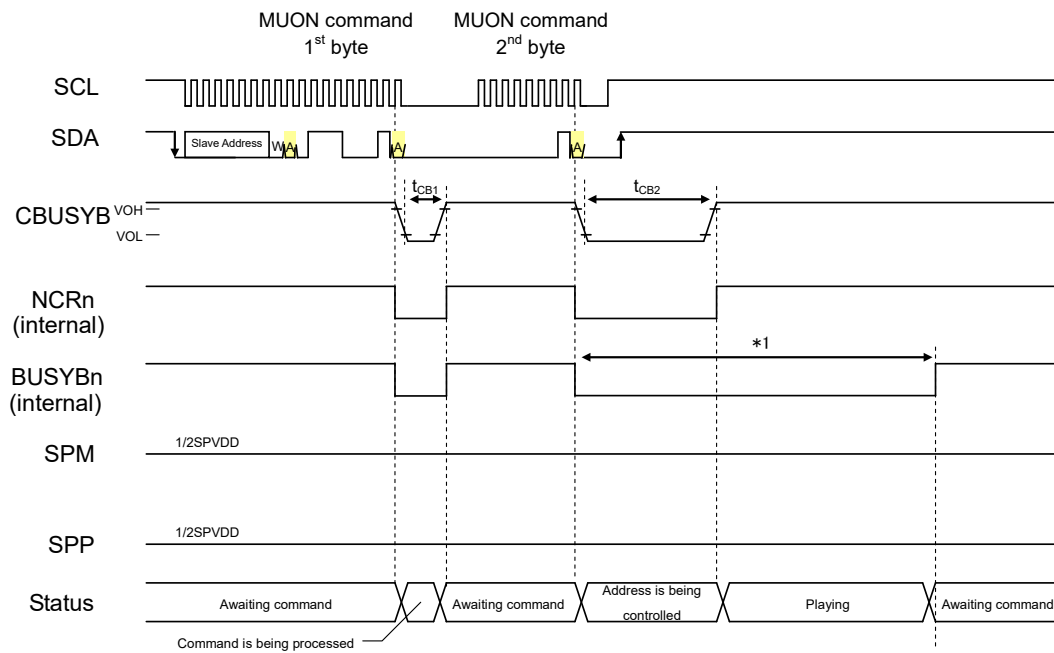

When the first byte of the MUON command is input, the device waits for the input of the second byte after the command processing time (t_{CB1}). When the second byte is entered, the silence time is calculated after the command processing time (t_{CB2}). When the calculation of the silence duration is completed, the calculated silence is played back, and when the playback is completed, the BUSYB signals of the playback channels become "H" level.

The NCR signal becomes "L" level during playback preparation, and becomes "H" level when playback preparation is completed and playback starts. When the NCR signal of the playback channel becomes "H" level, the PLAY command of the next phrase to be played can be accepted.

*1 The length of the "L" interval of the BUSYBn is (t_{CB2} + silence playback time).

◆ Continuous playback timing by MUON command

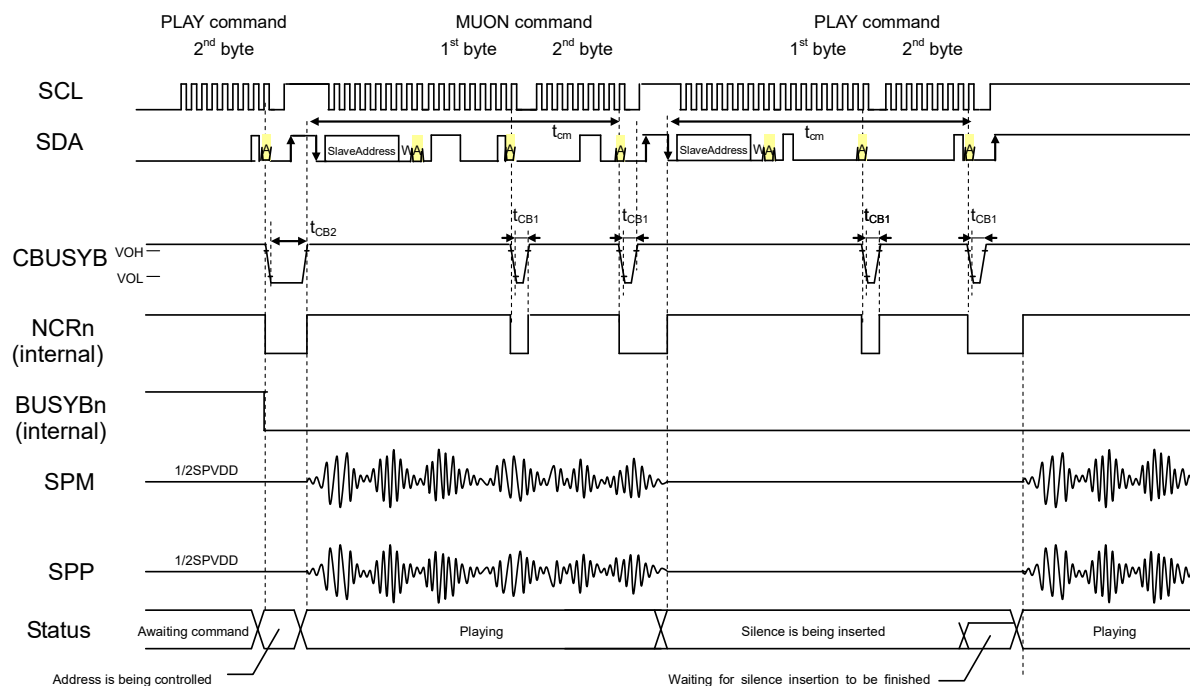

After the PLAY command is input, the CBUSYB signal and NCR signal change to "H" level when the address management of phrase 1 is completed and start playing back. Input the MUON command after the CBUSYB signal changed to "H" level. After the MUON command is received, the LSI is in a state waiting for the end of playback of phrase 1 and the NCR signal remains "L" level until the end of playback.

When the playback of phrase 1 ends, playback of the silence sound starts and the NCR signal changes to "H" level. After the NCR signal of the corresponding channel changes to "H" level, send the PLAY command again to playback the phrase 1. The NCR signal changes to "L" level again after the PLAY command is received and the LSI is in a state waiting for the end of the playback of silence sound.

After ending the playback of silence sound and starting the playback of phrase 1, the NCR signal changes to "H" level and LSI is in state that accepts the next PLAY or MUON command.

The BUSYB signal remains "L" level until the sequence of playback is completed.

When making continuous playbacks, input the MUON/PLAY/START command for the next phrases within 10ms (t_{cm}) after the NCR of the corresponding channel changes to "H" level.

When the playback is not continuous, input the MUON/PLAY/START command for the next phrases after confirming the playback is completed by RDSTAT command, etc.

◆ Repeat playback setting/release timing by SLOOP/CLOOP command

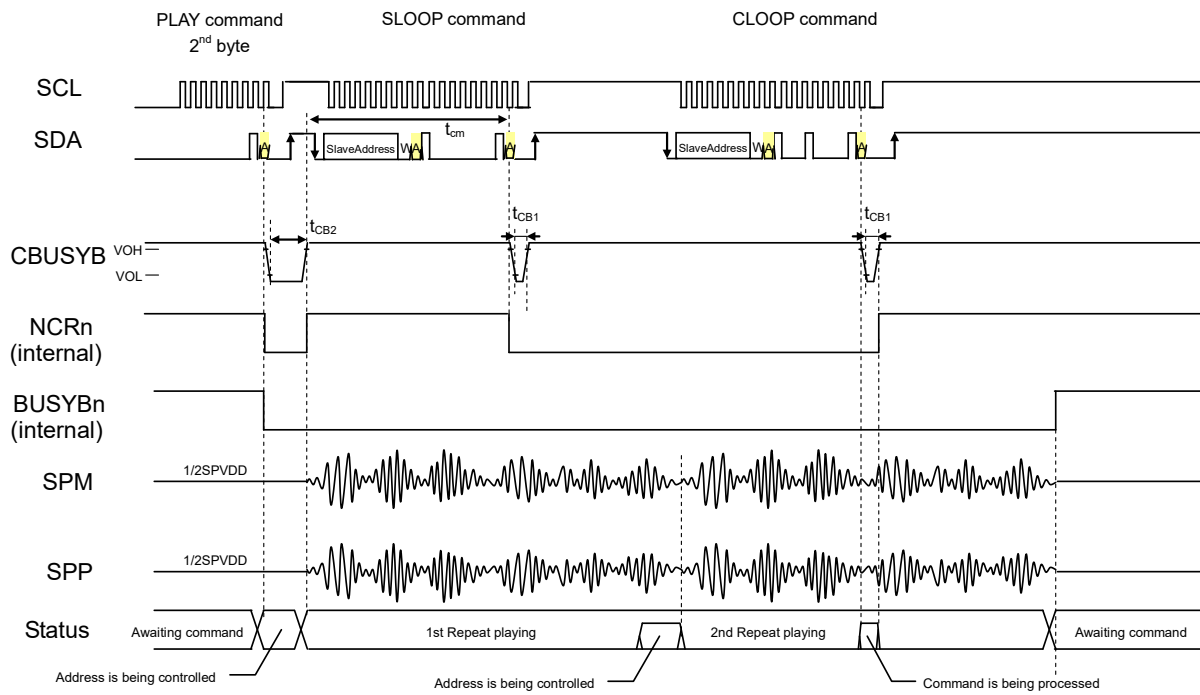

The SLOOP command is valid only during playback. After the PLAY command is input, input the SLOOP command within the specified period (t_{cm}) after the NCR of the corresponding channel becomes "H" level. This enables the SLOOP command and repeats playback. While the repeat playback mode is set, the NCR signal is "L" level.

◆ Change volume timing by CVOL command

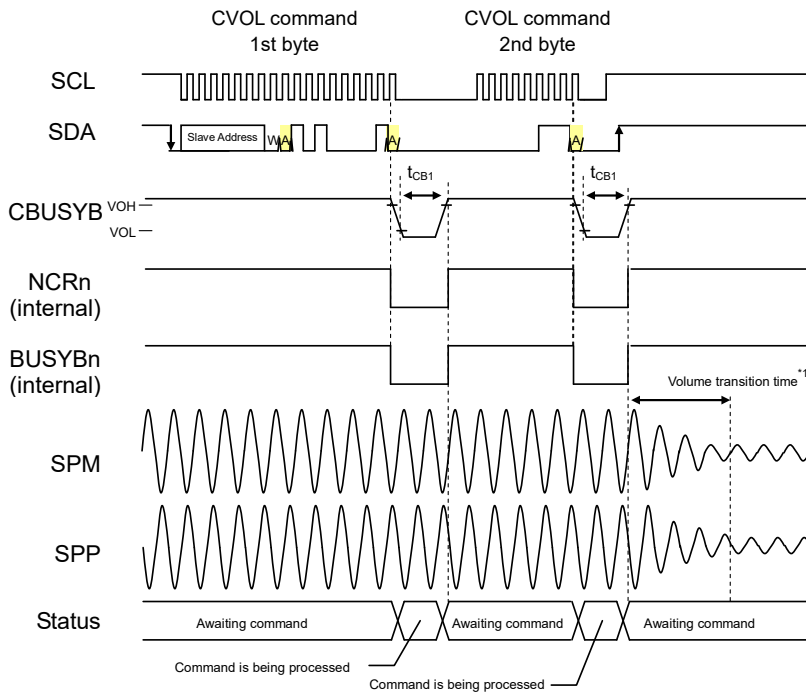

*1 Refer to the "FADE command" for more information on volume-transition time.

◆ RDSTAT command timing

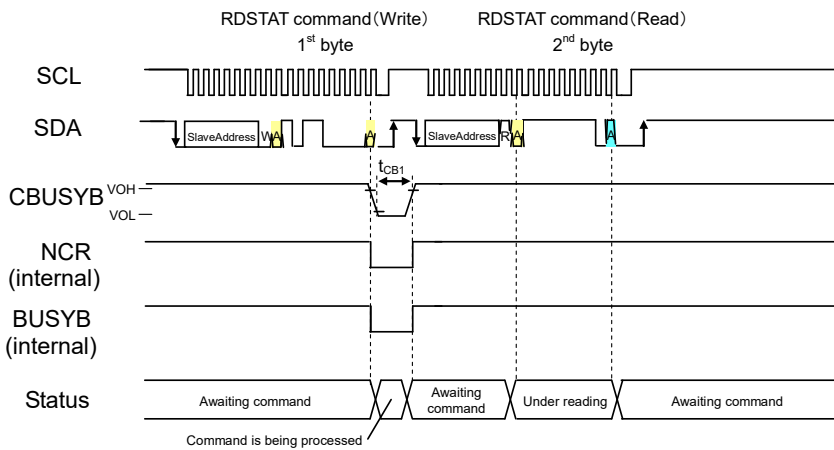

◆ RDVER command timing

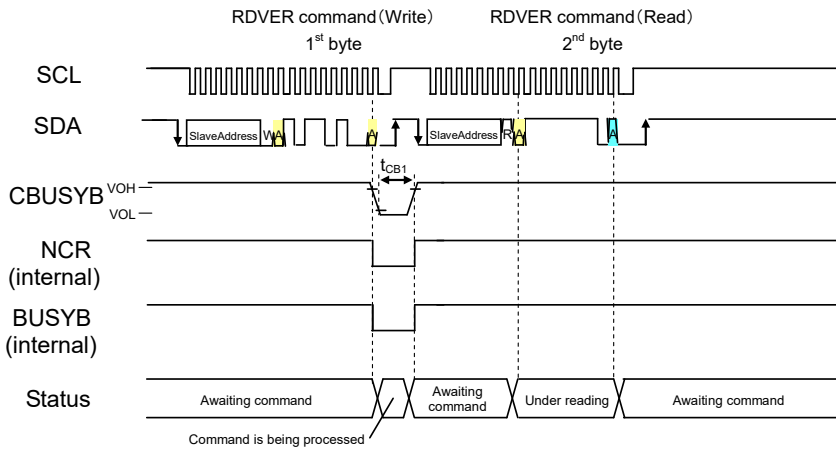

◆ RDERR command timing

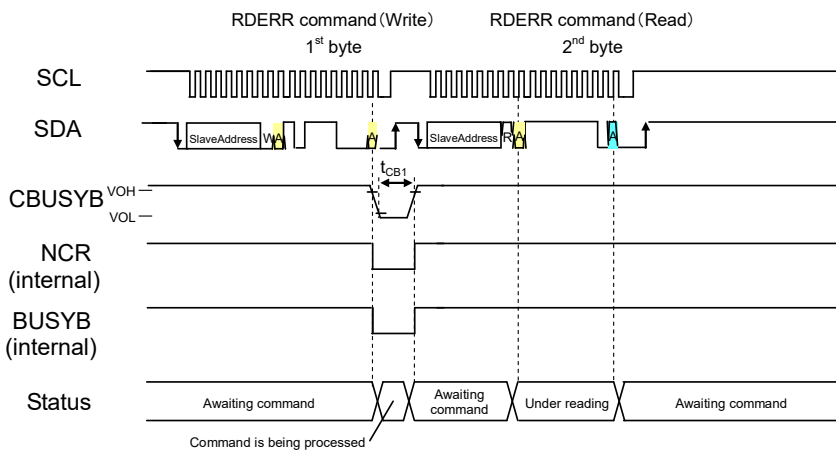

◆ OUTSTAT command timing

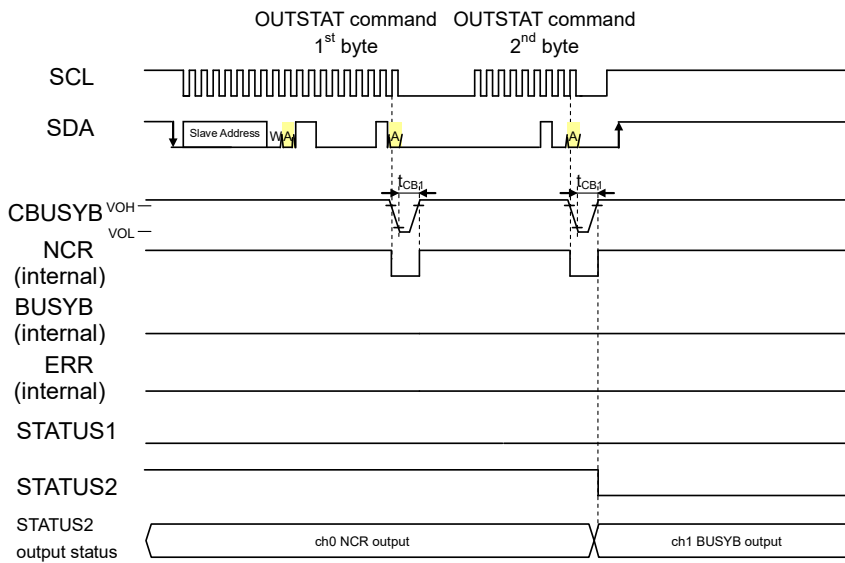

◆ SAFE command timing

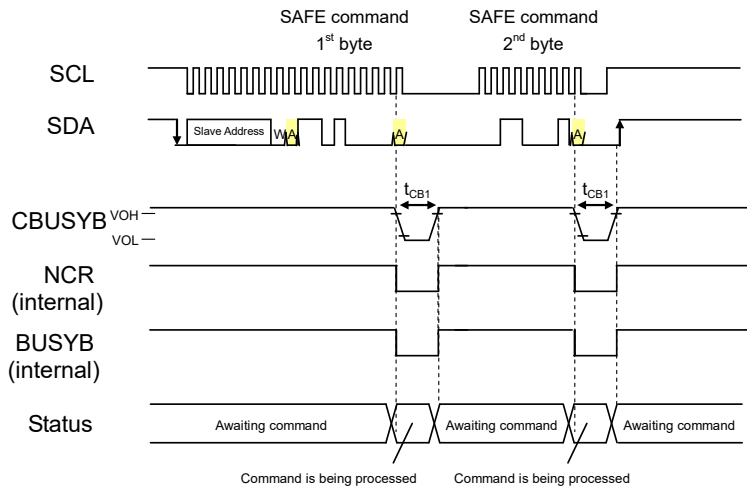

◆ ERRCL command timing

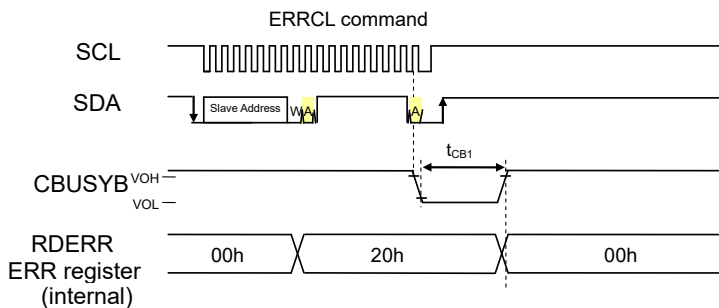

◆ Setting timing of playback phrases by FADR2 command

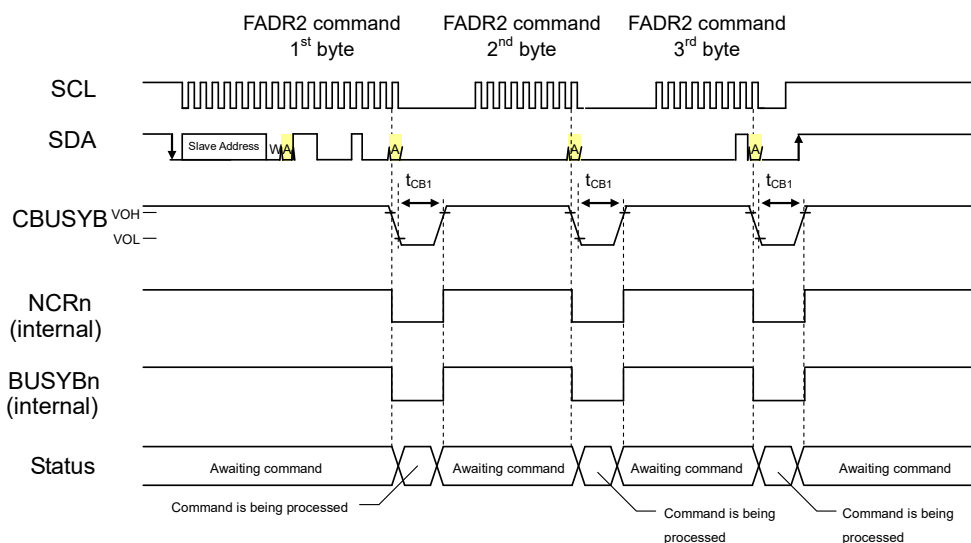

◆ Playback start timing by PLAY2 command

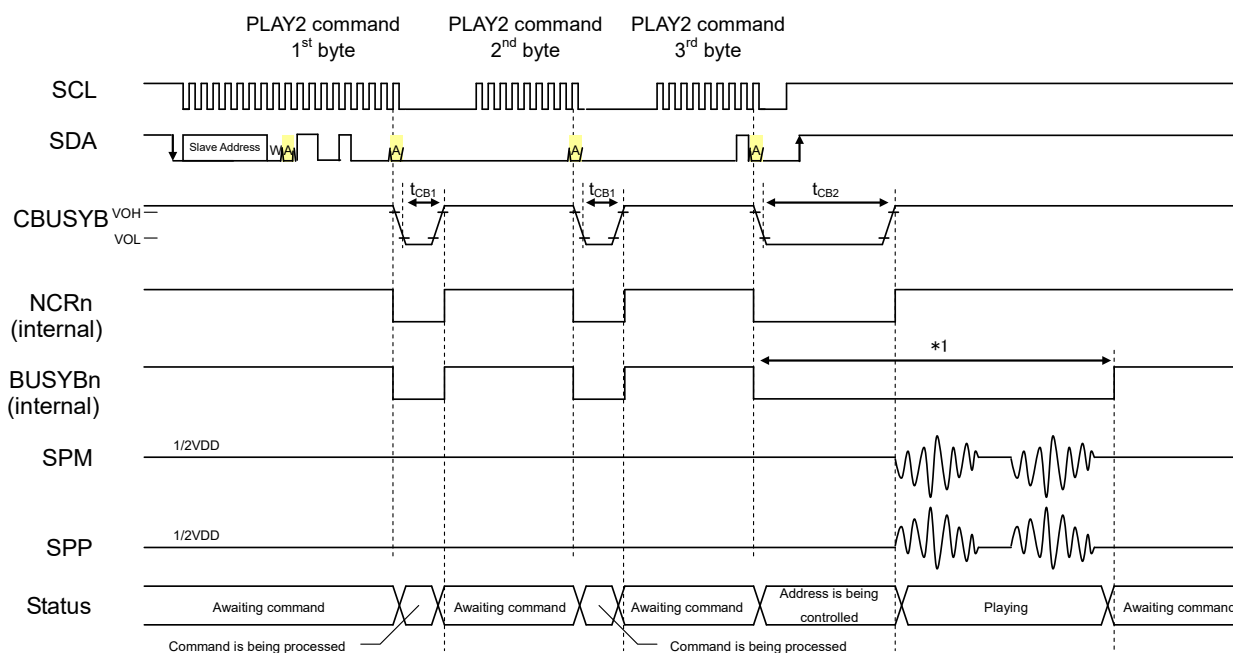

When the first byte of the PLAY command is input, the 2nd byte waits for input after the command processing time (t_{CB1}), and when the 2nd byte is input, the 3rd byte waits for input after the command processing time (t_{CB1}). When the third byte is entered, the address data of the phrase to be played after the command processing time (t_{CB2}) is read from the flash memory. When the phrase address data is read, the specified phrase is played back, and when playback is completed, the BUSYB signal of the playback channel becomes "H" level.

The NCR signal goes to the "L" level during playback preparation, and goes to the "H" level when playback preparation is completed and playback starts. When the NCR signal of the playback channel becomes "H" level, the PLAY command of the next phrase to be played can be accepted.

*1 The length of the "L" interval in the BUSYB_n is (t_{CB2} + sound production time).

◆ Change volume timing by PAN command

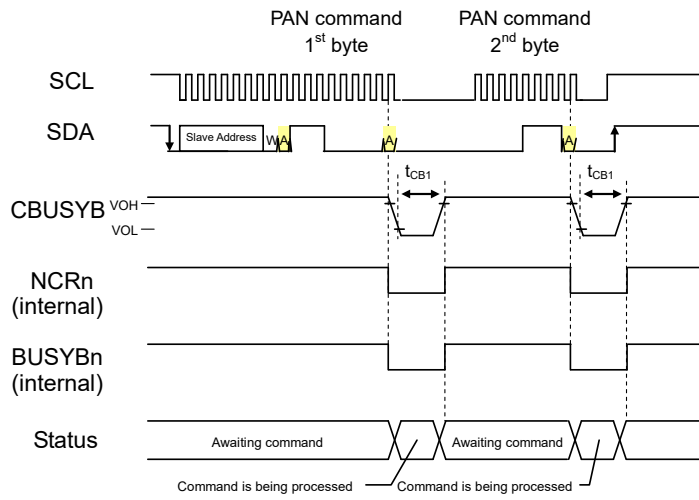

◆ SAICH command timing

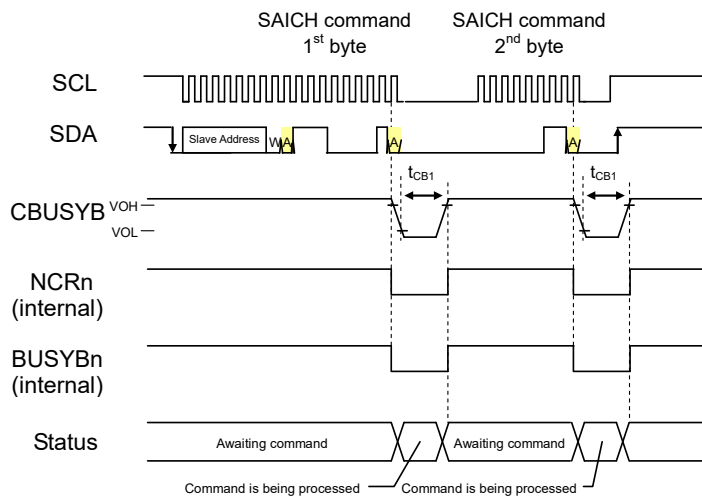

◆ SAICON command timing

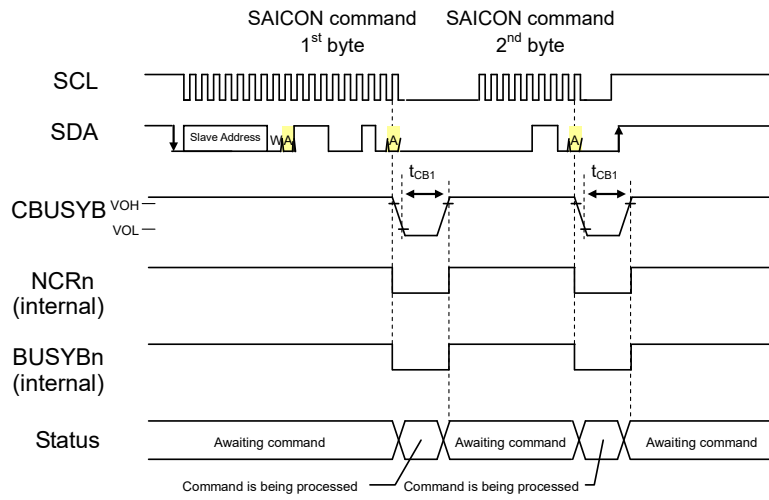

◆ SAITCON command timing

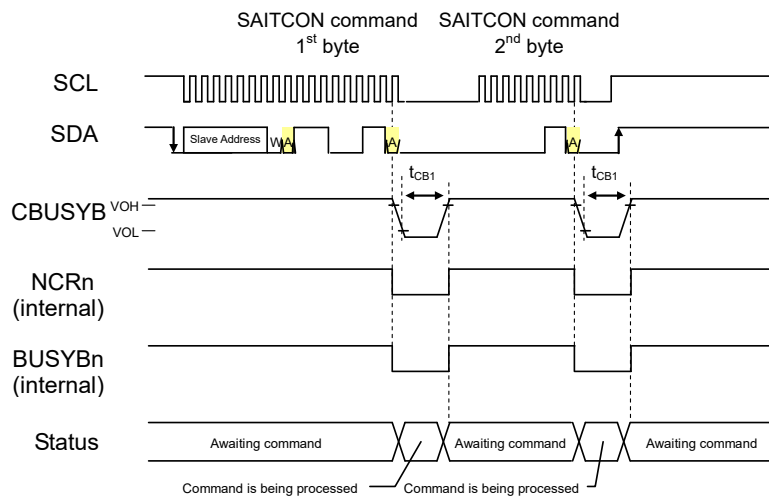

◆ SAIRCON command timing

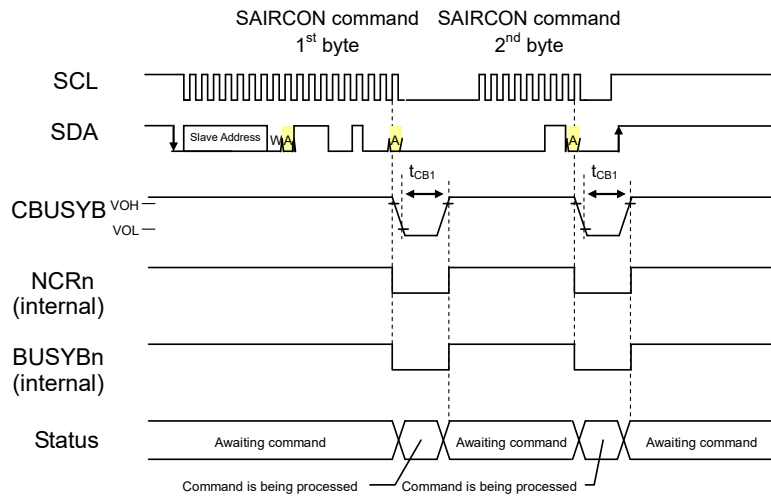

◆ SAIMOD command timing

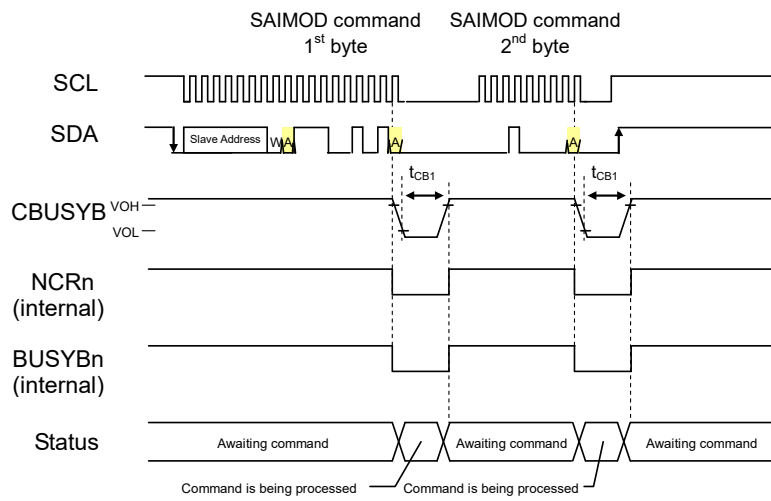

◆ Setting timing by playback sound error detection command

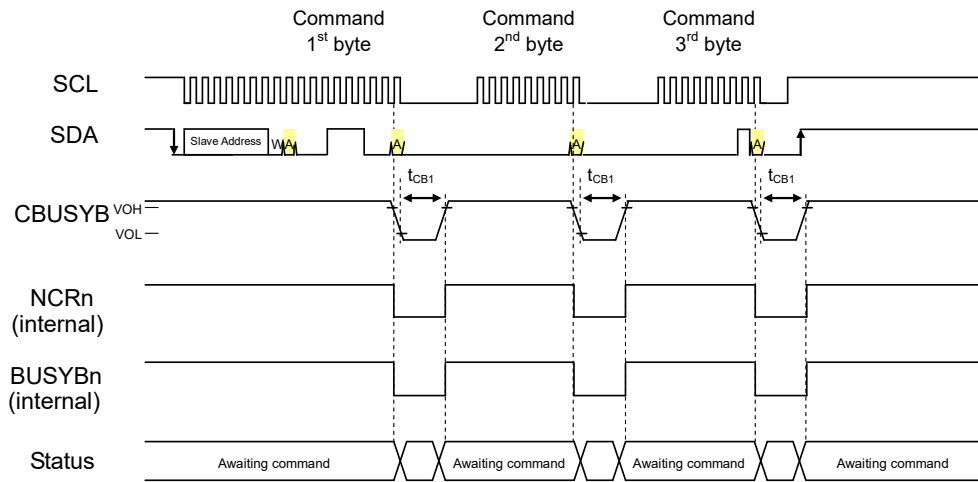

■ Command

● Command list

Each command is configured in 1-byte (8-bit) units. The PUP, WDTCL, PDWN, START, STOP, SLOOP, CLOOP and ERRCL commands are configured by one byte, the FADR2 and PLAY2 command and playback sound error detection command group are configured by three bytes, and the other commands are configured by two bytes.

Do not enter command that is not described in this manual. Enter the command with the CBUSYB "H".

Command name	D7	D6	D5	D4	D3	D2	D1	D0
PUP	0	0	0	0	0	0	0	WCM
AMODE	0	0	0	0	0	1	DAMP	HPF
	FAD	DAG1	DAG0	AIG1	AIG0	AEN1	AEN0	POP
AVOL	0	0	0	0	1	0	0	0
	0	0	AV5	AV4	AV3	AV2	0	0
FADE	0	0	0	0	1	1	0	0
	0	0	0	0	FCON2	FCON1	FCON0	FADE
FDIRECT	0	0	0	1	0	0	0	0
	PRT7	PRT6	PRT5	PRT4	PRT3	PRT2	PRT1	PRT0
WDTCL	0	0	0	1	0	1	0	0
PDWN	0	0	1	0	0	0	0	0
FADR	0	0	1	1	F9	F8	C1	C0
	F7	F6	F5	F4	F3	F2	F1	F0
PLAY	0	1	0	0	F9	F8	C1	C0
	F7	F6	F5	F4	F3	F2	F1	F0
START	0	1	0	1	CH3	CH2	CH1	CH0
STOP	0	1	1	0	CH3	CH2	CH1	CH0
MUON	0	1	1	1	CH3	CH2	CH1	CH0
	M7	M6	M5	M4	M3	M2	M1	M0
SLOOP	1	0	0	0	CH3	CH2	CH1	CH0
CLOOP	1	0	0	1	CH3	CH2	CH1	CH0
CVOL	1	0	1	0	CH3	CH2	CH1	CH0
	0	CV1	CV0	CV6	CV5	CV4	CV3	CV2
RDSTAT	1	0	1	1	0	0	0	0
	BUSYB3	BUSYB2	BUSYB1	BUSYB0	NCR3	NCR2	NCR1	NCR0
RDVER	1	0	1	1	0	1	0	0
	VER7	VER6	VER5	VER4	VER3	VER2	VER1	VER0
RDERR	1	0	1	1	1	0	0	ERSEL
	OSCERR/ MIXERR	RSTERR/ SAINERR	WDTERR/ LRCKERR	ROMERR/ BCKERR	SPDERR/	TSDERR/	DCDERR/ /	WCMER R/
OUTSTAT	1	1	0	0	0	0	0	0
	0	PORT	STA1	STA0	CH3	CH2	CH1	CH0
FADR2	1	1	0	0	0	1	0	0
	0	0	C1	C0	F11	F10	F9	F8
	F7	F6	F5	F4	F3	F2	F1	F0
PLAY2	1	1	0	0	1	0	0	0
	0	0	C1	C0	F11	F10	F9	F8
	F7	F6	F5	F4	F3	F2	F1	F0
SAFE	1	1	0	1	0	0	0	ERSEL
	OSCEN/ MIXEN	RSTEN/ SAINEN	WDTEN/ LRCKEN	ROMEN/ BCKEN	SPDEN/	TSDEN/	DCDEN/	WCMEN/ WVDIFEN
ERRCL	1	1	1	1	1	1	1	1

Command name	D7	D6	D5	D4	D3	D2	D1	D0
PAN	1	1	1	1	0	0	C1	C0
	R3	R2	R1	R0	L3	L2	L1	L0
SAICH	1	1	1	0	0	0	0	1
	0	LC1	LC0	LEN	0	RC1	RC0	REN
SAICON	1	1	1	0	0	0	1	0
	FS3	FS2	FS1	FS0	0	1	INEN	OUTEN
SAITCON	1	1	1	0	0	0	1	1
	BWO	0	0	MSBO	ISSCKO	0	DLYO	WSLO
SAIRCON	1	1	1	0	0	1	0	0
	BWI	0	0	MSBI	ISSCKI	AFOI	DLYI	WSLI
SAIMOD	1	1	1	0	0	1	0	1
	0	0	0	BSWP	0	0	0	0

The playback sound error detection command group is a single command in three bytes, and can be read by setting the RW bit in the first byte to 0, and can be written by setting the RW bit to 1.

For details on the playback sound error detection command, refer to How to use the playback sound error detection function.

The following is the playback sound error detection command group.

Command name	D7	D6	D5	D4	D3	D2	D1	D0
SCMODE	0	0	0	1	1	RW	0	0
	0	0	0	0	0	0	0	0
	1	0	0	0	0	0	AINDET	FBPATH
WVDIFTH	0	0	0	1	1	RW	0	0
	0	0	0	1	1	1	1	0
	WVDIFS TH3	WVDIFS TH2	WVDIFS TH1	WVDIFS TH0	WVDIFD TH3	WVDIFD TH2	WVDIFD TH1	WVDIFD TH0
WVDIFEDA TH	0	0	0	1	1	RW	0	0
	0	0	1	0	0	0	1	1
	0	0	DIFE DAT13	DIFE DAT12	DIFE DAT11	DIFE DAT10	DIFE DAT09	DIFE DAT08
WVDIFEDA TL	0	0	0	1	1	RW	0	0
	0	0	1	0	0	1	0	0
	DIFE DAT07	DIFE DAT06	DIFE DAT05	DIFE DAT04	DIFE DAT03	DIFE DAT02	DIFE DAT01	DIFE DAT00

● Description of Command Functions

◆ PUP command

- Command

0	0	0	0	0	0	0	WCM
---	---	---	---	---	---	---	-----

The PUP command shifts from the power-down state to the command standby state.

Since only the PUP command is accepted when the LSI is in the power-down state, the command is ignored if another command is input.

To return to the power-down mode, enter the PDWN command.

The WCM bit is used to set the mode for inputting command and data two-times. When this bit is set to "1", the subsequent command and data inputs are set to the two-times input mode, and the command is accepted only when they match.

If they do not match, the accepted command is discarded. Refer to the "RDSTAT command", "OUTSTAT command", and "SAFE command" for handling when a mismatch occurs.

Even if two-times input modes are used for the I²C interface, one-time input is used for the slave address input. If the slave address matches, ACK is returned. If the slave address does not match, NACK is returned. The command is input two-times.

WCM	Description
0	Do not use input mode two-times. (Initial value)
1	Use the two-times input mode

For the power-up timing by the PUP command, refer to the "Power-up timing" in the timing chart.

◆ AMODE command

• Command	0	0	0	0	0	1	DAMP	HPF	1st byte
	FAD	DAG1	DAG0	AIG1	AIG0	AEN1	AEN0	POP	2nd byte

The AMODE command sets the analog part.

The AMODE command is ignored during power-down, power-up transition, power-down transition and playback sound.

When the PDWN command is input while powering up the analog parts, the LSI power downs without pop noise suppression.

When power down with POP noise suppression, to set the PDWN command after powering down with AMODE command.

To perform power-down under a setting condition that differs from the power-up condition of the analog unit, set the AMODE command to set the power-down condition again.

To power up the analog part, set the CVOL command to 00h (initial value) and then enter the AMODE command.

The settings are initialized when the reset is released or when the PDWN command is inputted.

Each setting is as follows.

DAMP	Description
0	Use Class AB amplifier for speaker amplifier output.
1	Use Class D amplifier for speaker amplifier output.

When using line amplifier and using analog mixing from the AIN pin, set DAMP = "0" (Class AB amplifier is used). In this LSI, select DAMP = "0" (Class AB amplifier is used).

HPF	Description
0	No high-pass filter is used.
1	Use a high-pass filter with a cut-off frequency of 200Hz

FAD	Description
0	Fade-out is not processed when inputting STOP command.
1	Fade out when inputting STOP command

The fade-out processing BUSYB signal becomes "L" and becomes "H" after processing is completed.

DAG1	DAG0	Description
0	0	Internal DAC signal input OFF
0	1	Internal DAC signal input ON (-6 dB)
1	0	Internal DAC signal input ON (0dB)
1	1	Internal DAC signal input ON (0dB) (setting prohibited)

The setting is enabled in the speaker amplifier output mode when using Class AB amplifier. Refer to the "Volume Settings" in the "Function description".

AIG1	AIG0	Description
0	0	Analog input from the AIN pin OFF
0	1	Analog input from AIN pin ON (-6 dB)
1	0	Analog input from AIN pin ON (0dB)
1	1	Analog input from AIN pin ON (0dB) (setting prohibited)

Input the sound signals to the AIN pin after CBUSYB pin becomes "H" by the AMODE command.

The setting is enabled in the speaker amplifier output mode only when using Class AB amplifier.

Refer to the "Volume Settings" in the "Function description".

POP	Description
0	Without pop noise suppression
1	With pop noise suppression

This bit is valid when line amplifier output is selected.

When power up with pop noise suppression, the line amplifier output rises from the DGND level to the SG level at the specified time (tPUPA2). When power down with pop noise suppression, the line amplifier output falls from the SG level to the DGND level at the specified time (tPDA2).

When power up without pop noise suppression, the line amplifier output rises from the DGND level to the SG level at the specified time (tPUPA3). When power down without pop noise suppression, the line amplifier output falls from the SG level to the DGND level at the specified time (tPDA3).

The settings of the AEN1/AEN0/POP bits for power-down and power-up of the analog section when the speaker amplifier output and line amplifier output are as follows.

Mode	AEN1	AEN0	POP	Description
Speaker amplifier output (Class AB amplifier)	0	0	*1	In the power-down state or changeover to the power-down state.
	0	1	*1	In the power-up state or changeover to the power-up state
Line amplifier output (When using SPP pin)	0	0	0	In the power-down state or changeover to the power-down state without Pop Noise Suppression
	1	0	0	In the power-up state or changeover to the power-up state without Pop Noise Suppression
	0	0	1	In the power-down state or changeover to the power-down state with pop noise suppression
	1	0	1	In the power-up state or changeover to the power-up state with pop noise suppression
Line amplifier output (When using LOUT pin)	0	0	0	In the power-down state or changeover to the power-down state without Pop Noise Suppression
	1	1	0	In the power-up state or changeover to the power-up state without Pop Noise Suppression
	0	0	1	In the power-down state or changeover to the power-down state with pop noise suppression
	1	1	1	In the power-up state or changeover to the power-up state with pop noise suppression

*1 Settings can be enabled for both 0 and 1.

Pin states at AMODE power-down are as follows.

Analog output pin	Condition
V _{DDL}	2.5V(typ)
SG	DGND
SPM	HiZ
SPP	SPGND
LOUT	DGND

The timing of AMODE command is shown in the timing chart.

"Speaker amplifier power-up timing (DAMP bit "0", AEN1 bit "0", AEN0 bit "0"→"1")"

"Line amplifier power-up timing (DAMP bit = "0", POP bit = "1", AEN1 bit = "0" → "1", AEN0 bit = "0")"

"Line amplifier power-up timing (DAMP bit = "0", POP bit = "0", AEN1 bit = "0" → "1", AEN0 bit = "0")"

"Line amplifier power-up timing (DAMP bit "0", POP bit "1", AEN1 bit "0" → "1", AEN0 bit = "0" → "1")"

"Line amplifier power-up timing (DAMP bit "0", POP bit "0", AEN1 bit "0" → "1", AEN0 bit = "0" → "1")"

"Speaker amplifier power-down timing (DAMP bit "0", AEN1 bit "0", AEN0 bit "1"→"0")"

"Line amplifier power-down timing (DAMP bit = "0", POP bit = "1", AEN1 bit = "1" → "0", AEN0 bit = "0")"

"Line amplifier power-down timing (DAMP bit = "0", POP bit = "0", AEN1 bit = "1" → "0", AEN0 bit = "0")"

"Line amplifier power-down timing (DAMP bit = "0", POP bit = "1", AEN1 bit = "1" → "0", AEN0 bit = "1" → "0")"

"Line amplifier power-down timing (DAMP bit = "0", POP bit = "0", AEN1 bit = "1" → "0, AEN0 bit = "1" → "0")"

◆ AVOL command

• Command	0	0	0	0	1	0	0	0	1st byte
	0	0	AV5	AV4	AV3	AV2	0	0	2nd byte

The AVOL command sets the volume of the speaker amplifier. This command can be input regardless of the NCR signal status.

The initial value after reset release is set to -4.0dB. Also, the setting values of the AVOL command are retained when the STOP command is inputted, but they are initialized when the power is down.

AV5-AV2	Description	AV5-AV2	Description
F	+12.0dB	7	-8.0dB
E	+10.0dB	6	-12.0dB
D	+8.0dB	5	-18.0dB
C	+6.0dB	4	-26.0dB
B	+4.0dB	3	-34.0dB
A	+2.0dB	2	Prohibited
9	+0.0dB	1	Prohibited
8	-4.0dB (initial value)	0	OFF

For timing of the AVOL command, refer to the "Change volume timing by AVOL command" in the timing chart.

◆ FADE command

Command	0	0	0	0	1	1	0	0	1st byte
	0	0	0	0	FCON2	FCON1	FCON0	FADE	2nd byte

The FADE command sets the Fade function. This command can be input regardless of the NCR signal status. By using the fade function, the volume changes stepwise when the volume is changed by the CVOL command or the PAN command.

FADE	Description
0	Fade function disabled (initial value)
1	Fade function enabled

FCON2 to FCON0 set the volume that changes at every unit-time (sampling group period ^{*1}) when the volume is changed to the volume set by the CVOL command or the PAN command.

FCON2	FCON1	FCON0	Description
0	0	0	Volume change in 0 dB × 128/32768 steps
0	0	1	Volume change in 0 dB × 64/32768 steps
0	1	0	Volume change in 0 dB × 32/32768 steps
0	1	1	Volume change in 0 dB × 16/32768 steps
1	0	0	Volume change in 0 dB × 8/32768 steps
1	0	1	Volume change in 0 dB × 4/32768 steps
1	1	0	Volume change in 0 dB × 2/32768 steps
1	1	1	Volume change in 0 dB × 1/32768 steps

The smaller the voltage step that changes for each sampling frequency group, the less the pop noise, but the longer the transition time until the set volume is reached. The transition time is expressed by the following equation.

Volume-transition time for CVOL command

$$= [\text{Current CVOL setting}] - [\text{New CVOL setting}] \\ \times [\text{Sampling-frequency group}^{*1}] \\ \times \{ 264 \div (256 \div 2^{[\text{FCON2-FCON0 setting}]}) \}^{*2}$$

*1 Sampling frequency group

At 10.7/21.3kHz:	23.44μs
At 6.4/12.8/25.6kHz:	39.06μs
At 8.0/16.0/32.0kHz:	31.25μs
At 11.025/22.05/44.1kHz:	22.68μs
At 12.0/24.0/48.0kHz:	20.83μs

*2 Rounding up after the decimal point

For the timing of the FADE command, refer to the "FADE command timing" in the timing chart.

◆ FDIRECT command

· Command	0	0	0	1	0	0	0	0	1st byte
	PRT7	PRT6	PRT5	PRT4	PRT3	PRT2	PRT1	PRT0	2nd byte

The FDIRECT command controls accesses to the serial flash memory using the clock-synchronous serial interface. Input the command after inputting the PUP command.

Do not enter this command because this command is ignored when this command is entered from the I²C interface.

If the protection code of the flash memory area is not 0x69 and the protection codes (PRT7 to PRT0) entered in the second byte match the protection code set when creating sound data, the serial flash memory access mode is entered. After that, the flash memory can be accessed using the clock synchronous serial interface.

If the protection code set when creating sound data is 0x69, the flash memory does not change to serial flash memory access mode even if the code matches.

To cancel the serial flash memory access mode, insert a reset (RESETB = "L") and conduct initialization or turn off the power supply.

For the protection codes of the flash memory area, refer to the "Speech LSI Utility Setting Items".

For the timing of the FDIRECT command, refer to the "FDIRECT command timing" in the timing chart.

◆ WDTCL command

- Command

0	0	0	1	0	1	0	0
---	---	---	---	---	---	---	---

The WDTCL command clears the watchdog timer counter (WDT counter). This command can be input regardless of the NCR signal status.

For information about the operation of the watchdog timer, refer to the "Misoperation detection and failure detection functions (Watchdog timer overflow detection)" in the "Function description".

For the timing of WDTCL command, refer to the "WDTCL command timing" in the timing chart.

◆ PDWN command

- Command

0	0	1	0	0	0	0	0
---	---	---	---	---	---	---	---

The PDWN command is used to shift from the command standby state to the power-down state. The various settings are initialized, so the initial settings are required after power-up. It is invalid when the BUSYB signals of any channels are "L".

After inputting the PDWN command, oscillation stops following the elapse of the command processing time (t_{PD}).

The states of the analog output pins during power-down are shown below.

Analog output pin	Condition
V _{DDL}	DGND
SG	DGND
SPM	HiZ
SPP	SPGND
LOUT	DGND

For the power-down timing by PDWN command, refer to the "Power-Down timing" in the timing chart.

◆ FADR command

• Command	0	0	1	1	F9	F8	C1	C0	1st byte
	F7	F6	F5	F4	F3	F2	F1	F0	2nd byte

The FADR command sets the channels and phrases to be played. This command can be input when the NCR signal of the corresponding channel is "H" level.

Playback is started by the START command after the playback phrases of each channel are specified.

The phrases (F9-F0) to be played back are specified when creating sound data. Set the phrase specified when creating.

This command can only set up to 0 to 1023 phrases. To specify 1024 phrases or more, use FADR2 command.

The channel settings are as follows:

C1	C0	Description
0	0	Channel 0
0	1	Channel 1
1	0	Channel 2
1	1	Channel 3

For the timing of the FADR command, refer to the "Setting playback phrases using FADR command" in the timing chart.

◆ PLAY command

· Command	0	1	0	0	F9	F8	C1	C0	1st byte
	F7	F6	F5	F4	F3	F2	F1	F0	2nd byte

The PLAY command is played by specifying channels and phrases. This command can be input when the NCR signal of the corresponding channel is "H" level.

The phrases (F9-F0) to be played back are specified when creating sound data. Set the phrase specified when creating. This command can only set up to 0 to 1023 phrases. To specify 1024 phrases or more, use PLAY2 command.

The channel settings are as follows:

C1	C0	Description
0	0	Channel 0
0	1	Channel 1
1	0	Channel 2
1	1	Channel 3

For the playback start timing by the PLAY command, refer to the "Playback start timing by PLAY command" in the timing chart.

For the timing of continuous playback, refer to the "Continuous playback timing by PLAY command" in the timing chart.

◆ START command

• Command

0	1	0	1	CH3	CH2	CH1	CH0
---	---	---	---	-----	-----	-----	-----

 1st byte

The START command starts playing back the specified channels. Specify the phrase to be played by the FADR command prior to entering the START command. Setting the CH0 to CH3 bit to 1 plays back the corresponding channel. This command can be input when the NCR signal of the corresponding channel is "H" level.

The channel settings are as follows:

Channeled	Description
CH0	When this bit is set to 1, channel 0 is played back.
CH1	When this bit is set to 1, channel 1 is played back.
CH2	When this bit is set to 1, channel 2 is played back.
CH3	When this bit is set to 1, channel 3 is played back.

Be sure to specify one of the channels for the channel setting (CH0-CH3).

Do not input it to "0" (all "0") with specifying nothing. If it is input with specifying nothing (all "0"), the command is ignored.

For the playback start timing by the START command, refer to the "Playback start timing by START command" in the timing chart.

For the timing of continuous playback, refer to the "Continuous playback timing by START command" in the timing chart.

◆ STOP command

• Command

0	1	1	0	CH3	CH2	CH1	CH0
---	---	---	---	-----	-----	-----	-----

 1st byte

The STOP command stops playing back the specified channel. Setting the CH0 to CH3 bit to "1" stops playback of the corresponding channel. When the corresponding channel stops playing back, the NCR and BUSYB signals become "H".

The STOP command can be input regardless of the status of the NCR during playback operation. However, following the elapse of CBUSYB "L" level output time 3 (tCB3), input the next command after confirming that the BUSYB signal becomes "H".

If the BUSYB signal does not become "H", enter the STOP command again.

Refer to the "Playback stop flow" in the command flowchart for more information.

The channel settings are as follows:

Channeled	Description
CH0	Setting this bit to 1 stops channel 0.
CH1	Setting this bit to 1 stops channel 1.
CH2	Setting this bit to 1 stops channel 2.
CH3	Setting this bit to 1 stops channel 3.

Be sure to specify one of the channels for the channel setting (CH0-CH3).

Do not input it to "0" (all "0") with specifying nothing. If it is input with specifying nothing (all "0"), the command is ignored.

For the timing of the STOP command, refer to the "STOP command (when the FAD bit is "L")" and "STOP command (when the FAD bit is "H")" in the timing chart.

◆ MUON command

• Command	0	1	1	1	CH3	CH2	CH1	CH0	1st byte
	M7	M6	M5	M4	M3	M2	M1	M0	2nd byte

The MUON command inserts silence between two phrases to be played. This command can be inputted when the NCR signal of the corresponding channel is "H" level.

Repeated playing back (the SLOOP command) of the MUON command is not possible.

The silence duration (t_{mu}) is specified by the M7-M0 bits and can be set from 20ms to 1,024ms in 252 steps at 4ms intervals. The equation for setting the silence duration (t_{mu}) is as follows.

However, set the silence setting (M7-M0) to 04h or more ($t_{\text{mu}} \geq 20\text{ms}$).

$$t_{\text{mu}} = (2^7 \times (M7) + 2^6 \times (M6) + 2^5 \times (M5) + 2^4 \times (M4) + 2^3 \times (M3) + 2^2 \times (M2) + 2^1 \times (M1) + 2^0 \times (M0) + 1) \times 4\text{ms}$$

The channel settings are as follows:

Channeled	Description
CH0	Setting this bit to 1 inserts silence into channel 0.
CH1	Setting this bit to 1 inserts silence into channel 1.
CH2	Setting this bit to 1 inserts silence into channel 2.
CH3	Setting this bit to 1 inserts silence into channel 3.

Be sure to specify one of the channels for the channel setting (CH0-CH3).

Do not input it to "0" (all "0") with specifying nothing. If it is input with specifying nothing (all "0"), the command is ignored.

For the timing of the MUON command, refer to the "Playback start timing by MUON command" in the timing chart.

For the timing of continuous playback, refer to the "Continuous playback timing by MUON command" in the timing chart.

◆ SLOOP command

• Command

1	0	0	0	CH3	CH2	CH1	CH0
---	---	---	---	-----	-----	-----	-----

 1st byte

The SLOOP command sets the repeat playback of the specified channel. Setting the CH0 to CH3 bit to 1 repeatedly plays back the corresponding channel. This command can be input when the NCR signal of the corresponding channel is "H" level.

When repeat playback is set, playback is repeatedly performed until the repeat playback setting is canceled by the CLOOP command or playback is stopped by the STOP command. Also, if the phrase has been edited, the edited phrase is played repeatedly.

The channel settings are as follows:

Channeled	Description
CH0	Setting this bit to 1 repeats playback on channel 0.
CH1	Setting this bit to 1 repeats playback on channel 1.
CH2	Setting this bit to 1 repeats playback on channel 2.
CH3	Setting this bit to 1 repeats playback on channel 3.

Be sure to specify one of the channels for the channel setting (CH0-CH3).

Do not input it to "0" (all "0") with specifying nothing. If it is input with specifying nothing (all "0"), the command is ignored.

For the timing of the SLOOP command, refer to the "Repeat playback setting/release timing by SLOOP/CLOOP command" in the timing chart.

◆ CLOOP command

• Command

1	0	0	1	CH3	CH2	CH1	CH0
---	---	---	---	-----	-----	-----	-----

 1st byte

The CLOOP command releases repeat playback of the specified channel. This command can be input regardless of the NCR signal status.

Setting the CH0 to CH3 bit to "1" cancels repeat playback of the corresponding channel. When repeat playback is released, the NCR signal becomes "H" level.

The channel settings are as follows:

Channeled	Description
CH0	Setting this bit to 1 cancels repeat playback on channel 0.
CH1	Setting this bit to 1 cancels repeat playback on channel 1.
CH2	Setting this bit to 1 cancels repeat playback on channel 2.
CH3	Setting this bit to 1 cancels repeat playback on channel 3.

Be sure to specify one of the channels for the channel setting (CH0-CH3).

Do not input it to "0" (all "0") with specifying nothing. If it is input with specifying nothing (all "0"), the command is ignored.

For the timing of the CLOOP command, refer to the "Repeat playback setting/release timing by SLOOP/CLOOP command" in the timing chart.

◆ CVOL command

• Command	1	0	1	0	CH3	CH2	CH1	CH0	1st byte
	0	CV1	CV0	CV6	CV5	CV4	CV3	CV2	2nd byte

The CVOL command sets the playback volume of the specified channel. This command can be input regardless of the NCR signal status.

Setting the CH0 to CH3 bit to 1 sets the volume of the corresponding channel.

The volume can be set at 128 levels.

The setting values are initialized when a reset is inserted (RESETB = "L") and PDWN command is input.

The CV1 and CV0 of the second bytes of the CVOL command are located at the top of the CV6 to CV2.

CV1,CV0, CV6-CV2	Description	CV1,CV0, CV6-CV2	Description	CV1,CV0, CV6-CV2	Description	CV1,CV0, CV6-CV2	Description
00	0.00dB (initial value)	08	-2.59dB	10	-6.31dB	18	-12.93dB
20	-0.07dB	28	-2.69dB	30	-6.45dB	38	-13.24dB
40	-0.14dB	48	-2.78dB	50	-6.60dB	58	-13.57dB
60	-0.21dB	68	-2.88dB	70	-6.75dB	78	-13.91dB
01	-0.28dB	09	-2.98dB	11	-6.90dB	19	-14.26dB
21	-0.36dB	29	-3.08dB	31	-7.06dB	39	-14.63dB
41	-0.43dB	49	-3.18dB	51	-7.22dB	59	-15.02dB
61	-0.50dB	69	-3.28dB	71	-7.38dB	79	-15.42dB
02	-0.58dB	0A	-3.38dB	12	-7.55dB	1A	-15.85dB
22	-0.65dB	2A	-3.49dB	32	-7.72dB	3A	-16.29dB
42	-0.73dB	4A	-3.59dB	52	-7.89dB	5A	-16.76dB
62	-0.81dB	6A	-3.70dB	72	-8.06dB	7A	-17.26dB
03	-0.88dB	0B	-3.81dB	13	-8.24dB	1B	-17.79dB
23	-0.96dB	2B	-3.92dB	33	-8.43dB	3B	-18.35dB
43	-1.04dB	4B	-4.03dB	53	-8.61dB	5B	-18.95dB
63	-1.12dB	6B	-4.14dB	73	-8.80dB	7B	-19.59dB
04	-1.20dB	0C	-4.25dB	14	-9.00dB	1C	-20.28dB
24	-1.28dB	2C	-4.37dB	34	-9.20dB	3C	-21.04dB
44	-1.36dB	4C	-4.48dB	54	-9.40dB	5C	-21.87dB
64	-1.44dB	6C	-4.60dB	74	-9.61dB	7C	-22.78dB
05	-1.53dB	0D	-4.72dB	15	-9.83dB	1D	-23.81dB
25	-1.61dB	2D	-4.84dB	35	-10.05dB	3D	-24.97dB
45	-1.70dB	4D	-4.97dB	55	-10.27dB	5D	-26.31dB
65	-1.78dB	6D	-5.09dB	75	-10.50dB	7D	-27.89dB
06	-1.87dB	0E	-5.22dB	16	-10.74dB	1E	-29.83dB
26	-1.96dB	2E	-5.35dB	36	-10.99dB	3E	-32.33dB
46	-2.04dB	4E	-5.48dB	56	-11.24dB	5E	-35.85dB
66	-2.13dB	6E	-5.61dB	76	-11.50dB	7E	-41.87dB
07	-2.22dB	0F	-5.74dB	17	-11.77dB	1F	-44.37dB
27	-2.31dB	2F	-5.88dB	37	-12.04dB	3F	-47.89dB
47	-2.41dB	4F	-6.02dB	57	-12.33dB	5F	-53.91dB
67	-2.50dB	6F	-6.16dB	77	-12.62dB	7F	OFF

The volume can also be set at 32 levels by fixing the CV1 and CV0 bits to "0".

CV6-CV2	Description	CV6-CV2	Description
00	0.00dB (initial value)	10	-6.31dB
01	-0.28dB	11	-6.90dB
02	-0.58dB	12	-7.55dB
03	-0.88dB	13	-8.24dB
04	-1.20dB	14	-9.00dB
05	-1.53dB	15	-9.83dB
06	-1.87dB	16	-10.74dB
07	-2.22dB	17	-11.77dB
08	-2.59dB	18	-12.93dB
09	-2.98dB	19	-14.26dB
0A	-3.38dB	1A	-15.85dB
0B	-3.81dB	1B	-17.79dB
0C	-4.25dB	1C	-20.28dB
0D	-4.72dB	1D	-23.81dB
0E	-5.22dB	1E	-29.83dB
0F	-5.74dB	1F	-44.37dB

The channel settings are as follows:

Channeled	Description
CH0	Setting this bit to 1 set the volume of channel 0.
CH1	Setting this bit to 1 set the volume of channel 1.
CH2	Setting this bit to 1 set the volume of channel 2.
CH3	Setting this bit to 1 set the volume of channel 3.

Be sure to specify one of the channels for the channel setting (CH0-CH3). When multiple channels are specified, the volume of the specified channels is set.

Do not input it to "0" (all "0") with specifying nothing. If it is input with specifying nothing (all "0"), the command is ignored.

For timing of the CVOL command, refer to the "Change volume timing by CVOL command" in the timing chart.

◆ RDSTAT command

• Command

1	0	1	1	0	0	0	0
---	---	---	---	---	---	---	---

 1st byte

The RDSTAT command reads the internal operating states. This command can be input regardless of the NCR signal status. When reading the status of the second byte after command input, set the SI pin to "L".

The internal operating states read in the second byte are as follows:

2nd byte	D7	D6	D5	D4	D3	D2	D1	D0
Output data	BUSYB3	BUSYB2	BUSYB1	BUSYB0	NCR3	NCR2	NCR1	NCR0

The NCR signal outputs "L" during command processing and playback standby, and outputs "H" in other states. The BUSYB signal outputs "L" during command processing and playback sound, and outputs "H" in other states.

D7 to D0	Description
BUSYB3	BUSYB outputs of channel 3
BUSYB2	BUSYB outputs of channel 2
BUSYB1	BUSYB outputs of channel 1
BUSYB0	BUSYB outputs of channel 0
NCR3	NCR output of channel 3
NCR2	NCR output of channel 2
NCR1	NCR output of channel 1
NCR0	NCR output of channel 0

For the timing of the RDSTAT command, refer to the "RDSTAT command timing" in the timing chart.

◆ RDVER command

• Command

1	0	1	1	0	1	0	0
---	---	---	---	---	---	---	---

 1st byte

The RDVER command read sound ROM information. This command can be input regardless of the NCR signal status. When reading the sound ROM information in the second byte after command input, set the SI pin to "L".

The sound ROM information read in the second byte is as follows:

2nd byte	D7	D6	D5	D4	D3	D2	D1	D0
Output data	VER7	VER6	VER5	VER4	VER3	VER2	VER1	VER0

Sound ROM information can be set by using dedicated tool (Speech LSI Utility) when creating sound data.

For the timing of the RDVER command, refer to the "RDVER command timing" in the timing chart.

◆ RDERR command

• Command

1	0	1	1	1	0	0	ERSEL
---	---	---	---	---	---	---	-------

 1st byte

The RDERR command read misoperation detection and failure detection status. This command can be input regardless of the NCR signal status. When reading error information in the second byte after command input, set the SI pin to "L".

If the outputs of misoperation detection and failure detection are selected by OUTSTAT command, and the read data is all "L" even though STATUS1 or STATUS2 pin is "H", the read data cannot be read normally. Be sure to read it again.

The data to be read differs depending on the ERSEL bit. When an error occurs, use this command to check the error information corresponding to various misoperation detection and failure detection status set by the SAFE command.

The error information read in the second byte when ERSEL = "0" is as follows.

2nd byte	D7	D6	D5	D4	D3	D2	D1	D0
Output data	OSCERR	RSTERR	WDTERR	ROMERR	SPDERR	TSDERR	DCDERR	WCMERR

The error information read in the second byte when ERSEL = "1" is as follows.

2nd byte	D7	D6	D5	D4	D3	D2	D1	D0
Output data	MIXERR	SAINERR	LRCKERR	BCKERR	0	0	0	WVDIFERR

Misoperation detection and failure detection status are as follows.

Error signal	Description
WCMERR	This bit is set to "1" when an error of the command is detected.
DCDERR	This bit is set to "1" when the disconnection of the speaker connected to the SPP and SPM pins is detected.
TSDERR	This bit is set to "1" when the LSI temperature becomes 130°C or higher.
SPDERR	This bit is set to "1" when the SPP pin and the SPM pin are short-circuited, or when the SPP pin or the SPM pin is short-circuited to GND.
ROMERR	This bit is set to 1 when an error is detected in the flash memory.
WDTERR	This bit is set to "1" when the first overflow of the watchdog timer counter occurs.
RSTERR	This bit is set to "1" when the second overflow of the watchdog timer counter occurs. Alternatively, this bit is set to "1" when the RST counter, which starts operation by any of the error detections, overflows.
OSCERR	This bit is set to "1" when the clock input from the crystal resonator or ceramic resonator is stopped.
WVDIFERR	This bit is set to "1" when an abnormality in the playback sound is detected.
BCKERR	This bit is set to "1" when the disconnection/short circuit of the BCLK is detected.
LRCKERR	This bit is set to "1" when the disconnection/short circuit of the LRCLK is detected.
SAINERR	This bit is set to "1" when the disconnection or short circuit of SAI_IN is detected.
MIXERR	This bit is set to "1" when an error in the mixing number is detected.

For details on misoperation detection and failure detection, refer to the "Misoperation detection and failure detection functions" in the "Function description".

For the timing of the RDERR command, refer to the "RDERR command timing" in the timing chart.

◆ OUTSTAT command

• Command	1	1	0	0	0	0	0	0	0	1st byte
	0	PORT	STA1	STA0	CH3	CH2	CH1	CH0		2nd byte

The OUTSTAT command selects the internal operating states output to the STATUS1 pin and STATUS2 pin. This command can be input regardless of the NCR signal status.

PORT	Description
0	STATUS1 Pin setting
1	STATUS2 Pin setting

If the STATUS2 pin is set after the STATUS1 pin is set, the STATUS1 pin setting is retained.

In the initial setting, the NCR of channel 0 is selected for the STATUS1 pin, and the BUSYB of channel 0 is selected for the STATUS2 pin.

STA1	STA0	Description
0	0	BUSYB
0	1	NCR
1	0	Misoperation detection and failure detection
1	1	

Channeled	Description
CH0	Setting this bit to 1 selects channel 0.
CH1	Setting this bit to 1 selects channel 1.
CH2	Setting this bit to 1 selects channel 2.
CH3	Setting this bit to 1 selects channel 3.

Channel settings are enabled when BUSYB or NCR is specified in the STA1/STA0. Multiple channels can also be set.

The relation between the STATUS1 pin and the STA1/STA0/CH3/CH2/CH1/CH0 are shown below.

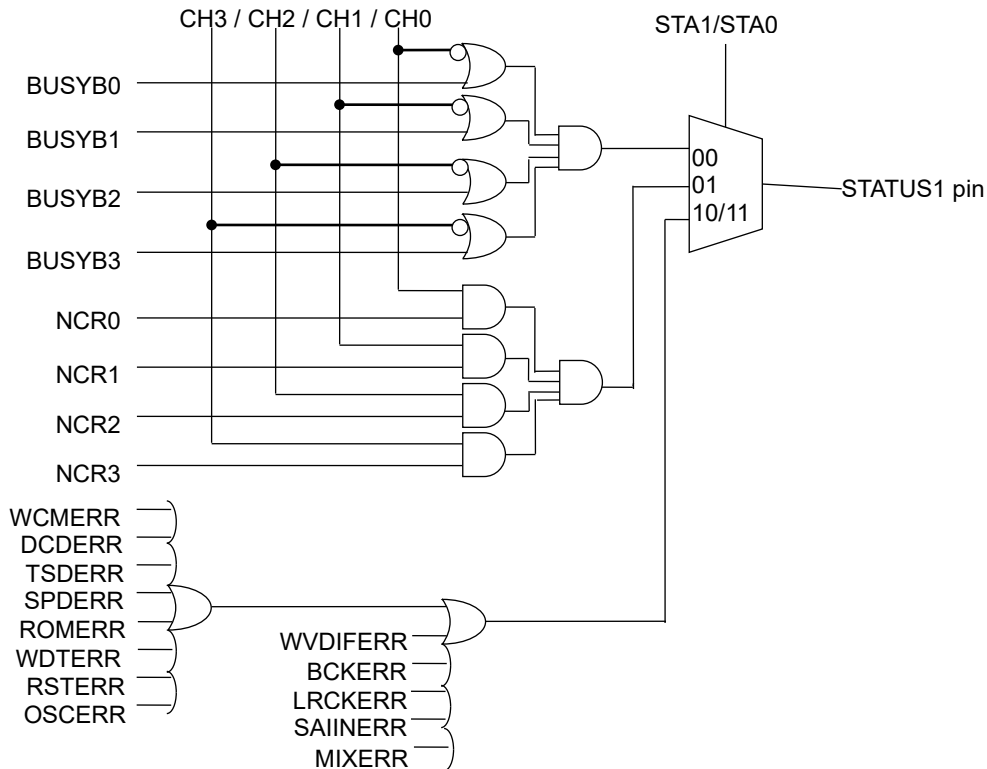

For the timing of the OUTSTAT command, refer to the "OUTSTAT command timing" in the timing chart.

◆ FADR2 command

• Command	1	1	0	0	0	1	0	0	1st byte
	0	0	C1	C0	F11	F10	F9	F8	2nd byte
	F7	F6	F5	F4	F3	F2	F1	F0	3rd byte

The FADR2 command sets the channels and phrases to be played. This command can be input when the NCR signal of the corresponding channel is "H" level.

Playback is started by the START command after the playback phrases of the channels are specified.

The phrases (F11-F0) to be played back are specified when creating sound data. Set the phrase specified when creating.

The channel settings are as follows:

C1	C0	Description
0	0	Channel 0
0	1	Channel 1
1	0	Channel 2
1	1	Channel 3

When the number of phrases to be played is 1024 or less, the channels and phrases can be specified by FADR command.

For the timing of the FADR2 command, refer to the "Setting timing of playback phrases by FADR2 command" in the timing chart.

◆ PLAY2 command

• Command	1	1	0	0	1	0	0	0	1st byte
	0	0	C1	C0	F11	F10	F9	F8	2nd byte
	F7	F6	F5	F4	F3	F2	F1	F0	3rd byte

The PLAY2 command is played by specifying channels and phrases. This command can be input when the NCR signal of the corresponding channel is "H" level.

The phrases (F11-F0) to be played back are specified when creating sound data. Set the phrase specified when creating.

The channel settings are as follows:

C1	C0	Description
0	0	Channel 0
0	1	Channel 1
1	0	Channel 2
1	1	Channel 3

When the number of phrases to be played is 1024 or less, the channels and phrases can be specified by PLAY command.

For the playback start timing by the PLAY2 command, refer to the "Playback start timing by PLAY2 command" in the timing chart.

◆ SAFE command

• Command	1	1	0	1	0	0	0	ERSEL	1st byte
When ERSEL = "0"	OSCEN	RSTEN	WDTEN	ROMEN	SPDEN	TSDEN	DCDEN	WCMEN	2nd byte
When ERSEL = "1"	MIXEN	SAIINEN	LRCKEN	BCKEN	0	0	0	WVDIFEN	2nd byte

The SAFE command is used to set the operation of the misoperation detection function and the failure detection function. The initial value is the operation stop state ("0"). When this bit is set to "1", operation starts.

Select the function to be set in the ERSEL. If ERSEL is set to "1" after setting ERSEL to "0", the function set with ERSEL = "0" is retained. The functions to be set when ERSEL = "0" are as follows.

Error setting	Description
WCMEN	Set the command error detection.
DCDEN	Set the disconnection detection of the speakers connected to the SPP and SPM pins.
TSDEN	Set the LSI temperature error detection.
SPDEN	Set the detection of short circuit between the SPP pin and the SPM pin.
ROMEN	Set error detection of flash memory.
WDTEN*1	Operate the watchdog timer and set overflow detection.
RSTEN*1	Operate the RST counter and set overflow detection, when any error is detected.
OSCEN	Enable the error output for the stop detection of clock input from a crystal resonator or ceramic resonator.

*1 Do not set WDTEN and RSTEN to "1" at the same time. If these bits are set to "1" at the same time, only the RSTEN bit is set to "1".

The functions to be set when ERSEL = "1" are as follows.

Error setting	Description
WVDIFEN	Set the playback sound error detection.
BCKEN	Set the BCLK disconnection/short detection.
LRCKEN	Set the LRCLK disconnection/short detection.
SAIINEN	Set the SAI_IN disconnection/short detection.
MIXEN	Set error detection of mixing number.

For details on misoperation detection and failure detection, refer to the "Misoperation detection and failure detection" in the function description.

For the timing of the SAFE command, refer to the "SAFE command timing" in the timing chart.

◆ ERRCL command

- Command

1	1	1	1	1	1	1	1
---	---	---	---	---	---	---	---

The ERRCL command is a command that clears error bits that can be read by the RDERR command. The ERRCL command clears all error bits irrespective of the ERSEL bit of the RDERR command. This command can be input regardless of the NCR signal status.

However, if the error continues, the error bit remains in the error status even if the ERRCL command is entered.

For the timing of the ERRCL command, refer to the "ERRCL command timing" in the timing chart.

◆ PAN command

Command	1	1	1	1	0	0	C1	C0	1st byte
	R3	R2	R1	R0	L3	L2	L1	L0	2nd byte

The PAN command sets the volume of the Lch/Rch during serial audio interface (SAI) operation. This command can be input regardless of the NCR signal status.

Set the volume during playback or before starting playback. The initial value is 0dB for both channels.

The Fade function can change the volume step by step

The channel settings are as follows:

C1	C0	Description
0	0	Channel 0
0	1	Channel 1
1	0	Channel 2
1	1	Channel 3

The volume settings are as follows:

R3/L3	R2/L2	R1/L1	R0/L0	Description
0	0	0	0	0 dB (initial value)
0	0	0	1	-0.58dB
0	0	1	0	-1.20dB
0	0	1	1	-1.87dB
0	1	0	0	-2.59dB
0	1	0	1	-3.38dB
0	1	1	0	-4.25dB
0	1	1	1	-5.22dB
1	0	0	0	-6.31dB
1	0	0	1	-7.55dB
1	0	1	0	-9.00dB
1	0	1	1	-10.74dB
1	1	0	0	-12.93dB
1	1	0	1	-15.85dB
1	1	1	0	-20.28dB
1	1	1	1	OFF

For the fade function, refer to the "FADE command".

For adjusting the Lch/Rch volume using FADE command, refer to the "Volume Settings" in the function description.

For the PAN command input timing, refer to the "Change volume timing by PAN command" in the timing chart.

◆ SAICH command

Command	1	1	1	0	0	0	0	1	1st byte
	0	LC1	LC0	LEN	0	RC1	RC0	REN	2nd byte

The SAICH command sets the operation of the serial audio interface (SAI) and the channels on the Lch and Rch sides. Set these bits when channels other than SAIs are not playing back (BUSYBn is "1").

LEN and REN set the operation of the Lch side and the Rch side.

LEN	Description
0	Stops the operation of the serial audio interface (SAI) on the Lch side (initial)
1	Starts the operation of the serial audio interface (SAI) on the Lch side.

REN	Description
0	Stops the operation of the serial audio interface (SAI) on the Rch side (initial)
1	Starts the operation of the serial audio interface (SAI) on the Rch side.

LC1 to LC0 and RC1 to RC0 specify the playback channels of the Lch and Rch sides.

RC1	RC0	Description
0	0	Specify Rch-side channel 0 (CH0).
0	1	Specify Rch-side channel 1 (CH1).
1	0	Specify Rch-side channel 2 (CH2).
1	1	Specify Rch-side channel 3 (CH3).

LC1	LC0	Description
0	0	Specify Lch-side channel 0 (CH0).
0	1	Specify Lch-side channel 1 (CH1).
1	0	Specify Lch-side channel 2 (CH2).
1	1	Specify Lch-side channel 3 (CH3).

The LEN and REN bits cannot be set to "1" when the channels specified by LC1 to LC0 and RC1 to RC0 are playing back in a mode other than SAI (BUSYBn = "L").

If you want to set LEN="0" and REN="1" with LEN="1" and REN="0", set LEN="0" and REN="1" after setting LEN=REN="0".

When LEN and REN are set to "1" with the same channel specified by LC1 to LC0 and RC1 to RC0, only the Lch operates.

Start the LRCLK/BCLK input after entering the SAICON command.

Subsequently, enter the MUON command and then the SAICH command.

After entering the MUON command, enter the SAICH command at least 10ms prior to the end of the silence period set by the MUON command.

Use a channel that is not played back by SAICH as the playback channel set by MUON commands. To mix with ROM playback, use a channel for ROM playback. When ROM playback is started within the silence time set by the MUON commands, resulting in continuous playback, ROM playback is started after the set silence time elapses.

For the timing of inputting the SAICH command, refer to the "SAICH command timing" in the timing chart.

When LRCLK is faster by 5% or more, SAICH is initialized. For LRCLK failure detection, refer to the "Function description" section.

◆ SAICON command

Command	1	1	1	0	0	0	1	0	1st byte
	FS3	FS2	FS1	FS0	0	1	INEN	OUTEN	2nd byte

The SAICON command enable/disable input/output from the serial audio interface (SAI) pins.
 Set this bit when the Lch-side serial audio interface (SAI) operation of the SAICH command is stopped (LEN="0") and the Rch-side serial audio interface (SAI) operation is stopped (REN="0"). If either LEN or REN is set to "1", the entered SAICON command is ignored.

OUTEN	Description
0	Stops SAI_OUT pin output (initial value)
1	Start SAI_OUT pin output

INEN	Description
0	Invalid SAI_IN pin input (initial value)
1	Valid SAI_IN pin input

The FS3 to FS0 selects the sampling frequency used for the serial audio interface (SAI).

FS3	FS2	FS1	FS0	Description
0	0	0	0	8 kHz (initial value)
0	0	0	1	16kHz
0	0	1	0	32kHz
0	0	1	1	Setting prohibited
0	1	0	0	11.025kHz
0	1	0	1	22.05kHz
0	1	1	0	44.1kHz
0	1	1	1	Setting prohibited
1	0	0	0	12kHz
1	0	0	1	24kHz
1	0	1	0	48kHz
1	0	1	1	Setting prohibited
1	1	0	0	Setting prohibited
1	1	0	1	Setting prohibited
1	1	1	0	Setting prohibited
1	1	1	1	Setting prohibited

The operating status for each setting of OUT_EN and IN_EN is as follows.

IN_EN	OUT_EN	Playback sound				Playback operation
		Input		Output		
		SAI_IN pin	Flash memory	SAI_OUT pin	Line amplifier or speaker amplifier	
0	0	-	✓	-	✓	Playback from flash memory to line amplifier or speaker amplifier.
0	1	-	✓	✓	-	Output from flash memory pin to SAI_OUT pin.*1
					✓	Playback from flash memory to line amplifier or speaker amplifier and SAI_OUT pin.
1	0	✓	-	-	✓	Playback from SAI_IN pin to line amplifier or speaker amplifier.
			✓			Playback the mixing of SAI_IN pin and flash memory to line amplifier or speaker amplifier.
1	1	✓	-	✓	-	Output from SAI_IN pin to SAI_OUT pin.*1
			✓			Output the mixing of SAI_IN pin and flash memory to SAI_OUT pin.*1
			-		✓	Playback from SAI_IN pin to line amplifier or speaker amplifier and SAI_OUT pin.
			✓			Playback the mixing of SAI_IN pin and flash memory to line amplifier or speaker amplifier and SAI_OUT pin.

*1: To output only to the SAI_OUT pin, set DAG1,DAG0 bit of AMODE command to 0 (internal DAC signal input OFF).

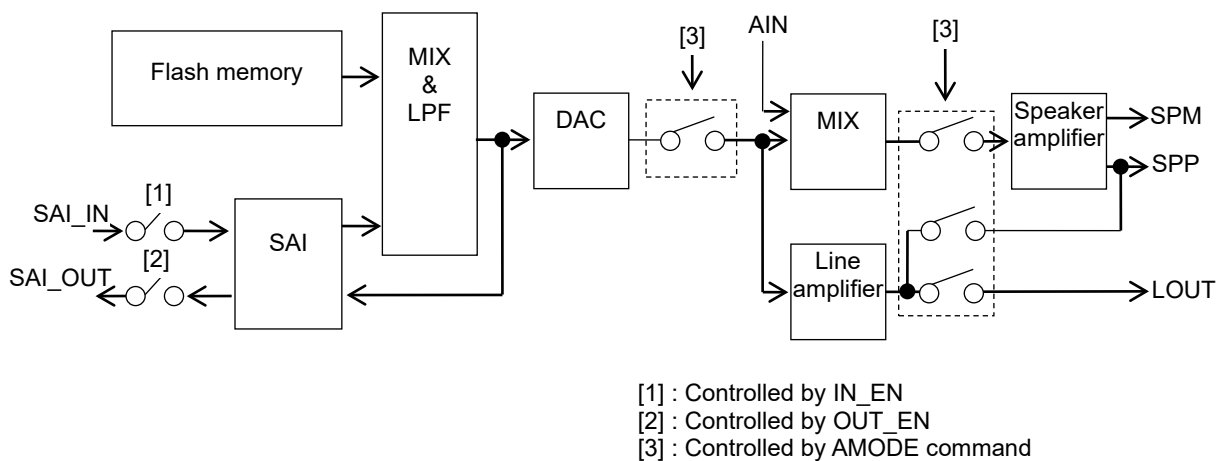

For the timing of inputting the SAICON command, refer to the "SAICON command timing" in the timing chart.

◆ SAITCON command

Command	1	1	1	0	0	0	1	1	1st byte
	BWO	0	0	MSBO	ISSCKO	0	DLYO	WSLO	2nd byte

The SAITCON command sets the serial audio interface (SAI) transmission format.

Use the same format as that of SAIRCON command.

Set this bit when the Lch-side serial audio interface (SAI) operation of the SAICH command is stopped (LEN="0") and the Rch-side serial audio interface (SAI) operation is stopped (REN="0"). If either LEN or REN is set to "1", the entered SAITCON command is ignored.

WSLO specifies the LRCLK polarities when transmitting.

WSLO	Description
0	L channel is transmitted when LRCLK is "L" level, R channel is transmitted when LRCLK is "H" level (initial value)
1	L channel is transmitted when LRCLK is "H" level, R channel is transmitted when LRCLK is "L" level

DLYO specifies whether transmit data has a 1-clock delay or not.

DLYO	Description
0	Serial data delay (initial value)
1	No serial data delay

ISSCKO specifies the BCLK pin as 32fs or 64fs.

ISSCKO	Description
0	32 fs (initial value)
1	64 fs

MSBO specifies MSB first or LSB first in the transmit data.

MSBO	Description
0	MSB first (initial value)
1	LSB first

BWO specifies the bit width for transmission.

BWO	Description
0	16-bit straight PCM (initial value)
1	8-bit straight PCMs

For the transmission format, refer to the "SAI (Serial Audio Interface)" in the function description.

For the timing of inputting the SAITCON command, refer to "SAITCON command timing" in the timing chart.

◆ SAIRCON command

Command	1	1	1	0	0	1	0	0	1st byte
	BWI	0	0	MSBI	ISSCKI	AFOI	DLYI	WSLI	2nd byte

The SAIRCON command sets the serial audio interface (SAI) reception format.

Use the same format as that of SAITCON command.

Set this bit when the Lch-side serial audio interface (SAI) operation of the SAICH command is stopped (LEN="0") and the Rch-side serial audio interface (SAI) operation is stopped (REN="0"). If either LEN or REN is set to "1", the entered SAIRCON command is ignored.

WSLI specifies the LRCLK polarities for reception.

WSLI	Description
0	L channel is received when LRCLK is "L" level, R channel is received when LRCLK is "H" level (initial value)
1	L channel is received when LRCLK is "H" level, R channel is received when LRCLK is "L" level

DLYI specifies whether the received data has a 1-clock delay or not.

DLYI	Description
0	Serial data delay (initial value)
1	No serial data delay

AFOI specifies whether the received data is left-aligned or right-aligned.

AFOI	Description
0	Left-justify (initial value)
1	Right-justify

ISSCKI specifies the BCLK pin connector as 32fs or 64fs.

ISSCKI	Description
0	32 fs (initial value)
1	64 fs

MSBI specifies MSB first or LSB first in the received data.

MSBI	Description
0	MSB first (initial value)
1	LSB first

BWI specifies the bit width for reception.

BWI	Description
0	16-bit straight PCM (initial value)
1	8-bit straight PCM

For the reception format, refer to the "SAI (Serial Audio Interface)" in the "Function description".

For the timing of inputting the SAIRCON command, refer to the "SAIRCON command timing" in the timing chart.

◆ SAIMOD command

Command	1	1	1	0	0	1	0	1	1st byte
	0	0	0	BSWP	0	0	0	0	2nd byte

The SAIMOD command sets the mode of the serial audio interface (SAI).

Set this bit when the Lch-side serial audio interface (SAI) operation of the SAICH command is stopped (LEN="0") and the Rch-side serial audio interface (SAI) operation is stopped (REN="0"). If either LEN or REN is set to "1", the entered SAIMOD command is ignored.

BSWP sets byte-swapping of the order of the the data to be transmitted and the data to be received.

BSWP	Description
0	No byte-swap (16-bit data order: 0bit-7 bit, 8bit-15 bit) (initial value)
1	With byte swap (16-bit data order: 8bit-15 bit, 0bit-7 bit)

For the timing of inputting the SAIMOD command, refer to the "SAIMOD command timing" in the timing chart.

■ Command flowchart

- 1-byte command input flow(Applies to PUP, WDTCL, PDWN, START, STOP, SLOOP, CLOOP, and ERRCL commands.)

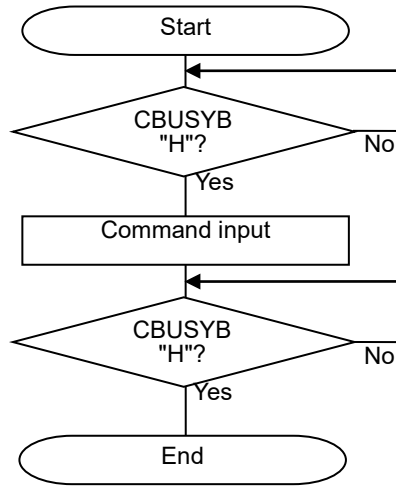

- 2-byte command input flow(Applies to AMODE, AVOL, FADE, FDIRECT, FADR, PLAY, MUON, CVOL, OUTSTAT, SAFE, PAN, and SAICH, SAICON, SAITCON, SAIRCON, SAIMOD commands.)

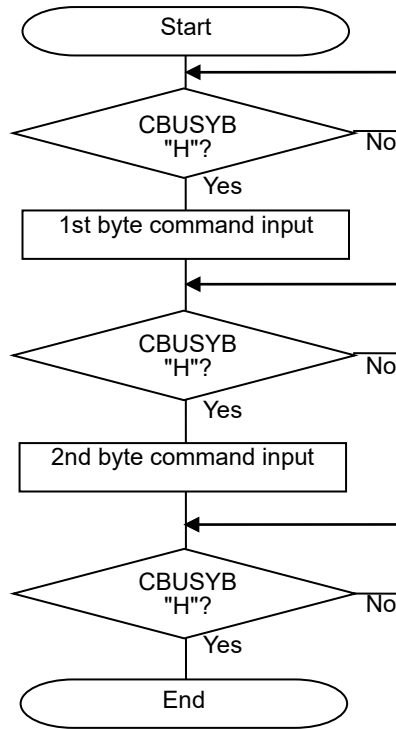

- 3-byte command input flow(Applies to FADR2, PLAY2 and playback sound error detection command group)

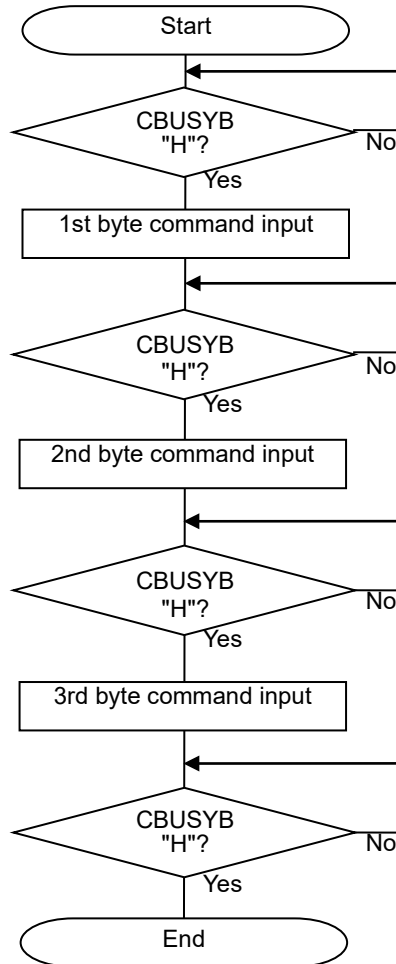

- Read flow (Applies to RDSTAT, RDVER, RDERR commands)

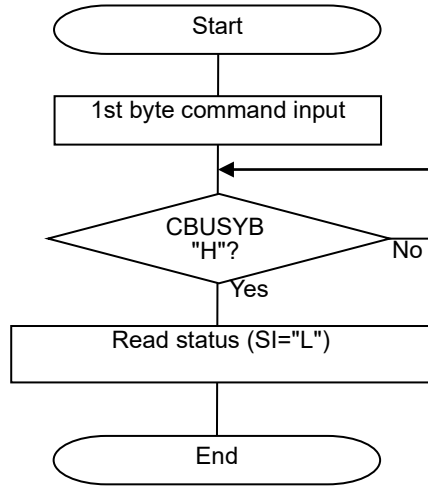

- Read flow (Applies to playback sound error detection command group)

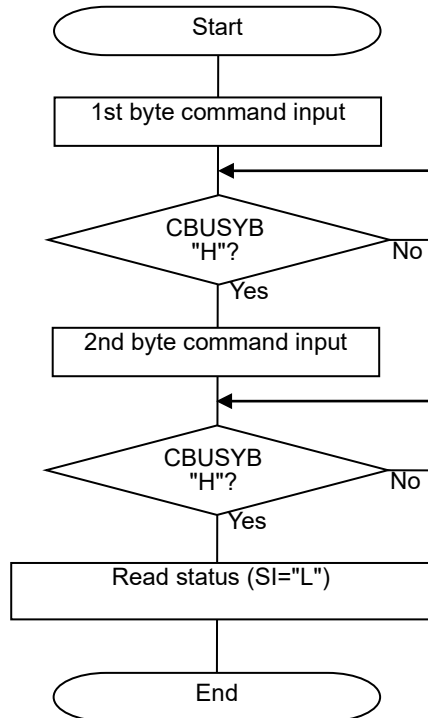

● Power-on flow

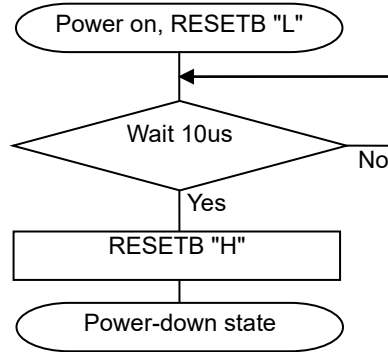

● MCU command interface serial flash memory access migration

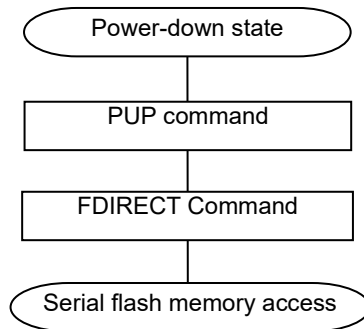

● MCU command interface serial flash memory access cancel

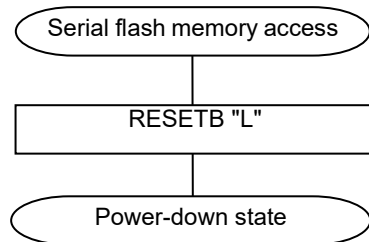

● Analog power-up flow

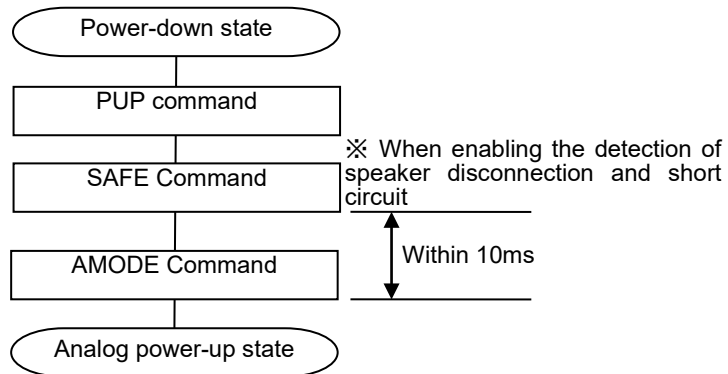

● Playback start flow

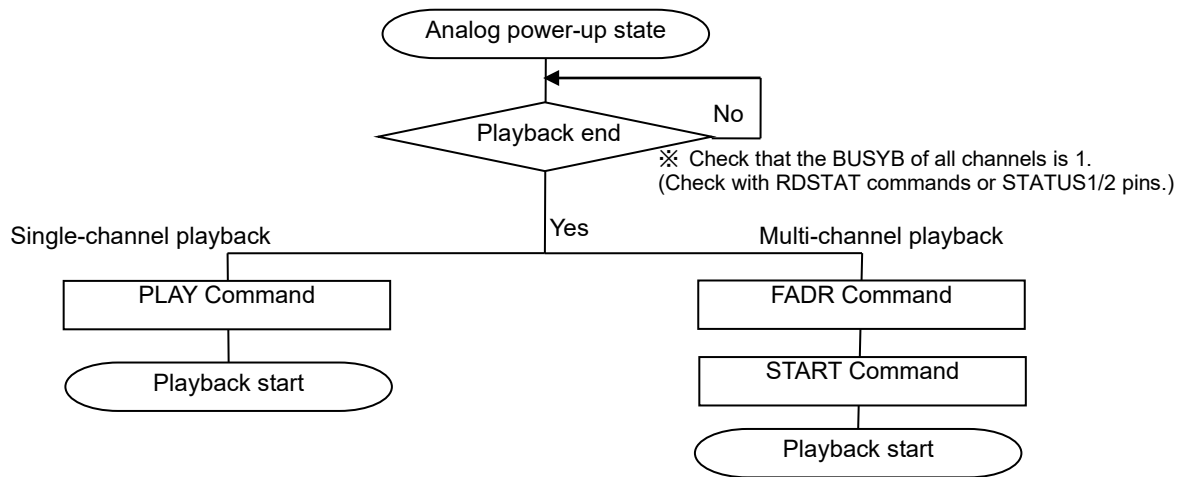

● Playback stop flow

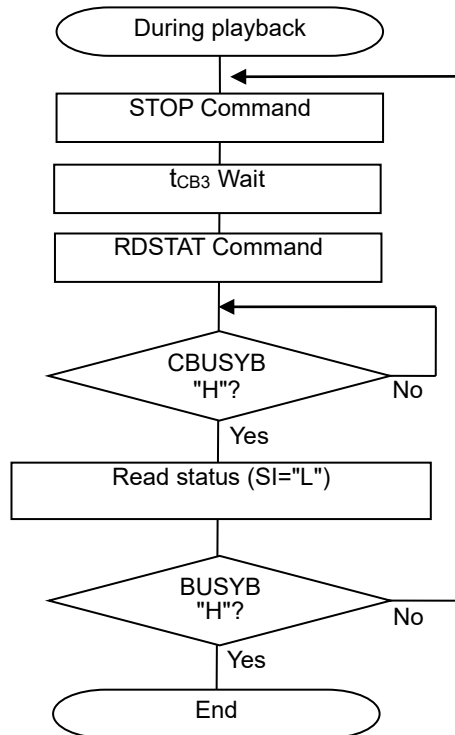

● Continuous playback flow

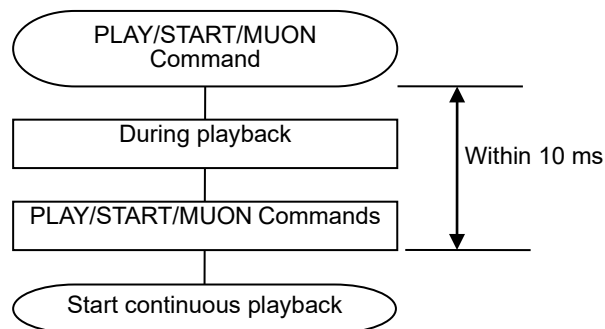

● Loop playback start flow

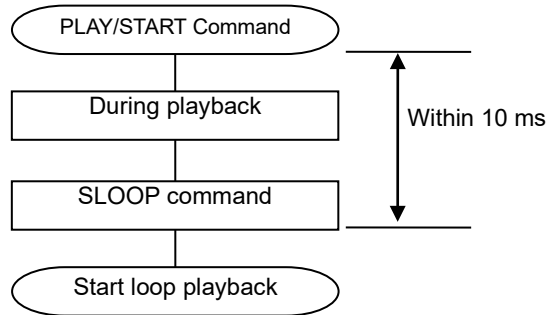

● Loop playback stop flow

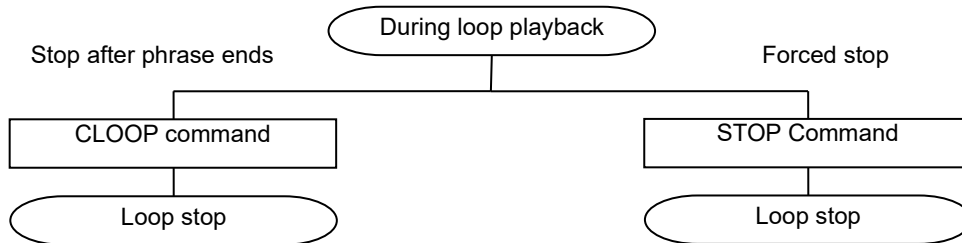

● Power-down flow

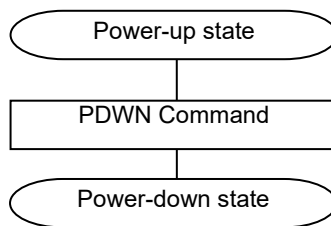

● Detailed flow of "Power-up → Playback → Power-down"

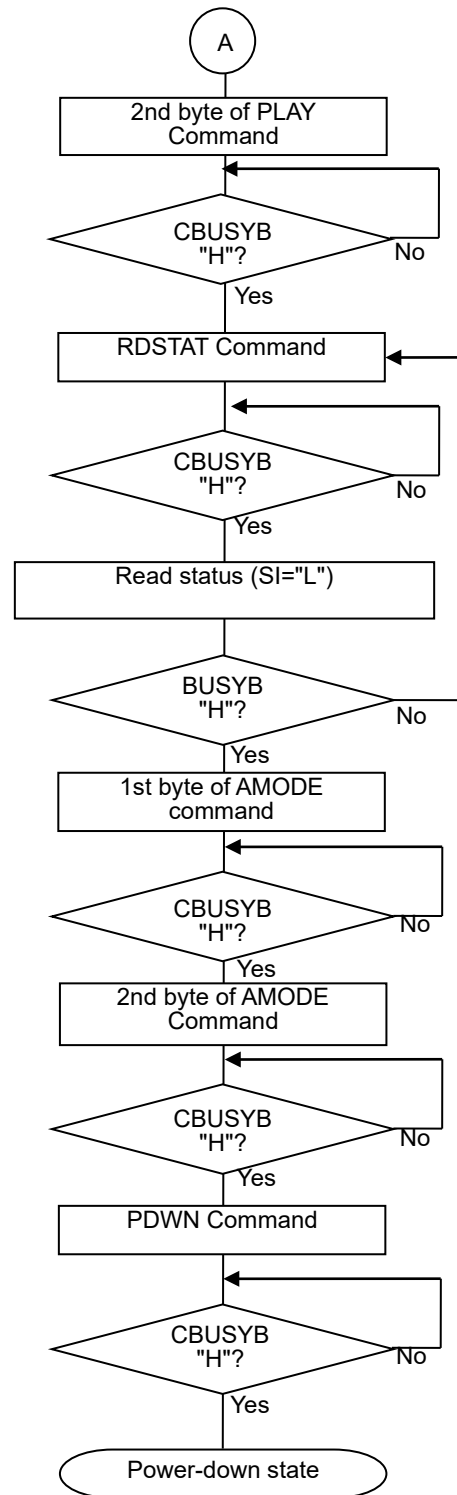
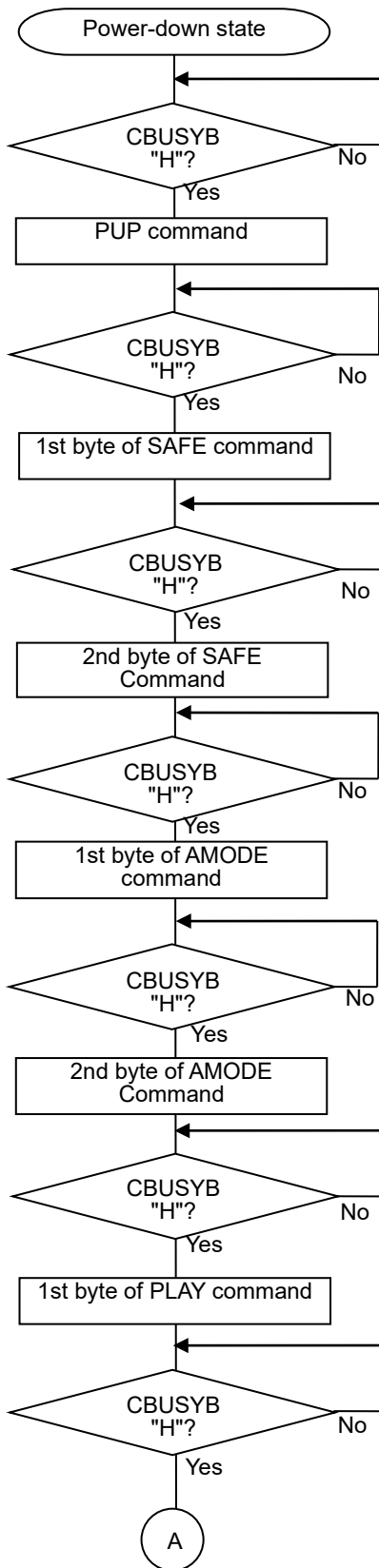

● Processing flow for speaker short detection

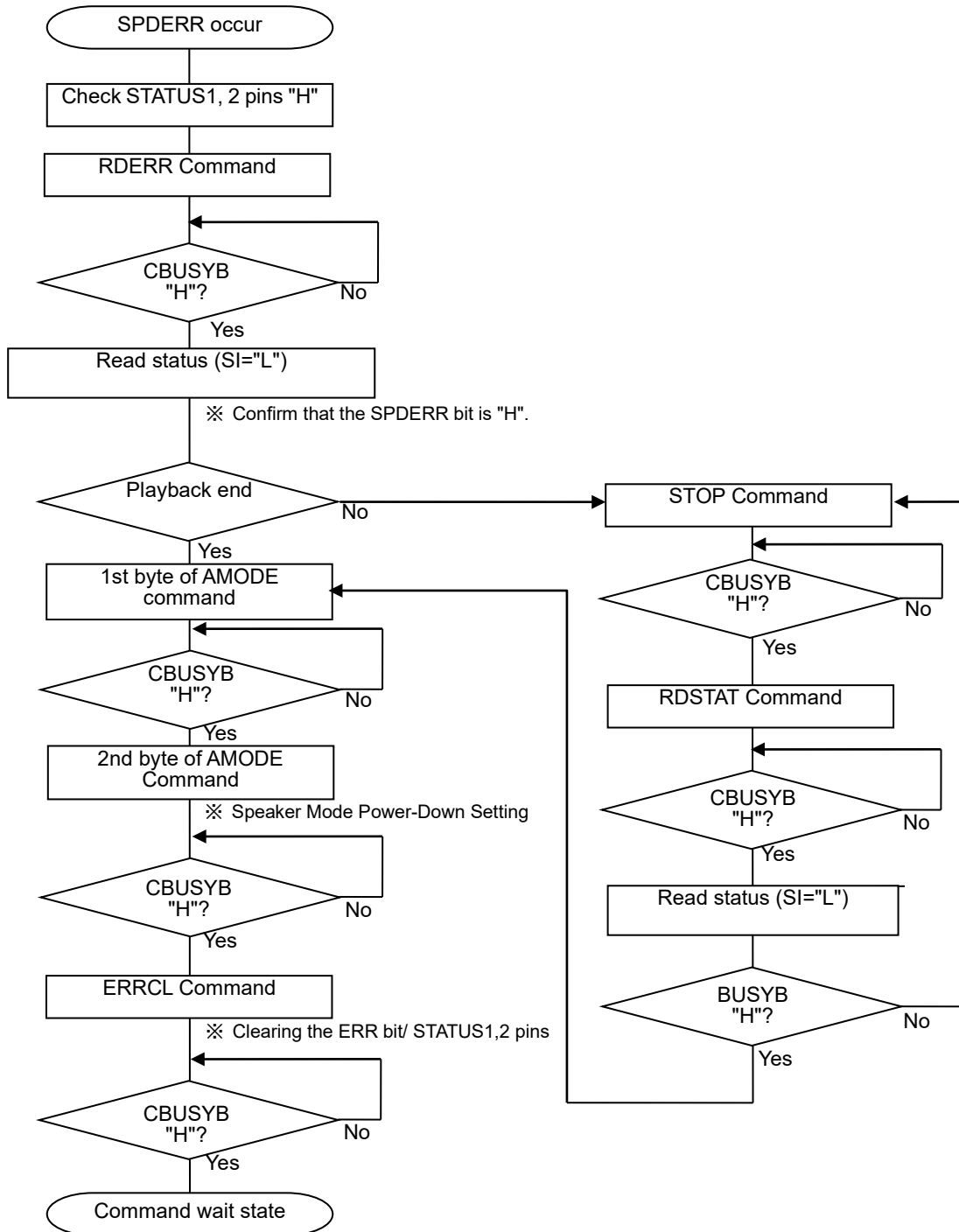

● 1-byte command input flow in two-times input mode

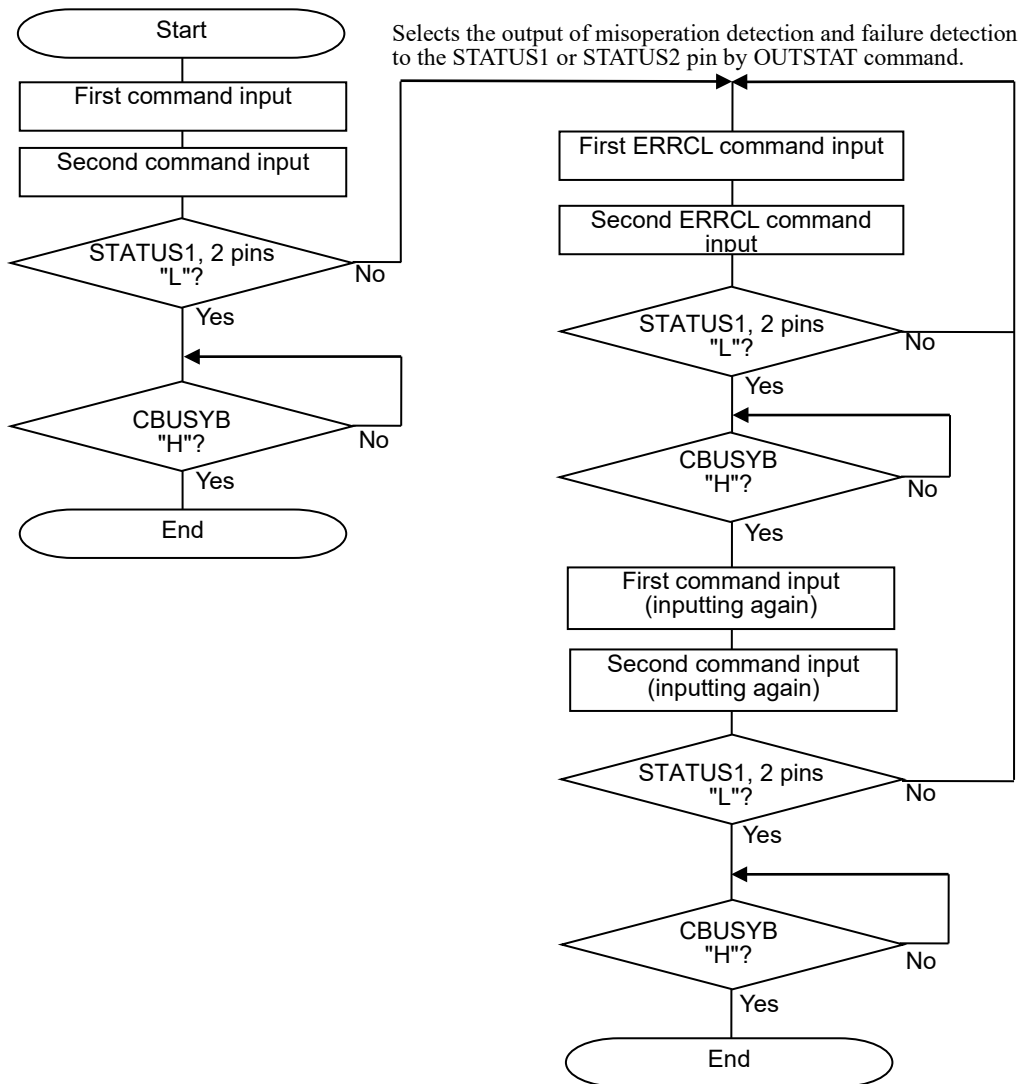

● 2-byte command input flow in two-times input mode

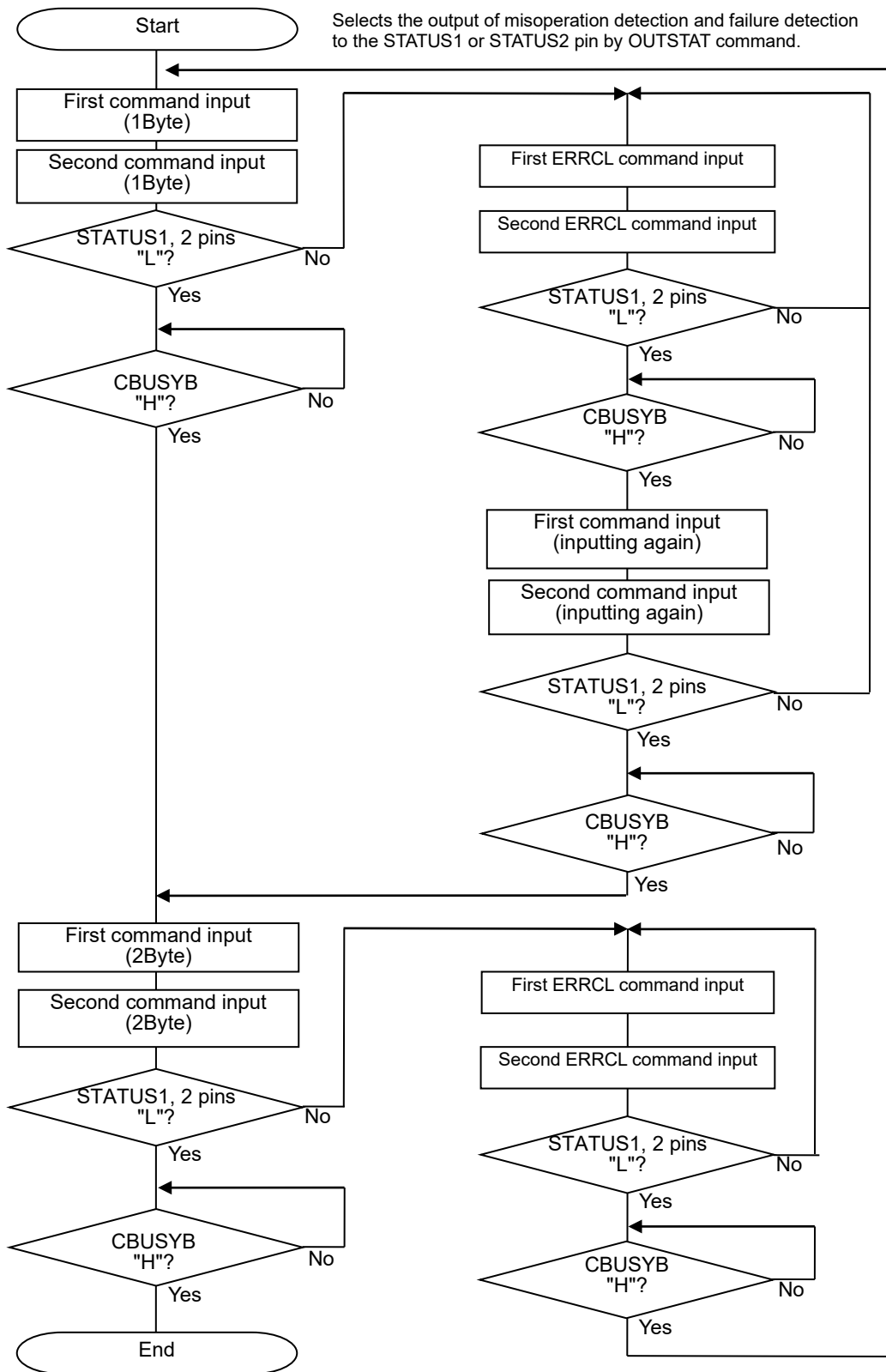

- Read flowchart in two-times input mode (Applies to RDSTAT, RDVER commands)

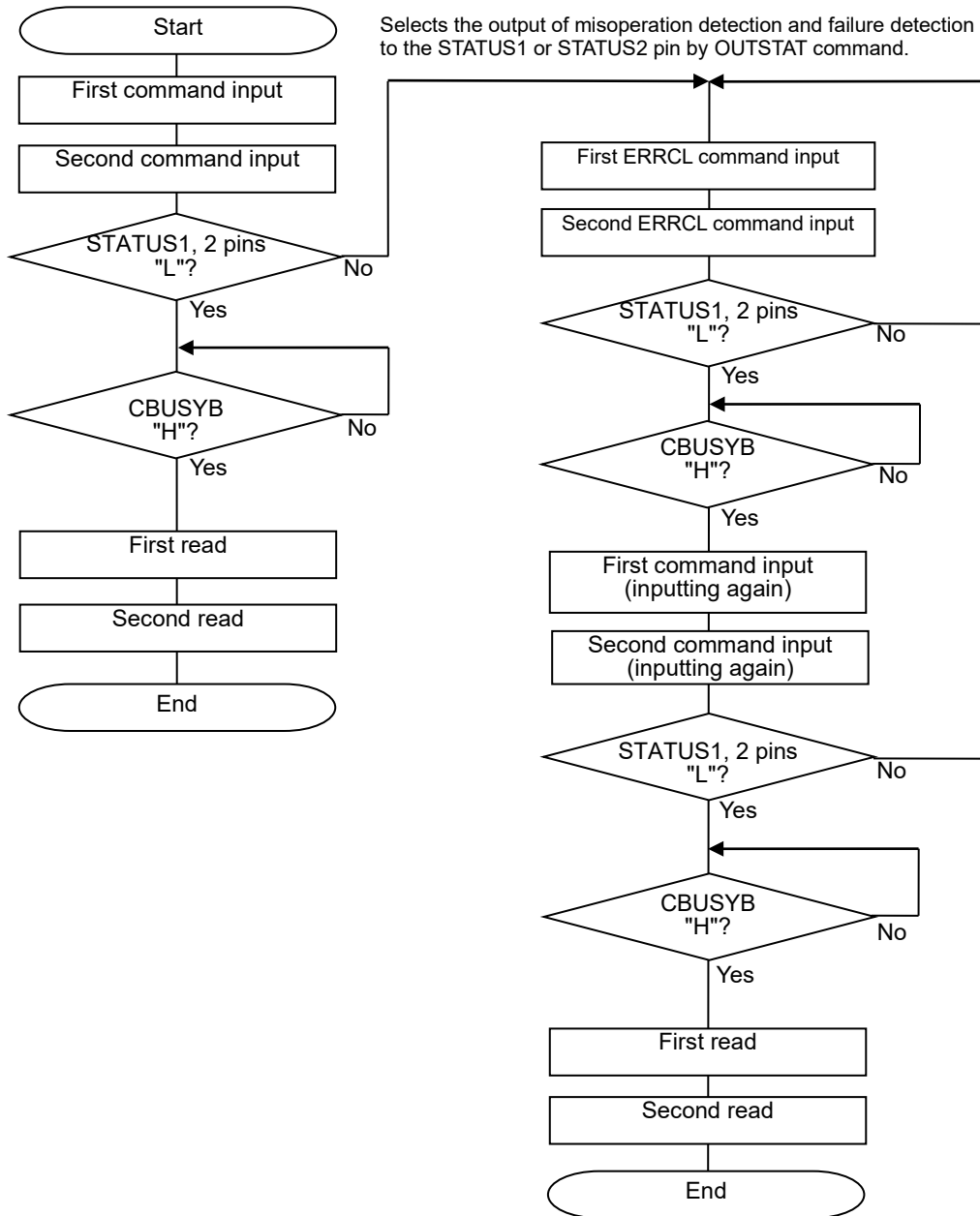

- Read flowchart in two-times input mode (Applies to RDERR command)

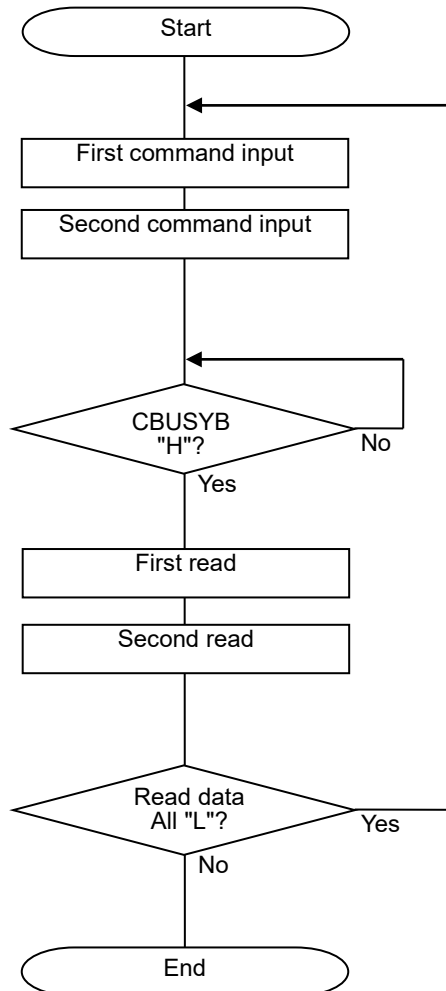

When the OUTSTAT command is used to select the misoperation detection and failure detection outputs and the STATUS1 or STATUS2 pin is "H", if all the read data is "L", the data cannot be read normally. Accordingly, read the data again.

- Read flow in the two-times input mode (applicable to the playback sound error detection command group)

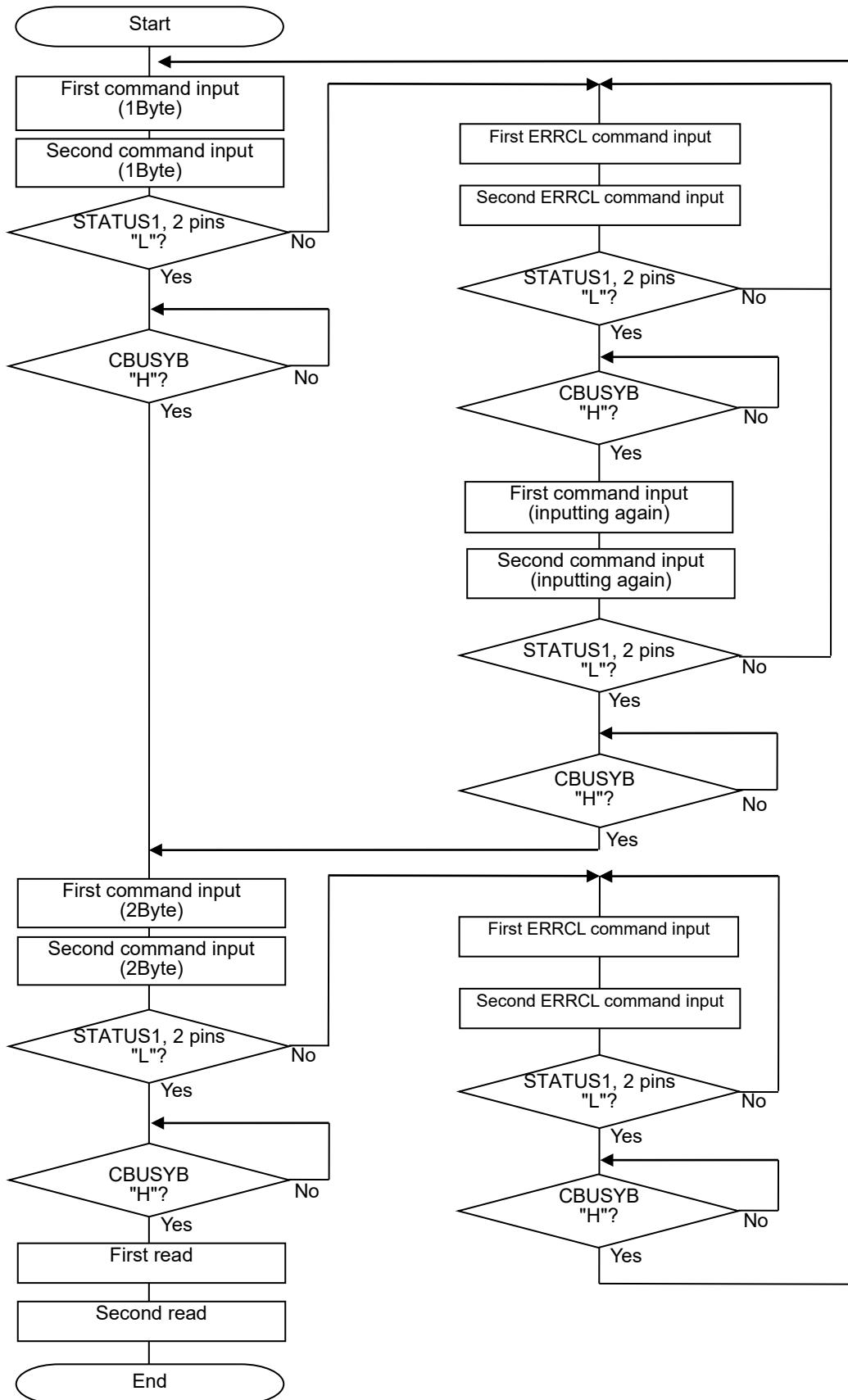

● SAI playback start flow

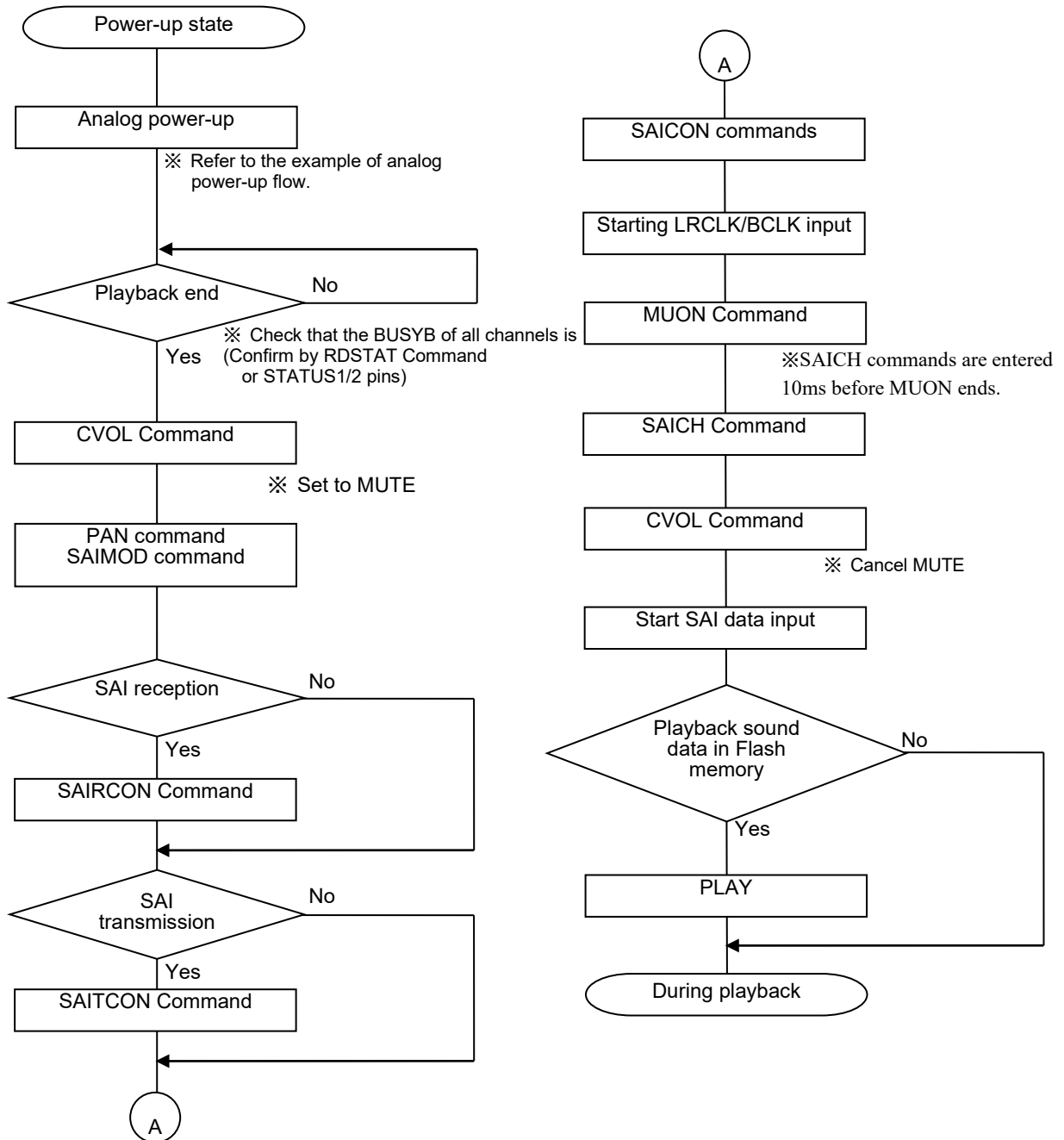

● SAI playback stop flow

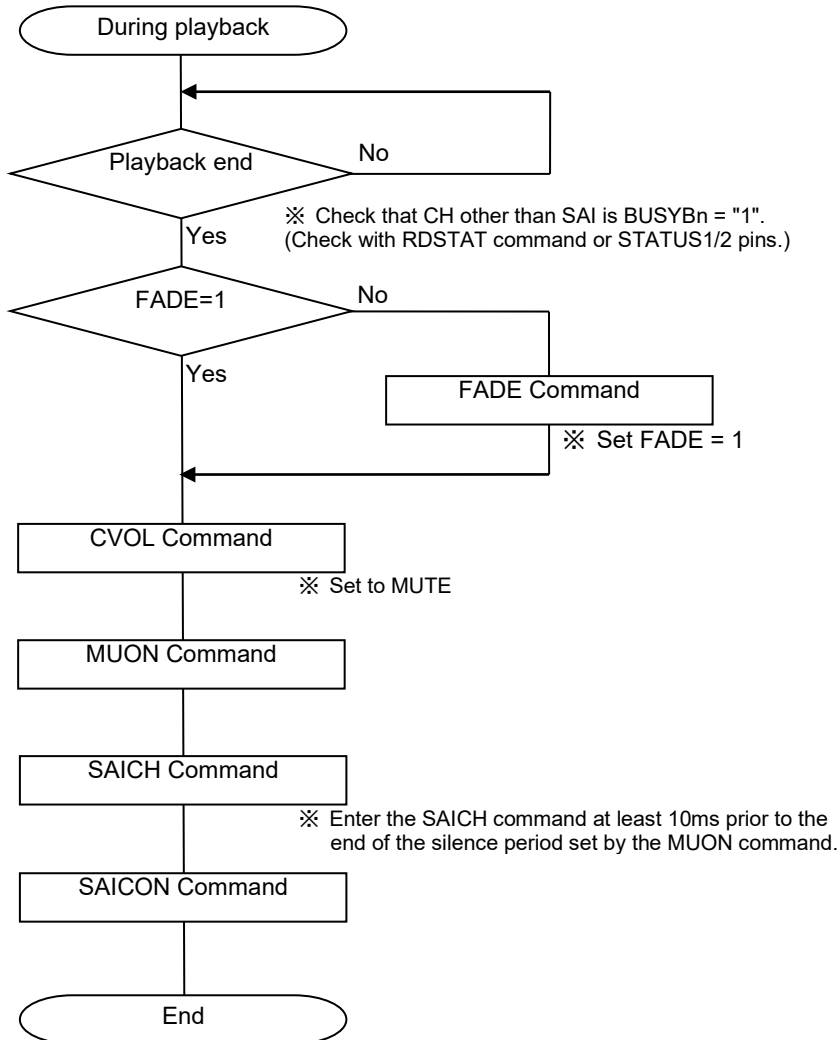

■ Peripheral circuit

● Handling of SG Pin

The SG pin is the signal ground for the built-in speaker amplifier. Connect a capacitor between this pin and the SPGND to prevent noises.

Pin	Symbol	Recommended Constant
SG	C9	0.1 μ F \pm 20%

● Handling of V_{DDL} Pin

The V_{DDL} pin is a power supply for the internal circuits. Connect a capacitor across the DGND to prevent noises and power supply fluctuations. Please place it near the LSI on the user board.

Pin	Symbol	Recommended Constant
V _{DDL}	C8	1 μ F \pm 20%

● Power wiring

The power supply of this LSI is divided into the following three power supplies.

- Digital power supply (DV_{DD}), digital GND (DGND)
- Speaker amplifier power supply (SPV_{DD}, SPOV_{DD}), Speaker amplifier GND (SPGND, SPOGND)
- Power supply for flash memory interface (IOV_{DD})

These power supplies can be used independently. However, use it in the condition of SPV_{DD}=SPOV_{DD} \geq DV_{DD}. When using the same power supply, branch it from the root of the power supply for wiring.

● Bypass capacitor

To improve noise-resistance, place the bypass capacitor close to the LSI on the user board, and shorten the wiring as short as possible without passing through the via.

Pin	Symbol	Recommended Constant
SPV _{DD} , SPOV _{DD}	C3	3.3 μ F \pm 20%
SPV _{DD} , SPOV _{DD}	C4	0.1 μ F \pm 20%
DV _{DD}	C5	3.3 μ F \pm 20%
DV _{DD}	C6	0.1 μ F \pm 20%
IOV _{DD}	C7	1 μ F \pm 20%

● Coupling capacitor

Insert when analog input from AIN pin.

Insert when using LOUT and SPP pins as line amplifier output.

Pin	Symbol	Recommended Constant
AIN	C10	0.1 μ F \pm 20%
LOUT/SPP	C11	0.1 μ F \pm 20%

■ Application Circuit

- Exclusive use of synchronous serial interfaces and I²C interface.

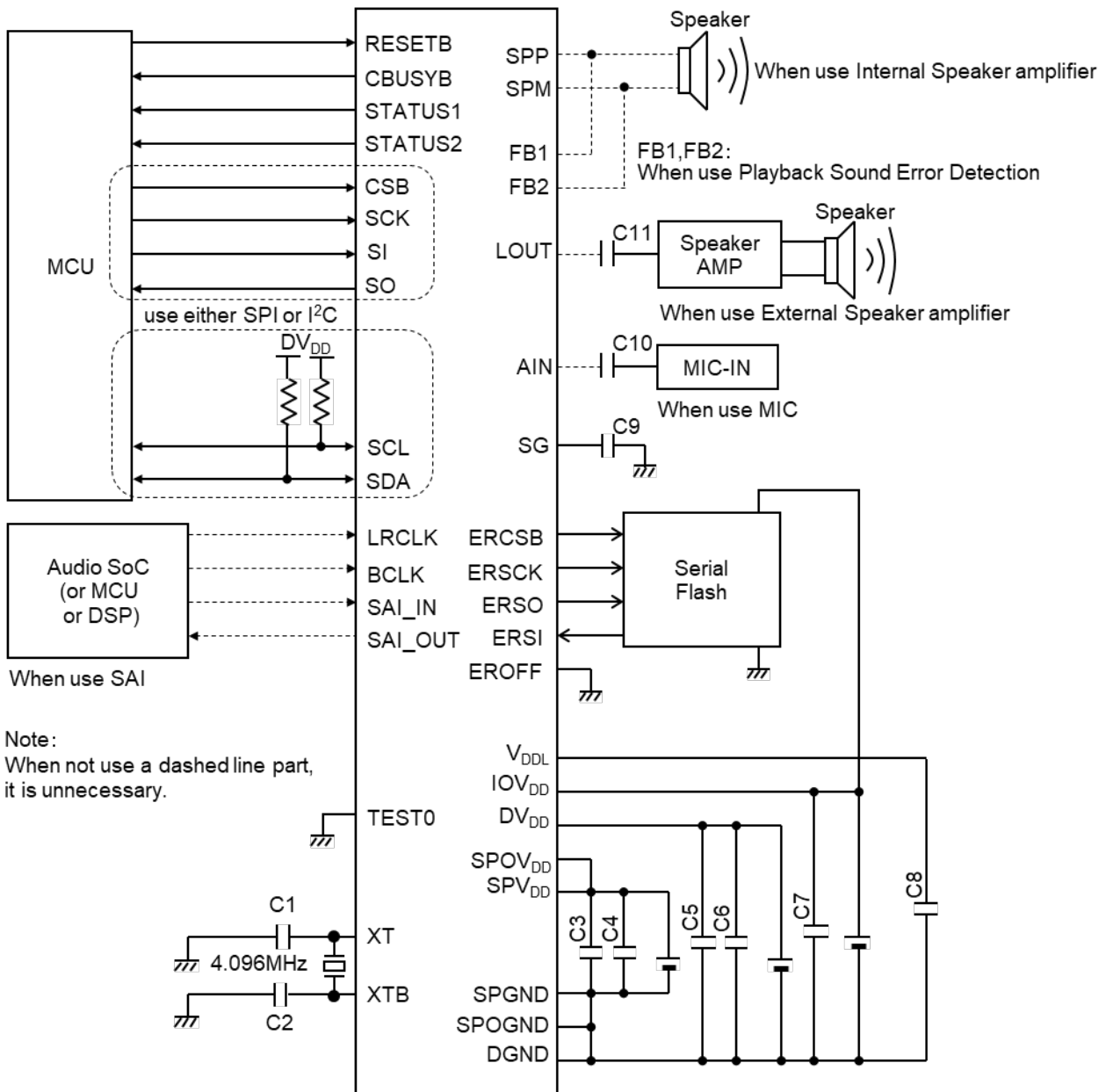

Please add necessary bypass capacitor to a power supply pin of the serial flash memory separately. The power supply for the ERCSB, ERSCK, ERSO, ERSI and EROFF pins is IOV_{DD}. If the crystal unit has a built-in capacitor, C1 and C2 are not needed.

■ Recommended ceramic resonator

Recommended ceramic resonators are shown below.

● MURATA Corporation

Frequency [Hz]	Product Name	Built-in load capacity [pF]
4M	CSTCR4M00G55B-R0	39
4.096M	CSTCR4M09G55B-R0	

■ RC4MHz characteristic

RC4MHz characteristic is as follows.

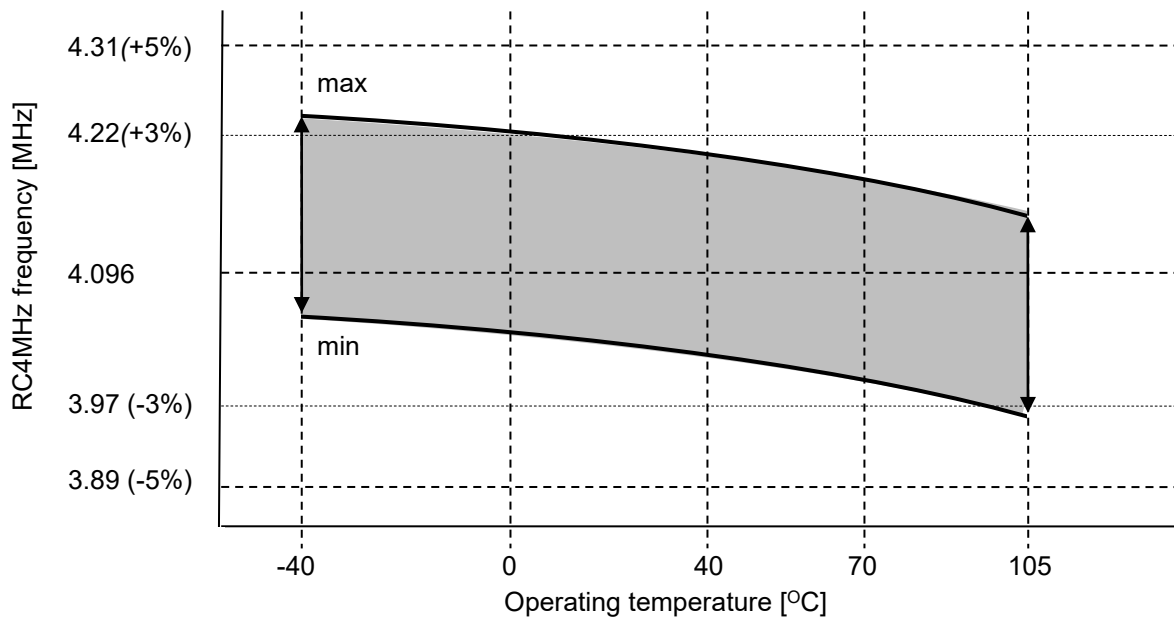

This graph is for reference only and does not guarantee the electrical characteristic.

■ Limitation on the operation time (Playback operating time)

This LSI operating temperature is 105°C (max). But the average ambient temperature at 1W playback (8ohm drive) for 10 years in the reliability design is Ta=65°C. (max (the package heat resistance θ_{ja} =32.1[°C/W]))

When this LSI operates 1W playback (8ohm drive) consecutively, the product life changes by the package temperature rise by the consumption. This limitation does not matter in the state that a speaker amplifier does not play.

The factors to decide the operation time (playback operating time) are the average ambient temperature (Ta), playback Watts (at the speaker drive mode), the soldering area ratio, and so on. In addition, the limitation on the operation time changes by the heat designs of the board.

■ Package Heat Resistance Value (Reference Value) (θ_{ja})

The following table is the package heat resistance value θ_{ja} (reference value). This value changes the condition of the board (size, layer number, and so on).

Board	θ_{ja}	Ψ_{jc}	Ψ_{jb}	Condition
JEDEC 4 layers *1 (W/L/t=76.2/114.5/1.6(mm))	32.1[°C/W]	0.70[°C/W]	12.2[°C/W]	Air cooling condition:No wind (0m/s)
JEDEC 2 layers *2 (W/L/t=76.2/114.5/1.6(mm))	38.3[°C/W]	0.74[°C/W]	13.0[°C/W]	the soldering area ratio*3:100%

*1 : The wiring density : 1st layer(Top) 60% / 2nd layer 100% / 3rd layer 100% / 4th layer(Bottom) 60%.

*2 : The wiring density : 1st layer(Top) 60% / 2nd layer(Bottom) 100%.

*3 : The soldering area ratio is the ratio that the heat sink area of this LSI and a land pattern on the board are soldered. 100% mean that the heat sink area of this LSI is completely soldered to the land pattern on the board. About the land pattern on the board, be sure to refer to the next clause (Package Dimensions).

The definition of each temperature is shown below.

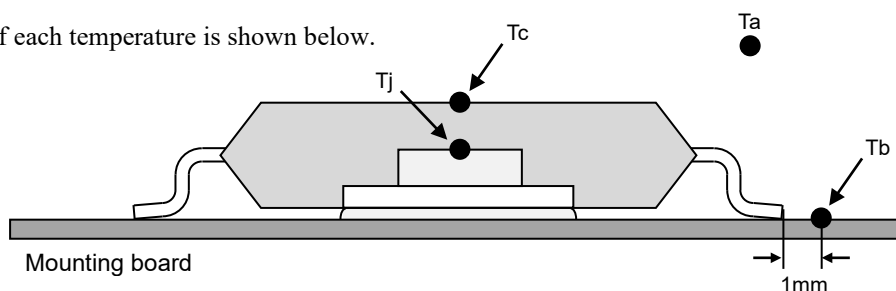

Take measures to dissipate heat on the mounting board so that the maximum junction temperature does not exceed 125 °C.

■ Package Dimensions

● ML22530TB

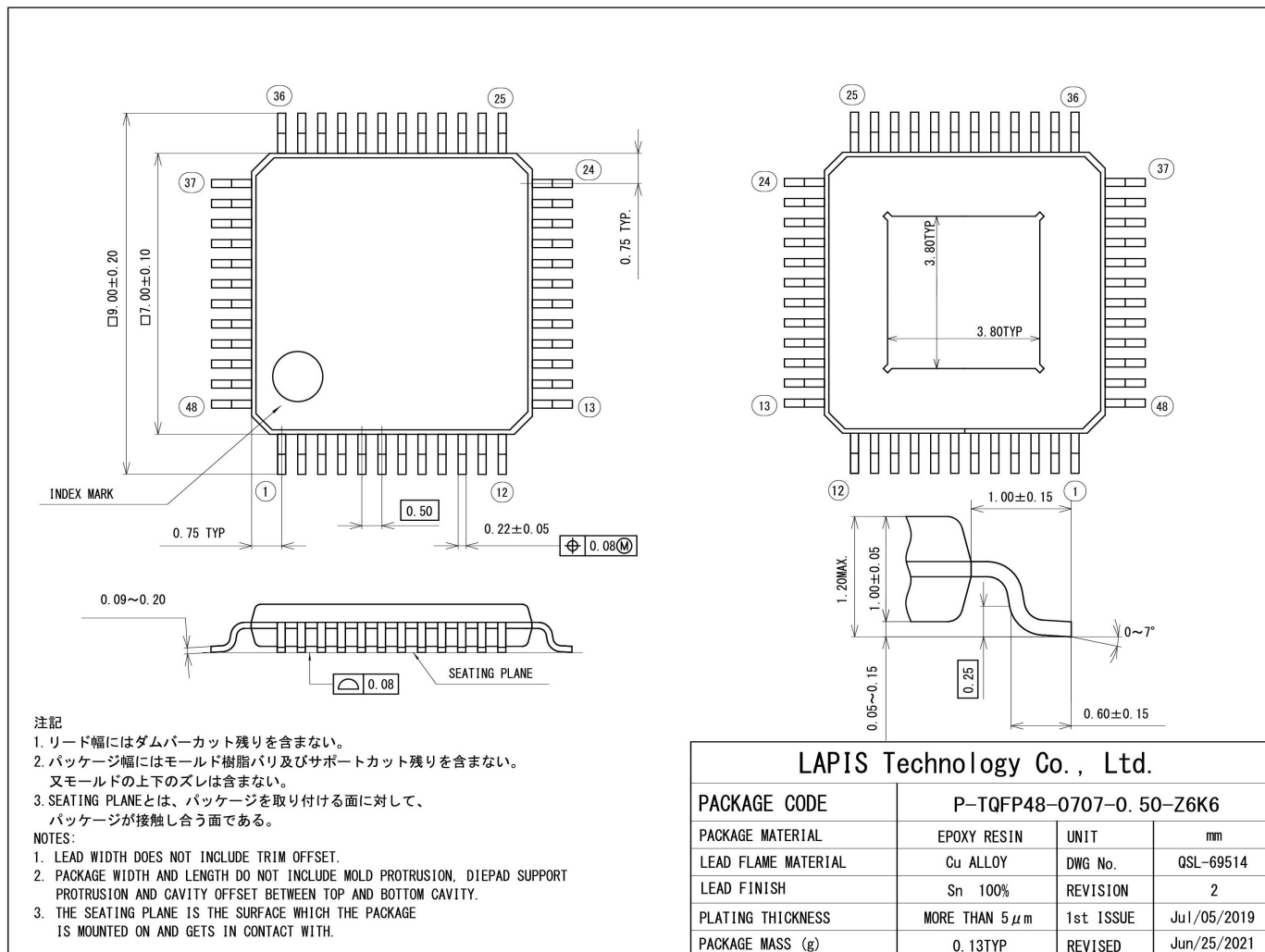

Notes for heat sink type Package

This LSI adopts a heat sink type package to raise a radiation of heat characteristic. Design a land pattern on the board that corresponds to the exposed area of the LSI die pad, and Solder the exposed die pad to the board. The potential of the board connected to the exposed die pad should be GND or open. A diagram of the range of terminal presence on the board (reference data) is shown on the next page.

半田付け部端子存在範囲図

Mounting area for package lead soldering to PC boards

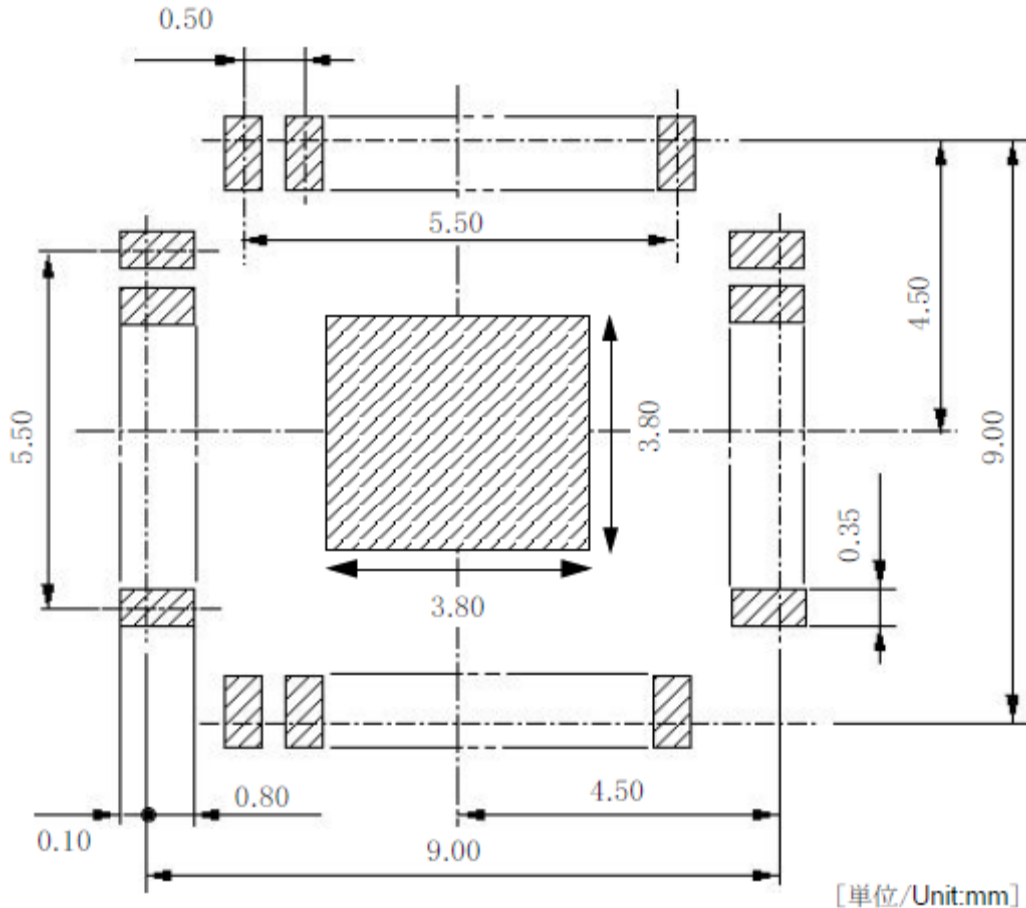

実装基板のフットパターンの設計の際には、実装の容易さ、接続の信頼性、配線の引き回し、半田ブリッジ発生のないことを十分考慮してください。

フットパターンの最適な設計は基板材質、使用する半田ペースト種類、厚み、半田付け方法などによって変わってきます。従って、本パッケージの端子の存在し得る範囲を「半田付け部端子存在範囲図」として示しますので、フットパターン設計の参考資料としてください。

When laying out PC boards, it is important to design the foot pattern so as to give consideration to ease of mounting, bonding, positioning of parts, reliability, wiring, and elimination of solder bridges.

The optimum design for the foot pattern varies with the materials of the substrate, the sort and thickness of used soldering paste, and the way of soldering. Therefore when laying out the foot pattern on the PC boards, refer to this figure which means the mounting area that the package leads are allowable for soldering to PC boards.

Notes for Mounting the Surface Mount Type Package

The surface mount type packages are very susceptible to heat in reflow mounting and humidity absorbed in storage. Therefore, before you perform reflow mounting, contact a ROHM sales office for the product name, package name, pin number, package code and desired mounting conditions (reflow method, temperature and times).

■ Differences from Existing Speech Synthesis LSIs (ML22Q553/ML22594)

Parameter		ML22Q553	ML22594	ML22530
MCU command interface		Clock synchronous serial (1 channel)	←	Clock Synchronous serial I ² C (2 channels)
Serial Audio Interface (SAI)		-	←	Yes
Clock frequency		4.096MHz (Built-in crystal oscillation circuit)	←	4.096MHz (crystal oscillation circuit/built-in RC oscillation)
Memory capacity	Built	4Mbits (flash memory)	6Mbits(mask rom)	-
	External	-	Up to 128Mbits	←
Flash memory rewrite function		JTAG Interface	-	MCU command interface (clock synchronous serial) *1
Sound function	Speech synthesis algorithm	HQ-ADPCM 8-bit non-linear PCM 8bit straight PCM 16-bit straight PCM	←	HQ-ADPCM 4bit ADPCM2 8-bit non-linear PCM 8bit straight PCM 16-bit straight PCM
	Sampling frequency (kHz)	6.4/12.8/25.6 8.0/16.0/32.0 12.0/24.0/48.0	←	6.4/12.8/25.6 8.0/16.0/32.0 10.7/21.3 11.025/22.05/44.1 12.0/24.0/48.0
	Simultaneous sounding function (Mixing-function)	4 channels	←	←
	Maximum number of phrases	1024	←	4096
	Edit ROM function	Yes	←	←
	Silence insertion function	20ms to 1024ms (4ms step)	←	←
	Repeat function	Yes	←	←
	Playback sound and SAI Mixing functions		-	←
Low-pass filter		FIR type interpolation filter	←	←
D/A converter		Voltage type 16-bit	←	←
Speaker amplifier (Class AB)		1.0W@8Ω (SPV _{DD} =5V)	←	←
Volume adjustment function	Digital	32 levels	←	128 levels
	Analog	50 levels	←	16 levels
	Fade function	-	←	Yes
External analog input		Yes	←	←
Failure detection function	Clock error detection	-	←	Yes
	Playback sound error detection	-	←	Yes
	Power supply voltage detection	Yes	←	-
	Thermal detection	Yes	←	←
	Speaker pin ground fault detection *2	Yes	←	←
	Speaker pin short detection *2	Yes	←	←
	Speaker disconnection detection	-	←	Yes
Power-supply voltage		DV _{DD} =SPV _{DD} =4.5 to 5.5V	DV _{DD} =SPV _{DD} =4.5 to 5.5V IOV _{DD} =2.7V to 5.5V	DV _{DD} =2.7 to 5.5V SPV _{DD} =SPOV _{DD} ≥DV _{DD} IOV _{DD} =2.7V to 5.5V
Operating temperature		-40 to 105°C	←	←
Package		30-pin SSOP	←	48-pin TQFP

*1 Controlling EROFF pin can prohibit the serial flash memory interface and can rewrite the serial flash memory by connecting flash wrighter.

*2 The ground fault detection and short-circuit detection functions can be used when the SPV_{DD} is 4.5V or higher.

■ Speech LSI Utility Setting Items

Set the following items on the Speech LSI Utility.

Item	Description
Protection code for flash memory access	Set any 8-bit data. <ul style="list-style-type: none"> • 0x69: Flash memory cannot be accessed by the FDIRECT command. • Other than 0x69: Accessing the flash memory is enabled when the protection unlock data entered by the FDIRECT command matches the data.
Master clock selection	Select master clock(Source clock oscillation). <ul style="list-style-type: none"> • RC (RC oscillation) • Xtal (Crystal or ceramic resonator)
Master clock frequency	Set the master clock frequency to F_{osc} . <ul style="list-style-type: none"> • 4.096 : 4.096MHz setting • 4.000 : 4.000MHz setting
Number of phrases used	Select the number of phrases from the following <ul style="list-style-type: none"> • 4096 • 3072 • 2048 • 1024
Sound ROM information	Set any 8-bit data. Read by RDVER command
Class D amplifier output format	Output format selection <ul style="list-style-type: none"> • Half-wave mode • Full wave mode is not supported.
WDT counter, RST counter WDTERR or RSTERR processing at overflow	Select the processing to be performed when an overflow occurs. <ul style="list-style-type: none"> • Hold current state • Transition to the state after PUP command input
WDT counter, RST counter WDTERR or RSTERR overflow time	Select the overflow time from the following. <ul style="list-style-type: none"> • 125ms • 500ms • 2s • 4s

Refer to the Speech LSI Utility User's Manual for more information.

■ Check lists

This check list has notes to frequently overlooked or misunderstood hardware features of the LSI. Check each note listed up chapter by chapter while coding the program or evaluating it using the LSI.

■ Feature

- [] *1 Mixing with SAI is limited by the sampling frequency. Refer to the "Function description".
- [] *2 The operating time of the speaker amplifier may be limited depending on the average ambient temperature (Ta) used.

■ Pin Description

- [] (SCL pin) When using an I²C, be sure to insert a pull-up resistor between DV_{DD} pin.
- [] (SCL pin) Accessing with synchronous serial Interface at the same time is prohibited.
- [] (SDA pin) When using an I²C, be sure to insert a pull-up resistor between DV_{DD} pin.
- [] (SDA pin) Accessing with synchronous serial Interface at the same time is prohibited.
- [] (CSB pin) Accessing with I²C slave interfaces at the same time is prohibited.
- [] (SCK pin) Accessing with I²C slave interfaces at the same time is prohibited.
- [] (SI pin) Accessing with I²C slave interfaces at the same time is prohibited.
- [] (SO pin) Accessing with I²C slave interfaces at the same time is prohibited.
- [] (EROFF pin) Set this pin to "L" during playback operation using serial flash memory.
- [] (EROFF pin) Set this bit to "H" for onboard rewriting.
- [] (IOV_{DD} pin) Connect to DV_{DD} pin even when not using serial flash memory interface.
- [] (IOV_{DD} pin) Connect a bypass capacitor between this pin and the DGND pin.
- [] (XTB pin) When using a resonator, connect it as close as possible.
- [] (XTB pin) Leave it open when not in use.
- [] (XT pin) To use an external clock, input from this pin. Delete the capacitor when a crystal or ceramic resonator is connected.
- [] (XT pin) When using a resonator, connect it as close as possible.
- [] (XT pin) Leave it open when not in use.
- [] (DV_{DD} pin) Connect a bypass capacitor between this pin and the DGND pin.
- [] (V_{DDL} pin) Connect a capacitor between this pin and DGND pin as close as possible.
- [] (SG pin) Connect a capacitor between this pin and SPGND pin.
- [] (SPV_{DD} pin) Connect a bypass capacitor between this pin and the SPGND pin.
- [] (SPOV_{DD} pin) Set it at the same potential as the SPV_{DD}.
- [] (SPOGND pin) Set it at the same potential as the SPGND.
- [] (RESETB pin) At power-on, input an "L" level to this pin. After the power supply voltage stabilizes, set this pin to an "H" level.
- [] (TEST0 pin) Fix to the DGND.
- [] (CBUSYB pin) Be sure to input a command with this pin at an "H" level.
- [] (N.C. pin) Unused pin. Leave open.

■ Termination of Unused Pins

- [] Confirm the recommended termination of unused pins in this chapter.

■ Electrical characteristics

● Recommended operating conditions

- [] *1 Be sure to $SPV_{DD} = SPOV_{DD} \geq DV_{DD}$.

■Function description

●I²C interface (Slave)

- [] When I2C is used, be sure to connect a pull-up resistor between SCL and SDA pins and DV_{DD} pin.
 - ◆ Command flow when reading data
- [] The data to be read is updated by inputting RDSTAT/RDERR/RDVER command. Be sure to enter the RDSTAT/RDERR/RDVER command before reading the internal status.

●SAI(Serial Audio Interface)

- [] To use SAI, use AMODE commands to place the SAI into the analog power-up status.

●Mixing function

◆ Restrictions when using Serial Audio Interface(SAI)

- [] When the serial audio interface (SAI) is used, there are some limitations to the maximum number of mixing and playable channels depending on the sampling frequency.
- [] When mixing at the sampling frequencies of 8.0/16.0/32.0kHz with using Serial Audio Interface(SAI), HQ-ADPCM cannot be used.

◆ Waveform clamp precautions for mixing

- [] If the clamp is known to be generated in advance, adjust the volume of each channel by CVOL and PAN commands.

◆ Different sampling frequency mixing algorithm

- [] It is not possible to perform channel mixing by a different sampling frequency group. Note that when channel synthesis is performed on a sampling frequency group other than the selected sampling frequency group, playback will be faster or slower.

●Misoperation detection and failure detection functions

◆ SPP pin and SPM pin short detection

- [] After inputting SAFE command, start the analog power-up operation by AMODE command within 10ms.

◆ Flash memory error detection

- [] If the error bit (ROMERR) is set to "1" after the PUP command and before the PLAY command or START command starts playback, this LSI may have error at the time of start. In such cases, initialize this LSI by moving the LSI to the power-down mode by resetting the LSI by the RESETB pin or by using PDWN command.

◆ Detects the stop of clock input from a crystal resonator or ceramic resonator

- [] If the RDERR command (first byte) is inputted before the crystal or ceramic resonator stops and switches to RC oscillation (about 500us), the CBUSYB pin will remain "L". Therefore, read the command after the CBUSYB pin becomes "H".
- [] When the crystal resonator or the ceramic resonator stops and switches to RC oscillation, playback may become abnormal. Therefore, after confirming that the error bit (OSCERR) is "1", enter STOP command to stop playback.

◆ Detects disconnection/short circuit of LRCLK

- [] *5 The unit does not recover even if a normal LRCLK is input after stopping playback. Enter MUON command →SAICH command after inputting a normal LRCLK.

◆ Detects disconnection/short circuit of SAI_IN

- [] When OUTEN is set to "1" and INEN is set to "0" by the SAICON command, the SAI_IN input is disabled. Therefore, set SAIINEN to "0".

◆ Mixing number error detection

- [] When using the serial audio interface (SAI), the sampling frequency limits the maximum number of mixings and playable channels.

■Timing chart

●Common

◆ Power-on timing

- [] Start up in the order of DVDD, SPVDD and IOVDD or DVDD, IOVDD and SPVDD.
- [] Be sure to input "L" to the RESETB pin before inputting the first command after power-on.
- [] Be sure to enter "L" at the RESETB pin when the DVDD is below the (recommended) operating voltage range.

◆ Power-off timing

- [] Shut down in the order of IOVDD, SPVDD, and DVDD or SPVDD, IOVDD, and DVDD.
- [] Shut down each power supply after changing to the power down status with PDWN commands.

- Clock synchronous serial
 - ◆ Change volume timing by AVOL command
 - [] Speaker amplifier volume setting by AVOL commands is valid only when Class AB speaker amplifier is used. When a Class D speaker amplifier is used, the setting value is ignored and +0.0dB is selected.
 - ◆ Continuous playback timing by PLAY command
 - [] When making continuous playbacks, input the PLAY command for the next phrases within the specified time period (tcm) after the NCR of the corresponding channel changes to "H" level.
 - [] When the playback is not continuous, input the PLAY command for the next phrases after confirming the playback is completed by RDSTAT command and etc.
 - ◆ Continuous playback timing by START command
 - [] When making continuous playbacks, send the START command for the next phrases within the specified time period (tcm) after the NCR of the corresponding channel changes to "H" level.
 - [] When the playback is not continuous, input the START command for the next phrases after confirming the playback is completed by RDSTAT command, etc.
 - ◆ Continuous playback timing by MUON command
 - [] When making continuous playbacks, input the MUON/PLAY/START command for the next phrases within 10ms (tcm) after the NCR of the corresponding channel changes to "H" level. When the playback is not continuous, input the MUON/PLAY/START command for the next phrases after confirming the playback is completed by RDSTAT command and etc.
 - ◆ Repeat playback setting/release timing by SLOOP/CLOOP command
 - [] The SLOOP command is valid only during playback. After the PLAY command is input, input the SLOOP command within the specified period (tcm) after the NCR of the corresponding channel becomes "H" level.
- I2C Interface (Slave)
 - ◆ Change volume timing by AVOL command
 - [] Speaker amplifier volume setting by AVOL commands is valid only when Class AB speaker amplifier is used. When a Class D speaker amplifier is used, the setting value is ignored and +0.0dB is selected.
 - ◆ Continuous playback timing by PLAY command
 - [] When making continuous playbacks, input the PLAY command for the next phrases within the specified time period (tcm) after the NCR of the corresponding channel changes to "H" level.
 - [] When the playback is not continuous, input the PLAY command for the next phrases after confirming the playback is completed by RDSTAT command and etc.
 - ◆ Continuous playback timing by START command
 - [] When making continuous playbacks, send the START command for the next phrases within the specified time period (tcm) after the NCR of the corresponding channel changes to "H" level.
 - [] When the playback is not continuous, input the START command for the next phrases after confirming the playback is completed by RDSTAT command, etc.
 - ◆ Continuous playback timing by MUON command
 - [] When making continuous playbacks, input the MUON/PLAY/START command for the next phrases within 10ms (tcm) after the NCR of the corresponding channel changes to "H" level. When the playback is not continuous, input the MUON/PLAY/START command for the next phrases after confirming the playback is completed by RDSTAT command and etc.
 - ◆ Repeat playback setting/release timing by SLOOP/CLOOP command
 - [] The SLOOP command is valid only during playback. After the PLAY command is input, input the SLOOP command within the specified period (tcm) after the NCR of the corresponding channel becomes "H" level.

■ Command

- Command list
 - [] Do not enter command that is not described in this manual. Enter the command with the CBUSYB "H".
- Description of Command Functions
 - ◆ PUP command
 - [] Even if two-times input modes are used for the I²C interface, one-time input is used for the slave address input. If the slave address matches, ACK is returned. If the slave address does not match, NACK is returned. The command is input two-times.

- ◆ AMODE command
 - [] To perform power-down under a setting condition that differs from the power-up condition of the analog unit, set the AMODE command to set the power-down condition again.
 - [] To power up the analog part, set the CVOL command to 00h (initial value) and then enter the AMODE command.
 - [] When using analog mixing from the AIN pin, set DAMP = "0" (Class AB amplifier is used). In this LSI, select DAMP = "0" (Class AB amplifier is used).
 - [] Input the sound signals to the AIN pin after CBUSYB pin becomes "H" by the AMODE command.
 - [] When using a Class D amplifier with speaker amplifier outputs, set it to the power-up state (AEN1/AEN0= "01") or the power-down state (AEN1/AEN0= "00"). If DAMP = "1" is selected, do not set AEN1= "1".
- ◆ AVOL command
 - [] AV5-AV2=1h and 2h are prohibited.
- ◆ FDIRECT command
 - [] The FDIRECT command controls accesses to the flash memory using the clock-synchronous serial interface. Input the command after inputting the PUP command.
 - [] Do not enter this command because this command is ignored when this command is entered from the I²C interface.
 - [] To cancel the flash memory access mode, insert a reset (RESETB = "L") and conduct initialization or turn off the power supply.
- ◆ START command
 - [] Be sure to specify one of the channels for the channel setting (CH0-CH3). Do not input it to "0" (all "0") with specifying nothing. If it is input with specifying nothing (all "0"), the command is ignored.
- ◆ STOP command
 - [] The STOP command can be input regardless of the status of the NCR during playback operation. However, following the elapse of CBUSYB "L" level output time 3 (tCB3), input the next command after confirming that the BUSYB signal becomes "H". If the BUSYB signal does not become "H", enter the STOP command again.
 - [] Be sure to specify one of the channels for the channel setting (CH0-CH3). Do not input it to "0" (all "0") with specifying nothing. If it is input with specifying nothing (all "0"), the command is ignored.
- ◆ MUON command
 - [] Set the silence setting (M7-M0) to 04h or more (tmu>=20ms).
 - [] Be sure to specify one of the channels for the channel setting (CH0-CH3). Do not input it to "0" (all "0") with specifying nothing. If it is input with specifying nothing (all "0"), the command is ignored.
- ◆ SLOOP command
 - [] Be sure to specify one of the channels for the channel setting (CH0-CH3). Do not input it to "0" (all "0") with specifying nothing. If it is input with specifying nothing (all "0"), the command is ignored.
- ◆ CLOOP command
 - [] Be sure to specify one of the channels for the channel setting (CH0-CH3). Do not input it to "0" (all "0") with specifying nothing. If it is input with specifying nothing (all "0"), the command is ignored.
- ◆ CVOL command
 - [] Be sure to specify one of the channels for the channel setting (CH0-CH3). When multiple channels are specified, the volume of the specified channels is set. Do not input it to "0" (all "0") with specifying nothing. If it is input with specifying nothing (all "0"), the command is ignored.
- ◆ RDSTAT commnad
 - [] When reading the status of the second byte after command input, set the SI pin to "L".
- ◆ RDVER command
 - [] When reading the status of the second byte after command input, set the SI pin to "L".
- ◆ RDERR command
 - [] When reading the status of the second byte after command input, set the SI pin to "L".
 - [] If the outputs of misoperation detection and failure detection are selected by OUTSTAT command, and the read data is all "L" even though STATUS1 or STATUS2 pin is "H", the read data cannot be read normally. Be sure to read it again.
- ◆ SAFE command
 - [] The initial value is the operation stop state ("0"). When this bit is set to "1", operation starts.
 - [] *1 Do not set WDTEN and RSTEN to "1" at the same time. If these bits are set to "1" at the same time, only the RSTEN bit is set to "1".

◆ SAICH command

- [] Set these bits when channels other than SAIs are not playing back (BUSYBn is "1").
- [] If you want to set LEN="0" and REN="1" with LEN="1" and REN="0", set LEN="0" and REN="1" after setting LEN=REN="0".
- [] Start the LRCLK/BCLK input after entering the SAICON command. Subsequently, enter the MUON command and then the SAICH command.
- [] After entering the MUON command, enter the SAICH command at least 10ms prior to the end of the silence period set by the MUON command.
- [] Use a channel that is not played back by SAICH as the playback channel set by MUON commands. To mix with ROM playback, use a channel for ROM playback.

◆ SAICON command

- [] Set this bit when the Lch-side serial audio interface (SAI) operation of the SAICH command is stopped (LEN="0") and the Rch-side serial audio interface (SAI) operation is stopped (REN="0"). If either LEN or REN is set to "1", the entered SAICON command is ignored.

◆ SAITCON command

- [] Use the same format as that of SAIRCON command. Set this bit when the Lch-side serial audio interface (SAI) operation of the SAICH command is stopped (LEN="0") and the Rch-side serial audio interface (SAI) operation is stopped (REN="0"). If either LEN or REN is set to "1", the entered SAITCON command is ignored.

◆ SAIRCON command

- [] Use the same format as that of SAITCON command. Set this bit when the Lch-side serial audio interface (SAI) operation of the SAICH command is stopped (LEN="0") and the Rch-side serial audio interface (SAI) operation is stopped (REN="0"). If either LEN or REN is set to "1", the entered SAIRCON command is ignored.

◆ SAIMOD command

- [] Set this bit when the Lch-side serial audio interface (SAI) operation of the SAICH command is stopped (LEN="0") and the Rch-side serial audio interface (SAI) operation is stopped (REN="0"). If either LEN or REN is set to "1", the entered SAIMOD command is ignored.

■ Peripheral circuit

- Handling of SG Pin / ● Handling of V_{DDL} Pin / ● Power wiring / ● Bypass capacitor / ● Coupling capacitor

- [] Confirm the recommended values and precautions in this chapter.

■ Package Dimensions

- [] Confirm "Notes for heat sink type Package" and "Notes for Mounting the Surface Mount Type Package" in this chapter.

■ Speech LSI Utility Setting Items

- [] Confirm setting items of "Speech LSI Utility" in this chapter.

■ Revision history

Document No.	Date	Page		Description
		Previous edition	Current edition	
FEDL22530-01	Apr 24, 2020	-	-	Formal 1st edition.
FEDL22530-02	Jul 2, 2020	2	2	Added "DV _{DD} , SPV _{DD} /SPOV _{DD} and IOV _{DD} can be set independently. (SPV _{DD} =SPOV _{DD} ≥DV _{DD})" to the description of power-supply voltage.
		4	4	Changed description of SCL pin to "be sure to insert a pull-up resistor between DV _{DD} pin."
		21	21	
		163	163	
		170	170	
		171	171	
		12	12	Added "**2" to the standard value of I _{DDO} and I _{DDS} of DC characteristics.
		20	20	Added "Accessing with I ² C slave interface at the same time is prohibited." to Clock Synchronous Serial Interface.
		21	21	Added "Accessing with clock synchronous serial interface at the same time is prohibited." to Clock Synchronous Serial Interface.
		24	24	Added description to SAI(Serial Audio Interface).
		27	27	Added definition of compression rate.
		34	34	Changed description of command error detection. (Not a change in product specifications.)
		38	38	Changed description of watchdog timer overflow detection. (Not a change in product specifications.)
		40	40	Changed description of RST counter overflow detection. (Not a change in product specifications.)
		44	44	Added description of mixing number error detection.
		46	46	Added a method to return from flash memory access mode to normal mode.
		49	49	Changed t _{EFHL} and t _{ELH} of Serial flash memory interface timing.
		107	107	Changed description of DAMP bit of AMODE command. (Not a change in product specifications.)
		108	108	Changed description of POP bit of AMODE command. (Not a change in product specifications.)
108	108	Changed description of table of AEN1, AEN0 and POP bit, of AMODE command. (Not a change in product specifications.)		
130	130	Changed description of OSCEN bit of SAFE command. (Not a change in product specifications.)		
162	162	Added attention of voltage setting of SPV _{DD} /SPOV _{DD} and DV _{DD} for power wiring.		
162	162	Added C11 to the coupling capacitor.		
164	164	Changed notation of recommended ceramic resonator. (Not a recommended product change.)		
FEDL22530-03	Oct 1,2020	11	11	Addition of terminals to V _{OH3} (Before change) ERSO (After change) ERCSB / ERSCK / ERSO

Document No.	Date	Page		Description
		Previous edition	Current edition	
FEDL22530-03	Oct 1,2020	11	-	I _{IH4} deleted
		12	12	Change current consumption I _{DDO} value during playback operation (Before change) Max 55mA (After change) Typ 25mA,Max 45mA
		14	14	When AMODE command is input CBUSYB "L" level output time t _{PUPA2} value change (Before change) min 72ms,typ 74ms,max 76ms (After change) min 71ms,typ 73ms,max 75ms
		14	14	When AMODE command is input CBUSYB "L" level output time t _{PUPA3} value change (Before change) min 32ms,typ 34ms,max 36ms (After change) min 31ms,typ 33ms,max 35ms
		14	14	When AMODE command is input CBUSYB "L" level output time t _{PDA1} value change (Before change) min 106ms,typ 108ms,max 110ms (After change) min 100ms,typ 102ms,max 104ms
		14	14	When AMODE command is input CBUSYB "L" level output time t _{PDA2} value change (Before change) min 143ms,typ 145ms,max 147ms (After change) min 142ms,typ 144ms,max 146ms
		14	14	When AMODE command is input CBUSYB "L" level output time t _{PDA3} value change (Before change) min 103ms,typ 105ms,max 107ms (After change) min 102ms,typ 104ms,max 106ms
		105	105	Added WVDIFEDATH and WVDIFEDATL to the command list
		139	-	SCMODE command description deleted
		140	-	WVDIFTH command description deleted
		159	-	Deleted playback sound error detection start flow
		160	-	Deleted AIN disconnection detection mode setting flow
		161	-	Deleted AIN disconnection detection mode stop flow
		161	-	Deleted Playback sound error detection stop flow
FEDL22530-04	Dec 10,2020	4	4	Added attention of ERCSB,ERSCK and ERSO output initial condition.
		9	9	LOUT equivalent circuit power supply change (Before change) SPOV _{DD} (After change) SPV _{DD}
		15	15	Added t _{DOH} to the AC Characteristics (Clock Synchronous Serial Interface).
		20	20	Changed Clock Synchronous Serial Interface timing wave form.
		50	50	Changed Clock Synchronous Serial Interface timing wave form.
		107	107	Changed description of power down timing with POP noise noise suppression. (Not a change in product specifications.)

Document No.	Date	Page		Description
		Previous edition	Current edition	
FEDL22530-05	Jul 20,2021	8	8	Classification F I/O Equivalent Circuit change (Before change) Input/Output (After change) Output
		8	8	Classification G I/O Equivalent Circuit change (Before change) Input/Output (After change) Output
		8	8	Classification H I/O Equivalent Circuit change (Before change) Input/Output (After change) Input
		16	16	AC characteristics I2C interface First mode Wording deleted
		42	42	Change the timing chart when the OSCEN bit of the SAFE command continues to be "1" (Before change) After ERRCL, when oscillation is stopped, the STATUSn pin and OSCERR maintain "L". (After change) After ERRCL, when oscillation is stopped, the STATUSn pin and OSCERR become "H".
		158	158	Added explanation about capacitors for crystal oscillators
FEDL22530-06	Jul 10,2023	161	161	(Before change) Be sure to design the land pattern corresponding to the heat sink area of the LSI on a board, and solder each other. The heat sink area of the LSI solder open or GND on the board. (After change) Design a land pattern on the board that corresponds to the exposed area of the LSI die pad, and Solder the exposed die pad to the board. The potential of the board connected to the exposed die pad should be GND or open. A diagram of the range of terminal presence on the board (reference data) is shown on the next page.
FEDL22530-07	Feb 9,2024	-	3	Added application information.
		2	3	Changed shipping form to table format.
		173	174	Revised the Note.

Notes

- 1) When using LAPIS Technology Products, refer to the latest product information and ensure that usage conditions (absolute maximum ratings*1, recommended operating conditions, etc.) are within the ranges specified. LAPIS Technology disclaims any and all liability for any malfunctions, failure or accident arising out of or in connection with the use of LAPIS Technology Products outside of such usage conditions specified ranges, or without observing precautions. Even if it is used within such usage conditions specified ranges, semiconductors can break down and malfunction due to various factors. Therefore, in order to prevent personal injury, fire or the other damage from break down or malfunction of LAPIS Technology Products, please take safety at your own risk measures such as complying with the derating characteristics, implementing redundant and fire prevention designs, and utilizing backups and fail-safe procedures.
*1: Absolute maximum ratings: a limit value that must not be exceeded even momentarily.
- 2) The Products specified in this document are not designed to be radiation tolerant.
- 3) Descriptions of circuits, software and other related information in this document are provided only to illustrate the standard operation of semiconductor products and application examples. You are fully responsible for the incorporation or any other use of the circuits, software, and information in the design of your product or system. And the peripheral conditions must be taken into account when designing circuits for mass production. LAPIS Technology disclaims any and all liability for any losses and damages incurred by you or third parties arising from the use of these circuits, software, and other related information.
- 4) No license, expressly or implied, is granted hereby under any intellectual property rights or other rights of LAPIS Technology or any third party with respect to LAPIS Technology Products or the information contained in this document (including but not limited to, the Product data, drawings, charts, programs, algorithms, and application examples, etc.). Therefore, LAPIS Technology shall have no responsibility whatsoever for any dispute, concerning such rights owned by third parties, arising out of the use of such technical information.
- 5) LAPIS Technology intends our Products to be used in a way indicated in this document. Please be sure to contact a ROHM sales office if you consider the use of our Products in different way from original use indicated in this document. For use of our Products in medical systems, please be sure to contact a LAPIS Technology representative and must obtain written agreement. Do not use our Products in applications which may directly cause injuries to human life, and which require extremely high reliability, such as aerospace equipment, nuclear power control systems, and submarine repeaters, etc. LAPIS Technology disclaims any and all liability for any losses and damages incurred by you or third parties arising by using the Product for purposes not intended by us without our prior written consent.
- 6) All information contained in this document is subject to change for the purpose of improvement, etc. without any prior notice. Before purchasing or using LAPIS Technology Products, please confirm the latest information with a ROHM sales office. LAPIS Technology has used reasonable care to ensure the accuracy of the information contained in this document, however, LAPIS Technology shall have no responsibility for any damages, expenses or losses arising from inaccuracy or errors of such information.
- 7) Please use the Products in accordance with any applicable environmental laws and regulations, such as the RoHS Directive. LAPIS Technology shall have no responsibility for any damages or losses resulting non-compliance with any applicable laws or regulations.
- 8) When providing our Products and technologies contained in this document to other countries, you must abide by the procedures and provisions stipulated in all applicable export laws and regulations, including without limitation the US Export Administration Regulations and the Foreign Exchange and Foreign Trade Act.
- 9) Please contact a ROHM sales office if you have any questions regarding the information contained in this document or LAPIS Technology's Products.
- 10) This document, in part or in whole, may not be reprinted or reproduced without prior consent of LAPIS Technology.

(Note) "LAPIS Technology" as used in this document means LAPIS Technology Co., Ltd.

Copyright 2020 – 2024 LAPIS Technology Co., Ltd

LAPIS Technology Co., Ltd.

2-4-8 Shinyokohama, Kouhoku-ku, Yokohama 222-8575, Japan

<https://www.lapis-tech.com/en/>