

uEASE

User's manual

The 3rd edition

NOTICE

No copying or reproduction of this document, in part or in whole, is permitted without the consent of LAPIS Semiconductor Co., Ltd.

The content specified herein is subject to change for improvement without notice.

The content specified herein is for the purpose of introducing LAPIS Semiconductor's products (hereinafter "Products"). If you wish to use any such Product, please be sure to refer to the specifications, which can be obtained from LAPIS Semiconductor upon request.

Examples of application circuits, circuit constants and any other information contained herein illustrate the standard usage and operations of the Products. The peripheral conditions must be taken into account when designing circuits for mass production.

Great care was taken in ensuring the accuracy of the information specified in this document. However, should you incur any damage arising from any inaccuracy or misprint of such information, LAPIS Semiconductor shall bear no responsibility for such damage.

The technical information specified herein is intended only to show the typical functions of and examples of application circuits for the Products. LAPIS Semiconductor does not grant you, explicitly or implicitly, any license to use or exercise intellectual property or other rights held by LAPIS Semiconductor and other parties. LAPIS Semiconductor shall bear no responsibility whatsoever for any dispute arising from the use of such technical information.

The Products specified in this document are intended to be used with general-use electronic equipment or devices (such as audio visual equipment, office-automation equipment, communication devices, electronic appliances and amusement devices).

The Products specified in this document are not designed to be radiation tolerant.

While LAPIS Semiconductor always makes efforts to enhance the quality and reliability of its Products, a Product may fail or malfunction for a variety of reasons.

Please be sure to implement in your equipment using the Products safety measures to guard against the possibility of physical injury, fire or any other damage caused in the event of the failure of any Product, such as derating, redundancy, fire control and fail-safe designs. LAPIS Semiconductor shall bear no responsibility whatsoever for your use of any Product outside of the prescribed scope or not in accordance with the instruction manual.

The Products are not designed or manufactured to be used with any equipment, device or system which requires an extremely high level of reliability the failure or malfunction of which may result in a direct threat to human life or create a risk of human injury (such as a medical instrument, transportation equipment, aerospace machinery, nuclear-reactor controller, fuel-controller or other safety device). LAPIS Semiconductor shall bear no responsibility in any way for use of any of the Products for the above special purposes. If a Product is intended to be used for any such special purpose, please contact a ROHM sales representative before purchasing.

If you intend to export or ship overseas any Product or technology specified herein that may be controlled under the Foreign Exchange and the Foreign Trade Law, you will be required to obtain a license or permit under the Law.

Table of Contents

PREFACE	1
Product Inquiries	2
Using this Product Safely and Properly	3
Important Safety Notes	4
Notations	6
Terminology	7
1 OVERVIEW	8
1.1 About a product	9
1.2 Package components	10
1.3 External View	11
1.4 Operating condition	12
1.5 Requirements for user target board.....	13
1.5.1 Recommended circuitry of user target board for uEASE connection	14
2 GETTING STARTED	15
2.1 Setting up and Starting up	16
2.1.1 Procedure to Starting up	16
2.1.2 Procedure to disconnect	17
3 FUNCTION	18
3.1 Function	19
4 NOTES	21
4.1 Notes	22
4.1.1 About the environment.....	22
4.1.2 About flash programming.....	22
4.1.3 About cables	22

5	APPENDIX	23
5.1	Form information	24
5.1.1	uEASE.....	24
5.1.2	uEASE Interface Cable.....	24
5.1.3	USB Cable	24
5.2	External View of the uEASE interface cable	25

Preface



Product Inquiries

Thank you for purchasing the uEASE on-chip debug emulator. Please direct any comments or questions that you may have about this product to your nearest LAPIS Semiconductor representative.

Using this Product Safely and Properly

This User's Guide uses various labels and icons that serve as your guides to operating this product safely and properly so as to prevent death, personal injury, and property damage. The following table lists these labels and their definitions.

Labels

 Warning	<p>1. This label indicates precautions that, if ignored or otherwise not completely followed, could lead to death or serious personal injury.</p>
 Caution	<p>1. This label indicates precautions that, if ignored or otherwise not completely followed, could lead to personal injury or property damage.</p>

Icons



A triangular icon draws your attention to the presence of a hazard. The illustration inside the triangular frame indicates the nature of the hazard—in this example, an electrical shock hazard.









A circular icon with a solid background illustrates an action to be performed. The illustration inside this circle indicates this action—in this example, unplugging the power cord.









A circular icon with a crossbar indicates a prohibition. The illustration inside this circle indicates the prohibited action—in this example, disassembly.





Important Safety Notes

Please read this page before using the product.

 Warning	
<p>Use only the specified voltage. Using the wrong voltage risks fire and electrical shock.</p>	
<p>At the first signs of smoke, an unusual smell, or other problems, unplug the emulator and disconnect all external power cords. Continued use risks fire and electrical shock.</p>	
<p>Do not use the product in an environment exposing it to moisture or high humidity. Such exposure risks fire and electrical shock.</p>	
<p>Do not pile objects on top of the product. Such pressure risks fire and electrical shock.</p>	
<p>At the first signs of breakdown, immediately stop using the product, unplug the emulator, and disconnect all external power cords. Continued use risks fire and electrical shock.</p>	

 Caution	
<p>Do not use this product on an unstable or inclined base as it can fall or overturn, producing injury.</p>	
<p>Do not use this product in an environment exposing it to excessive vibration, strong magnetic fields, or corrosive gases. Such factors can loosen or even disconnect cable connectors, producing a breakdown.</p>	
<p>Do not use this product in an environment exposing it to temperatures outside the specified range, direct sunlight, or excessive dust. Such factors risk fire and breakdown.</p>	
<p>Use only the cables and other accessories provided. Using non-compatible parts risks fire and breakdown.</p>	
<p>Do not use the cables and other accessories provided with other systems. Such improper usage risks fire.</p>	

Please read this page before using the product.

 Caution	
<p>Do not exceed the rated input voltage for the user cable VDD pin. Doing so risks fire and breakdown.</p>	
<p>Always observe the specified order for turning equipment on and off. Using the incorrect order risks fire and breakdown.</p>	
<p>Always cut the power to the emulator before altering connections. Connection or disconnection with the power on risks fire and breakdown.</p>	
<p>Always cut the power to the emulator and the user application system before altering connections between the two. Connection or disconnection with the power on risks fire and breakdown.</p>	

Notations

This User's Guide uses the following labels for material that complements the main text.

- | | |
|----------------------|---|
| ■ Caution ■ | This notation introduces material requiring special attention. |
| ■ Reference ■ | This notation introduces related material found elsewhere in this User's Guide. |
| ■ Example ■ | This notation introduces an example illustrating the discussion. |
| (See Note n.) | This notation introduces a reference to a numbered note providing supplementary information lower on the same page. |
| ■ Note n ■ | This notation introduces a numbered note providing supplementary information. |

Terminology

The following table lists the terms used in this manual.

Term	Description
uEASE	Hardware of the on-chip debug emulator / Flash ROM writer for LAPIS Semiconductor 8-bit micro-controller.
DTU8 Debugger	Software, for Microsoft Windows, controls the uEASE as on-chip debug emulator.
FWuEASE Flash Writer host program	Software, for Microsoft Windows, controls the uEASE as a Flash ROM writer.
User Target board	Board on which microcontroller has embedded Flash ROM and/or On-chip-debug function is mounted.
Host PC	PC in which the DTU8 Debugger or FWuEASE Flash Writer host program, and the USB driver are installed.
USB cable	Cable used to connect the uEASE and a PC on which the FWuEASE Flash Writer host program operates.
uEASE interface cable	Interface cable for connecting the uEASE and a user target board.

y.

1 Overview

This chapter explains the outline of uEASE, the function, etc.

1.1 About a product

uEASE is a hardware that can be a protocol converter between PC based software and a LAPIS Semiconductor original low power microcontroller (here-in-after, called a target microcontroller) which has embedded low-voltage Flash ROM on a user target board.

Moreover, uEASE on-chip debug emulator can also work as a Flash ROM writer by replacing software development tools with the FWuEASE Flash Writer host program.

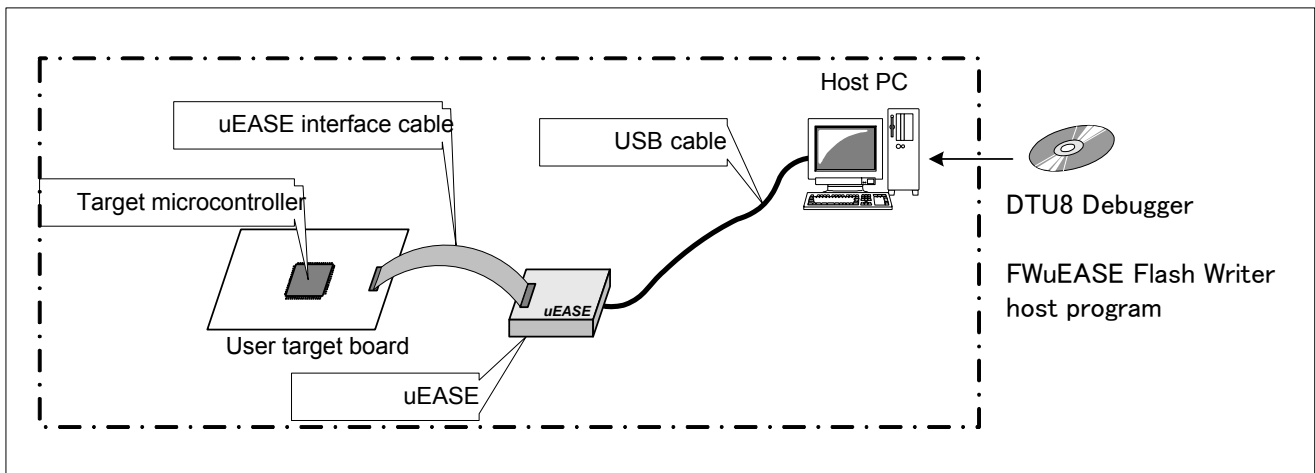

Fig 1-1 uEASE System configuration

1.2 Package components

The package contains the components listed below.

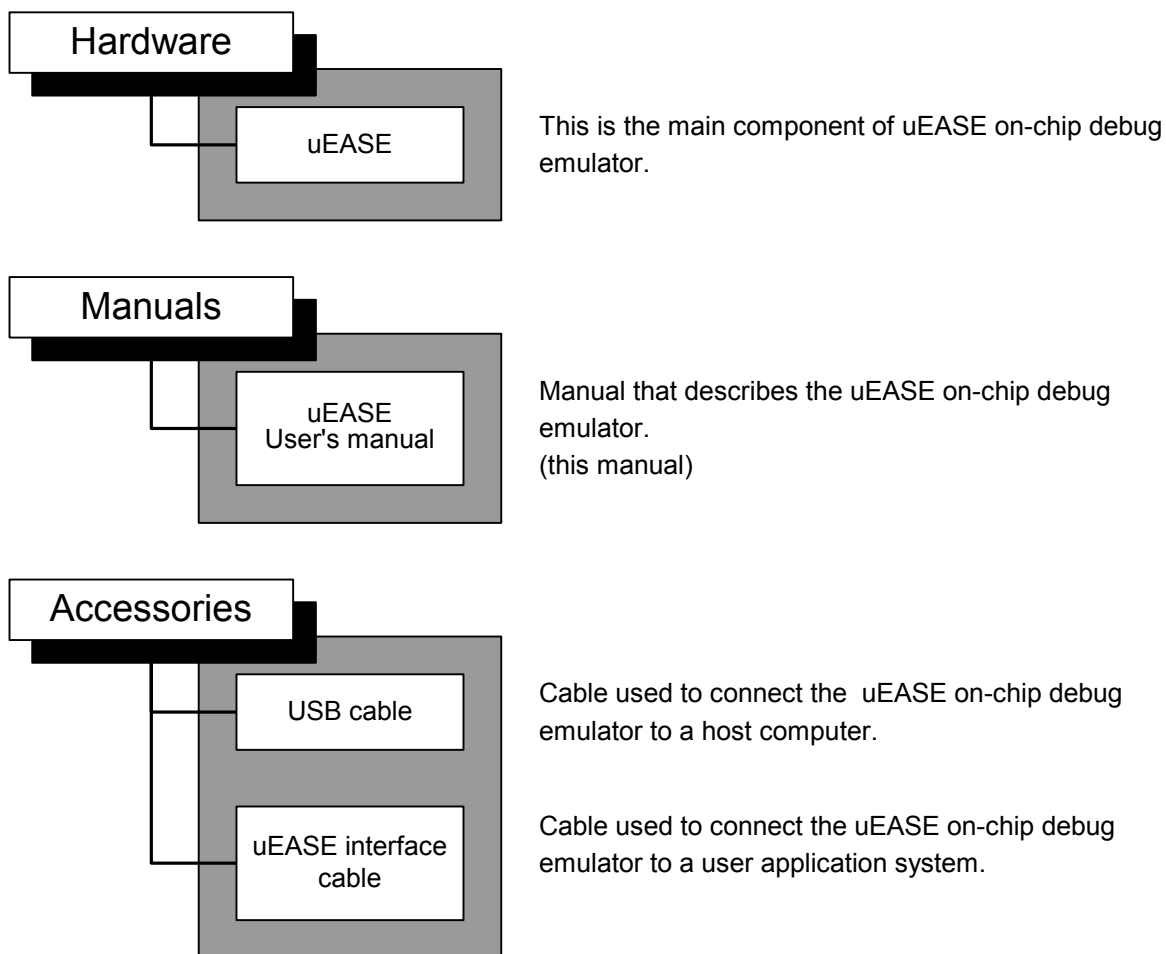

Fig 1-2 Package components of uEASE

1.3 External View

Below, the external view of uEASE and explanation of each part are indicated. The portion shown in the following sentences and within () shows the name printed by the case.

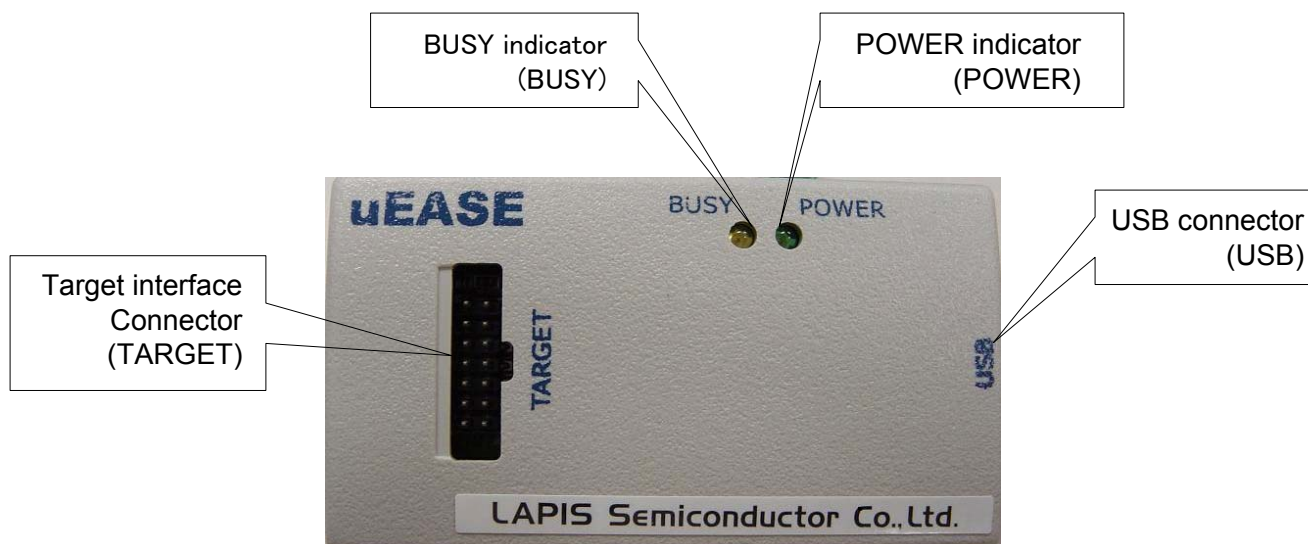

Fig 1-3 External view (Top View)

Target interface connector (TARGET)

: It is a connector for connecting a user target board with uEASE. An attached uEASE interface cable is connected.

USB connector (USB)

: It is a connector (Type-B mini) for connecting host PC with uEASE. It connects with an attached USB cable.

POWER indicator (POWER)

: It is LED which tells the state of uEASE. It switches on the light or blinks green.

Please refer to the 3.2nd clause "Function" for correspondence with the lighting state of an indicator, and the state of uEASE.

BUSY indicator (BUSY)

: It is LED which tells the state of uEASE. It switches on the light or blinks in yellow. Please refer to the 3.2nd clause "Function" for correspondence with the lighting state of an indicator, and the state of uEASE.

1.4 Operating condition

Please use the uEASE in the following conditions.

Operating condition	
Item	Description
Power supply.	A USB port on PC has to be capable to supply 5V, 500mA to uEASE
Ambient environment.	Temperature:5 to 40 (centigrade) Humidity: 30 to 80% (Non Condensingx)
The input voltage of the positive power supply for target microcontroller. (VTref)	1.55V to 5.5V

Please refer to the following documents for the operating environment of the software which works on host PC.

- DTU8 debugger user's manual
- FWuEASE Flash Writer host program user's manual

Please refer to the following document for the connection with your target microcontroller.

- uEASE connection manual ML610QXXX

When uEASE is used as an on-chip debugging emulator or a flash writer, the power supply supplied to a target microcomputer from uEASE is as follows.

Operating condition	
Item	Description
The output voltage of power supply for target microcontroller. (3.3VOUT)	3.3V(typ)/100mA(max)
The output voltage of the power supply for programming Flash ROM(Vpp)	8V(max)/10mA(max)
The output voltage of the positive power supply for internal logic(VDDL)	In programming Flash ROM : 2.80V(typ)/20mA(max) At operation usually : 1.45V(typ)/20mA(max)

- The power supply for target microcontroller (3.3VOUT) is outputted while the uEASE is in a debugging state.
- The power supply for programming Flash ROM (Vpp) is outputted while the uEASE is in programming FLASH ROM.
- The positive power supply for internal logic (VDDL) is outputted 1.45V while the uEASE is in debugging state, and it is outputted 2.80V while the uEASE is in programming FLASH ROM.

1.5 Requirements for user target board

The user target system linked to uEASE needs to satisfy the following requirements.

The requirements for a user target system	
Item	Description
Recommended interface socket for uEASE interface cable connector	Part Number : 7614-6002 Supplier : 3M
Positive power supply (VDD) voltage of target microcontroller	1.55V to 5.5V (Notes 1)
Consumption current (VTref)	10mA

uEASE uses the VDD power supply for generating the interface signals which is used for communication to the target microcontroller.

The maximum current of VDD power supply which consumed by uEASE is shown below.

uEASE VTref terminal consumption current (except for transient current)	
The VDD power supply voltage	Consumption current (max)
+5.5V	10mA
+3.3V	2mA

■ Notes 1■

Please use the VDD power supply of a target system by sufficient capacity in consideration of a part for the consumed current by uEASE.

■ Notes 2■

With uEASE, to program Flash ROM in a target microcontroller or to do debug by downloading your software into it, uEASE programs the Flash ROM. In addition, in case to use software breakpoint function on the DTU8 debugger, Flash ROM is programmed every time you set software breakpoints.

Since VDDL=2.8V to program Flash ROM, If you use each function with programming the Flash ROM, you should keep the voltage of VDD on the target microcontroller to +2.8V or higher.

For more details, please refer the user's manual of each target microcontroller.

1.5.1 Recommended circuitry of user target board for uEASE connection

Please refer to the attached "uEASE connection manual" for the recommended circuitry of user target microcontroller for uEASE.

2 Getting started

This chapter explains the starting method at the time of actually using uEASE, and the operation method.

2.1 Setting up and Starting up

This clause explains the starting method of uEASE.

In addition, please refer to each user's manual for the following software that operates on host PC.

- DTU8 Debugger User's Manual
- FWuEASE Flash Writer Host program User's Manual

2.1.1 Procedure to Starting up

It starts according to the following procedures.

- (1) Connect a uEASE and a user target board with an attached uEASE interface cable.
- (2) Connect uEASE and host PC with an attached USB cable.
uEASE works with the power supply through USB cable from host PC. Therefore, when a USB cable is connected to uEASE, the POWER indicator on uEASE will turn on a light.
- (3) A power supply is supplied to a user target board
- (4) The software on Host computer is started.

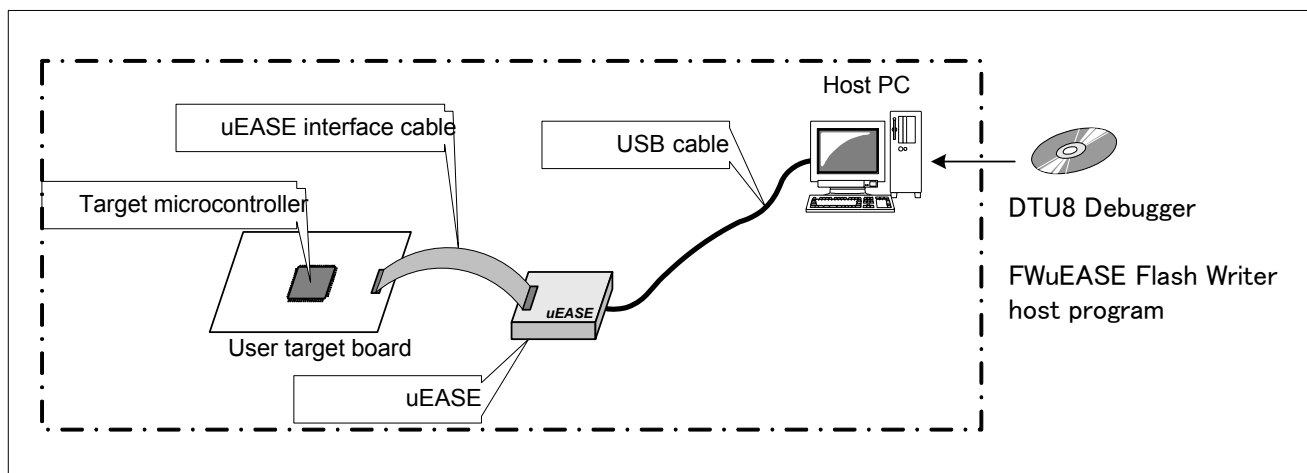

Fig 2-1 uEASE System configuration



Caution

Be sure to protect a starting procedure. If turn is mistaken, the may break down, or it may cause a fire



Caution

Be sure to use the accessories provided. If you using a method other than the designated method, the may break down, or it may cause a fire

2.1.2 Procedure to disconnect

- (1) Close the software on host PC
- (2) A user target system is turned off.
- (3) Remove a USB cable from uEASE.
- (4) Remove the uEASE interface cable between uEASE and a user target system.



Caution

Be sure to protect a starting procedure. If turn is mistaken, the may break down, or it may cause a fire

3 Function

This chapter explains the function of uEASE.

3.1 Function

The functional description of uEASE is shown below.

■ On-chip debug function

The uEASE provides the on-chip debug function by connection to the DTU8 debugger. In this case, you can use the following functions.

- A download, display and change the contents of your application program in the Flash ROM which is embedded in a target microcontroller.
- A display and change of a target microcontroller's status (Registers, ROM/RAM, SFR)
- Emulation (a real-time emulation function, a single step emulation function)
- Break (hardware/software breakpoints, Force break, etc.)

For more details, please refer the attached sheet "uEASE connection manual ML610QXXX".

■ Flash ROM writer function

The uEASE provides the Flash ROM programming function by connection to the FWuEASE Flash Writer host program.

■ Indicator

Correspondence with the state of uEASE and the lighting state of an indicator is shown below.

Table 3-1 The state of the uEASE and indicator

The state of uEASE	Indicator classification	Indicator lighting state
Idle state	POWER	Turn on
	BUSY	Turn off
Emulation running	POWER	Turn on
	BUSY	Turn on
Flash ROM writing	POWER	Turn on
	BUSY	Turn on
Detected illegal input voltage at VTref port	POWER	Turn on
	BUSY	Blink (0.5 second interval)
Failed the recognition of device driver	POWER	Blink (0.5 second interval)
	BUSY	Blink (0.5 second interval)
Command execution error	POWER	Blink (0.5 second interval)
	BUSY	Turn off
uEASE failure	POWER	Turn off
	BUSY	Turn off

Each states of uEASE are explained in below.

Idle state	: it means the state of uEASE is waiting for a command from the software on host PC.
Emulation running	: it means a emulation is under execution. To avoid damaging a target microcontroller, please do not remove each cables at this state.
Flash ROM writing	: it means the state of uEASE is writing contents into the Flash ROM. To avoid damaging a target microcontroller, please do not remove each cables at this state.
Detected illegal input voltage on VTref port	: it means the supplied voltage on VTref port of uEASE is not within the guaranteed range of uEASE. Please confirm connections and their restrictions between uEASE and user target board, and check the voltage level of power supply on a user target board.
Failed the recognition of device driver	: It means the host PC cannot recognize uEASE connected to host PC with the USB cable. Please install a device driver according to the dialog displayed on host PC.
Command execution error	: it means the state of command response from a target microcomputer to uEASE is not normal. Please confirm whether there is any problem in the connection state of a user target system and uEASE, and a command operating procedure.
uEASE failure	: It means the uEASE may be out of order. Continued use risks fire and electrical shock. Please extract immediately the USB cable connected to uEASE, and separate all external power cords. Please contact a distributor, when you cannot discover a problem in the connection state of uEASE and a user target system, and the connection state of uEASE and a USB cable.

4 Notes

4.1 Notes

4.1.1 About the environment

uEASE may be influenced by outside environments, such as host PC, USB cable, uEASE interface cable, and user target system..

Please use uEASE after checking operation in your environment.

4.1.2 About flash programming

When you use uEASE as a flash programmer, please use uEASE after confirming that the voltage of flash programming power supply (VPP), positive power supply (VDD), and internal logic power supply (VDDL) which are applied to the target microcontroller is within the limits of flash memory operation conditions.

Moreover, please confirm that your program carries out normal operation after programming.

Please refer to the user's manual "flash memory operation conditions" of each target microcontroller about voltage.

4.1.3 About cables

Be sure to use the accessories provided.

If you use other accessories, we can not guarantee the function of uEASE.



Caution

Be sure to use the accessories provided. If you using a method other than the designated method, the may break down, or it may cause a fire.

5 Appendix

5.1 Form information

5.1.1 uEASE

Item	Description
Outside dimension	50 (W)×17(H)×90(D)[mm]
weight	0.1kg

5.1.2 uEASE Interface Cable

Item	Description
Cable length	150[mm]
Connector form	2.54mm pitch 14 pins Two-row socket

5.1.3 USB Cable

Item	Description
Cable length	100[cm]
Connector form	host side : USB Type-A uEASE side : USB Type-B mini

5.2 External View of the uEASE interface cable

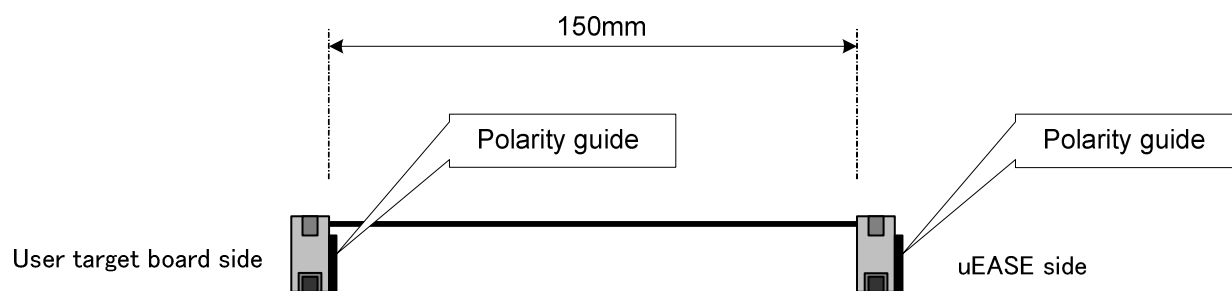

Fig 5-1 uEASE interface cable appearance

