

Built-in antenna IEEE802.11b/g/n (1x1) Wireless LAN Module BP359B

HARDWARE SPECIFICATION

Version 1.0.0

Revision history

Ver.	Contents	Date
1.0.0	First edition	17/4/17

1 ABSTRACT

This document is specification for the wireless LAN module built-in wireless LAN LSI BU1805GU and antenna based on IEEE802.11b/g/n (1×1) made by ROHM.

2 CONTENTS

1	ABSTRACT	3
2	CONTENTS	4
3	ABSOLUTE MAXIMUM RATINGS	5
4	RECOMMENDED OPERATING CONDITIONS.....	6
5	MAIN CHARACTERISTICS	7
6	BLOCK DIAGRAM.....	8
7	ELECTRICAL CHARACTERISTICS.....	9
8	TERMINAL FUNCTIONS.....	10
9	DIMENSIONS	12
10	PRECAUTIONS FOR MOUNTING	13
11	ABOUT THE FIXATION OF THE MODULE	14
12	PRODUCT LABEL SPECIFICATION	15
13	REFERENCE CIRCUIT.....	16
14	PRECAUTIONS WHEN ACCESSING EEPROM	20
15	PRECAUTIONS WHEN ACCESSING FLASH MEMORY OR ROM.....	21
16	OPERATING PRECAUTIONS	23
17	PRECAUTIONS AS A WIRELESS EQUIPMENT.....	24

3 ABSOLUTE MAXIMUM RATINGS

No.	PARAMETER	SYMBOL	LIMITS	UNIT	REMARKS
1	Power supply voltage	VDD	-0.3 ~ +3.6	V	DC
2	Operating temperature range	Topr	-40 ~ +70	°C	No dew condensation
3	Storage temperature range	Tstg	-40 ~ +85	°C	No dew condensation

Note) Absolute maximum ratings are the values that must not be exceeded at any time under any application or any test conditions. Please make design keeping enough margins accordingly.

4 RECOMMENDED OPERATING CONDITIONS

No.	PARAMETER	SYMBOL	SPEC			UNIT	REMARKS
			MIN.	TYP.	MAX.		
1	Power supply voltage	VDD	3.1	3.3	3.5	V	DC
2	Operating temperature range	Ta	-40	25	85	°C	No dew condensation

5 MAIN CHARACTERISTICS

No.	PARAMETER	CHARACTERISTICS
1	Frequency width	2,400MHz ~ 2,483.5 MHz (ch1~ch13)
2	Frequency tolerance	Within ± 25 ppm
3	RF output power (*1)	IEEE802.11b : 15dBm \pm 2dB IEEE802.11g : 13dBm \pm 2dB IEEE802.11n : 12dBm \pm 2dB
4	Supported data rates	IEEE802.11b : 1 ~ 11Mbps IEEE802.11g : 6 ~ 54Mbps IEEE802.11n : 6.5 ~ 72.2Mbps
5	Receiving sensitivity (*1)	IEEE802.11b : -94dBm @1Mbps, -89dBm @11Mbps IEEE802.11g : -92dBm @6Mbps, -73dBm @54Mbps IEEE802.11n : -90dBm @6.5Mbps, -68dBm @72.2Mbps
6	Security function	64bit/128bit WEP, TKIP, AES (*2)
7	Host Interface	USB2.0 (Full-Speed mode) SPI UART (~921600bps)
8	Power supply voltage	Only 3.3V

(*1) RF output power and Receiving sensitivity are the performance values at the electric feeding point of antenna shown in the figure below.

(*2) 64bit/128bit WEP, TKIP, and AES are everything processed with hardware.

6 BLOCK DIAGRAM

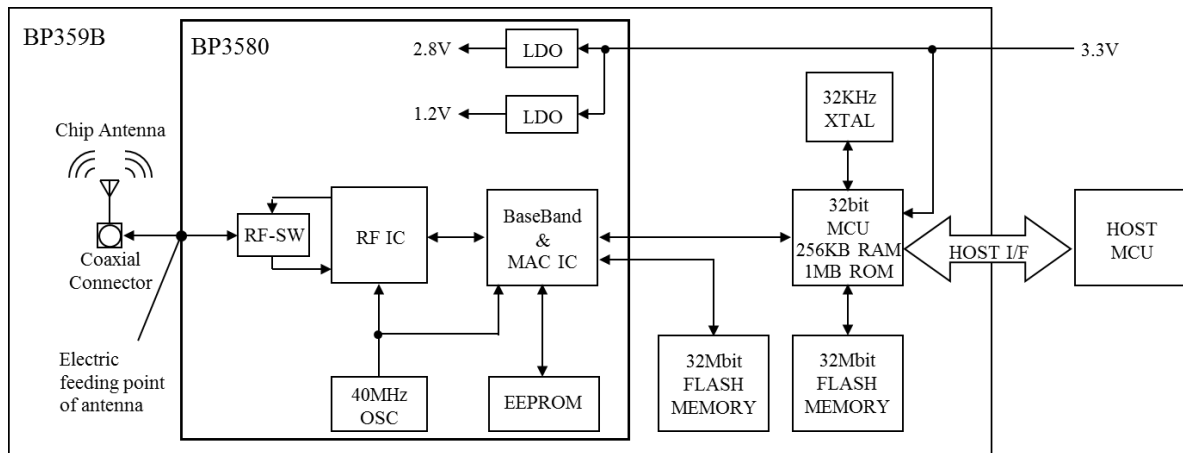

Fig 1. Block diagram

- Between BP3580 and chip antenna, a switch type coaxial connector (MS-156C made by Hirose electric Co., Ltd.) is inserted. Please connect an external antenna to this connector if it is necessary.

When using an external antenna, the built-in antenna (chip antenna) is disabled.

7 ELECTRICAL CHARACTERISTICS

CONDITIONS : Ta=25°C, VCC=3.3V, GND=0.0V

No.	PARAMETER	CONDITION	SPEC			UNIT	REMARKS
			MIN.	TYP.	MAX.		
1	Consumption current	Sending	270	350	430	mA	Continuous
		Receiving	190	230	270	mA	-
		Sleep mode	-	1200	-	μA	Deep Sleep
2	Center frequency	-	2412	-	2472	MHz	-
3	Frequency deviation	-	-25	-	25	ppm	-
4	RF output power	11b : 11Mbps	13	15	17	dBm	(*1)
		11g : 54Mbps	11	13	15	dBm	(*1)
		11n : MCS7	10	12	14	dBm	(*1)
5	Unnecessary emission in the out-of-band	-	-	-	2.5	μW/MHz	-
6	Transmit spectrum mask	DSSS	-	-	-30	dBr	1 st Side-lobe
		11Mbps	-	-	-50	dBr	2 nd Side-lobe
		OFDM 54Mbps	-	-	-20	dBr	±11MHz
			-	-	-28	dBr	±20MHz
			-	-	-40	dBr	±30MHz
7	Receiving sensitivity	11b : 11Mbps	-	-89	-76	dBm	PER<8% (*1)
		11g : 54Mbps	-	-73	-65	dBm	PER<10% (*1)
		11n : MCS7	-	-68	-64	dBm	PER<10% (*1)
8	RX spurious	Fr<1GHz	-	-	4	nW	-
		Fr≥1GHz	-	-	20	nW	-

(*1) At electric feeding point of antenna

8 TERMINAL FUNCTIONS

Back Side

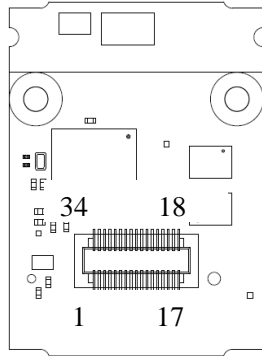

BP359B Connector (Socket) Type
: AXK5F34347YG (Panasonic Electric Works Co., Ltd.)
User-side Connector (header) Type
: AXK6F34347YG(Panasonic Electric Works Co., Ltd.)

Table 1. Module Terminal Functions (1/2)

No.	Terminal	I/O	Function	Remarks
1	UART_RTS	O	UART Flow Control	-
2	UART_CTS	I	UART Flow Control	-
3	GND	-	Ground	-
4	GND	-	Ground	-
5	USB_DM	AI/O	USB Data Minus	-
6	USB_DP	AI/O	USB Data Plus	-
7	SPI_CLK	O/I	SPI Data Clock	Master: O / Slave: I
8	VDD	-	Power Supply 3.3V	-
9	VDD	-	Power Supply 3.3V	-
10	SPI_TXD	O	SPI Transmit Data	-
11	SPI_RXD	I	SPI Receive Data	-
12	SPI_RDY	I/O	SPI Ready	Master: I / Slave: O
13	UART_RXD	I	UART Receive Data	
14	UART_TXD	O	UART Transmit Data	
15	BOOT_SEL1	I	Boot Mode Select	BOOT_SEL [1:0]
16	BOOT_SEL0	I		00:USB, 01:SPI, 10:Reserve, 11:USB
17	SPI_FS	O/I	SPI Device Select	Master: O / Slave: I

Table 1. Module Terminal Functions (2/2)

No.	Terminal	I/O	Function	Remarks
18	GPIO10	I/O	General Purpose Input / Output 10	Factory Default Firmware Boot
19	GPIO11	I/O	General Purpose Input / Output 11	Cable LAN/Wireless LAN Switch
20	GPIO12	I/O	General Purpose Input / Output 12	Combination with SPI_HOST INT
21	GPIO13	O/I	General Purpose Input / Output 13	Combination with SPI_WAKE UP
22	FLASH_SEL	I	Flash Boot Area Select	0: Region1, 1: Region2
23	GPIO00	I	General Purpose Input / Output 0	INITIALIZE
24	GPIO01	I	General Purpose Input / Output 1	WPS
25	M_ANA	AI	Analog Monitor	Reserve
26	GPIO2	O	General Purpose Input / Output 2	Status LED
27	GPIO14	O	General Purpose Input / Output 14	Wake On LAN
28	SRST	I	Soft Reset	0: Reset, 1: Normal
29	PRST	I	Power On Reset	0: Reset, 1: Normal
30	TMS	I	ARM JTAG TDO	For Debug
31	TCK	I	ARM JTAG TCK	For Debug
32	TDI	I	ARM JTAG TDI	For Debug
33	TDO	O	ARM JTAG TDO	For Debug
34	TRSTB	I	ARM JTAG TRSTB	For Debug

The PRST terminal is connected to the 32bit MCU reset terminal inside the module.

The SRST terminal is connected to the 32bit MCU GPIO terminal inside the module.

Reset processing using SRST will only be reset to BP3580.

ARM JTAG terminal is connected to the 32bit MCU ARM debug terminal inside the module.

BOOT_SEL1 and BOOT_SEL0 are pulled down inside the module. To make the logic of these PINs “Low”, please make pin processing “OPEN”.

Unused terminals are pinned “Lo” or “Hi” inside the module, so please “OPEN” it.

9 DIMENSIONS

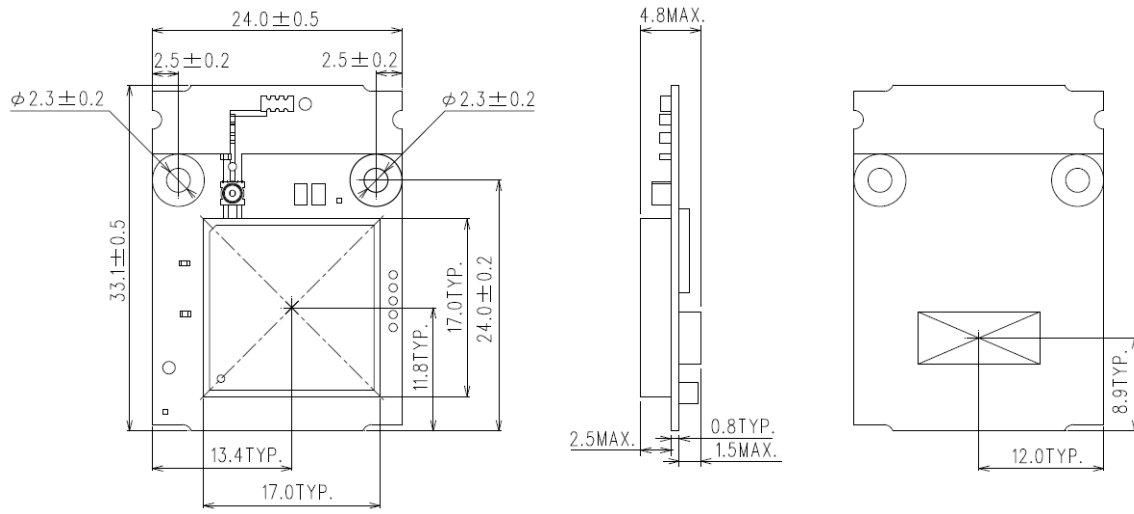

Fig.2 Dimensions (Unit: mm)

10 PRECAUTIONS FOR MOUNTING

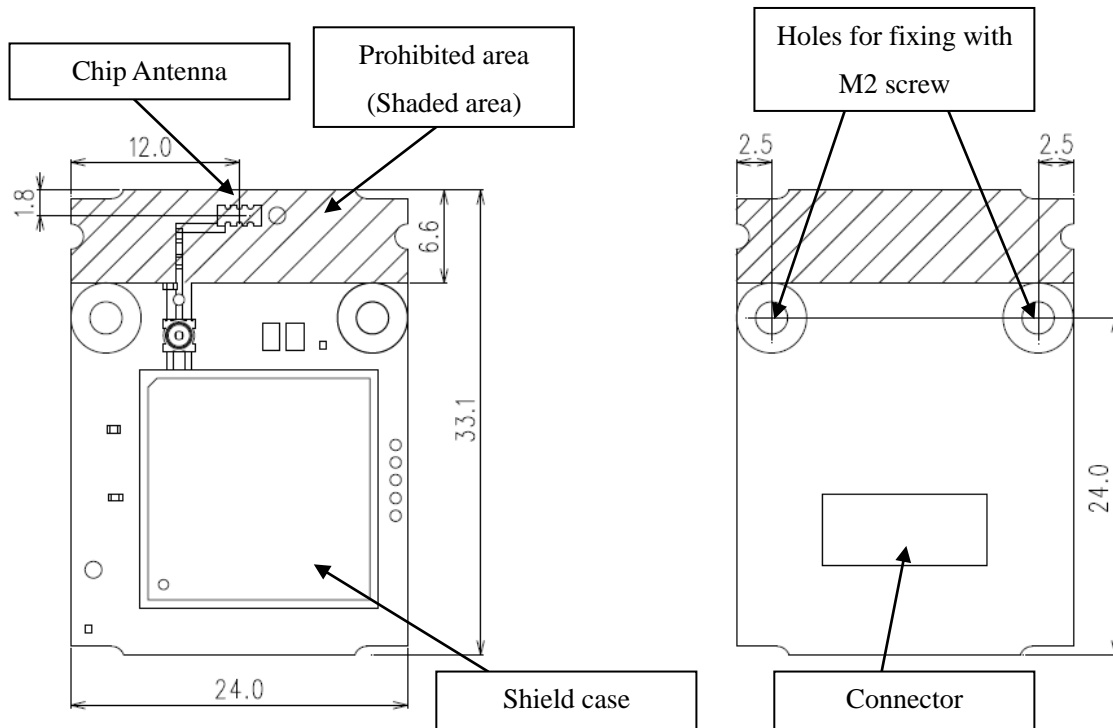

Fig.3 Precautions for Mounting (Unit : mm)

- (1) Don't draw GND solid pattern and wiring on the area overlapping the Prohibited area on the customer's board.
- (2) Please do not place parts in 1cm around the Prohibited area. Also, keep the case away from the case (chassis) away from the Prohibited area by 1cm or more.
- (3) Material of the case (chassis) should be nonmetal.
- (4) Please do not place parts other than specified connector and spacer under BP359B.

11 ABOUT THE FIXATION OF THE MODULE

For fixing BP359B, please use metal M2 screw. Please sandwich the metal spacer with a height of 1.5mm between BP359B and the customer board, and secure with a M2 screw and a nut.

The holes for fixing with M2 screw are the same potential as GND of BP359B. Please connect with GND of BP359B and GND of customer board with metal spacer.

Make sure that the torque when tightening the M2 screw is 1kgf·cm or more and be careful not to over tighten it.

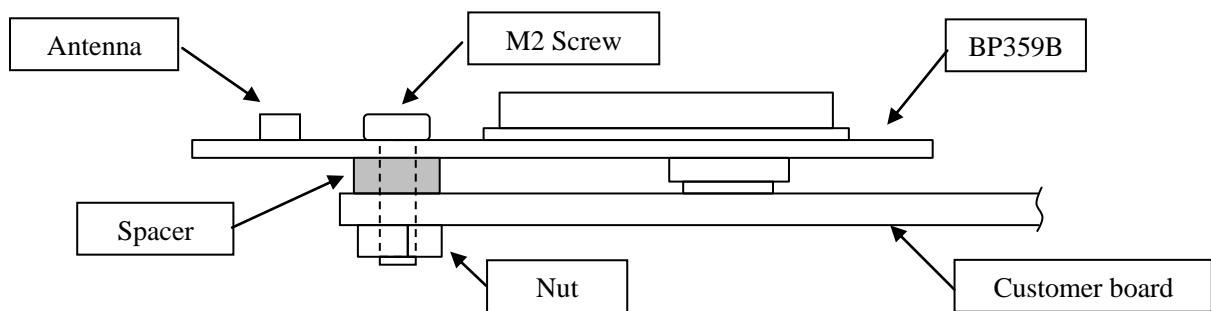

Fig.4 Fixed Module Figure (Side view)

12 PRODUCT LABEL SPECIFICATION

The label shown in the following figure is put on the shield case of BP359B.

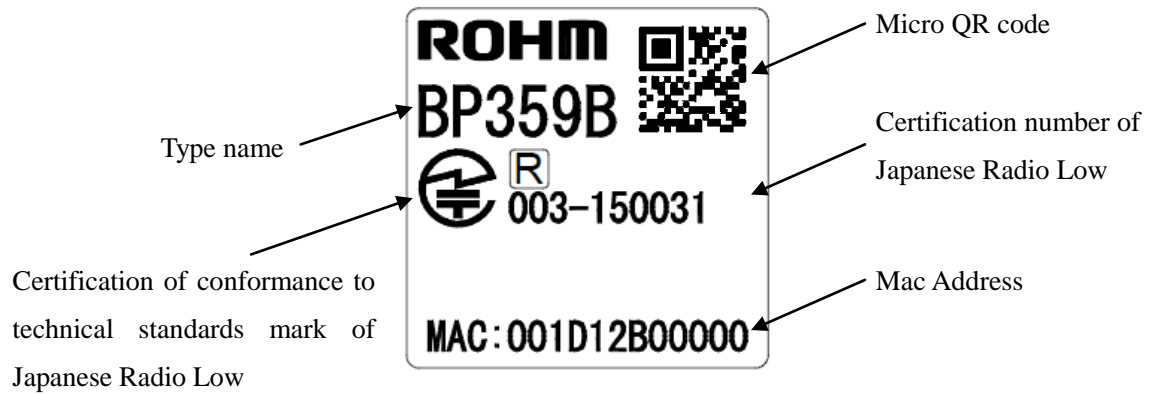

Fig.5 Product Label Spec

*Micro QR code has information on the MAC address.

(Note)The design of product label might change without previous notice.

13 REFERENCE CIRCUIT

13-1 USB HOST INTERFACE

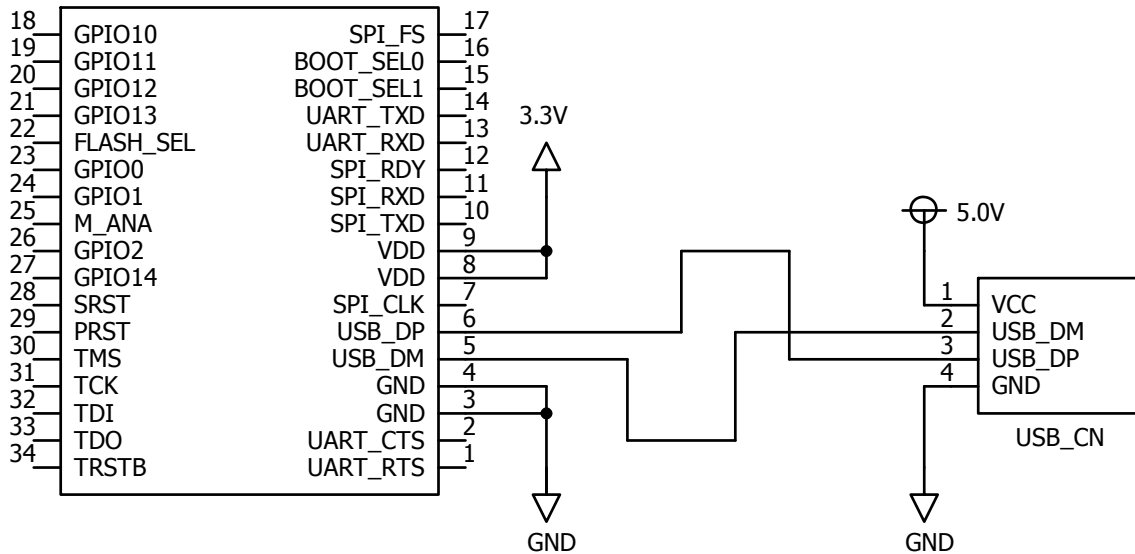

Fig.6 USB Host Interface Reference Circuit

*About USB_DP and USB_DM Lines

- Please shorten the wiring length as much as possible.
- Please take the differential impedance matching to $90\ \Omega \pm 10\%$.
- Please set up to $45\ \Omega \pm 10\%$ for impedance matching of single end.
- Please wire USB_DP and USB_DM lines same lengths as possible.
- Please design so that the wiring length difference is 0.5mm or less.
- Please do not bend USB lines many times and make the bending angle wide angle.
- Please do not make threew hole in wiring if possible.
- Please do not cross the USB lines and another signal lines.
- Please do not cross the USB lines and a power supply line.

*Please reduce the ripple of power supply (VCC=3.3V) as much as possible. (less than 10mVpp)

13-2 SPI HOST INTERFACE

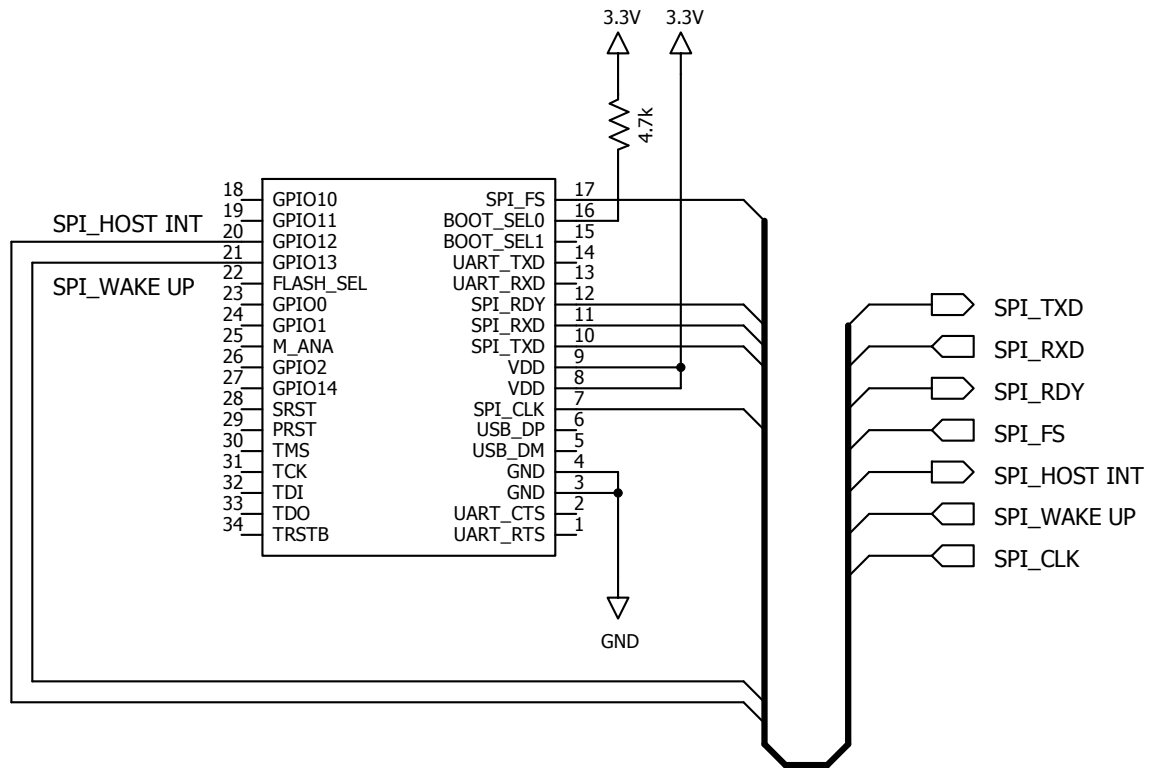

Fig.7 SPI Host Interface Reference Circuit

*Please reduce the ripple of power supply (VCC=3.3V) as much as possible. (less than 10mVpp)

13-3 UART HOST INTERFACE

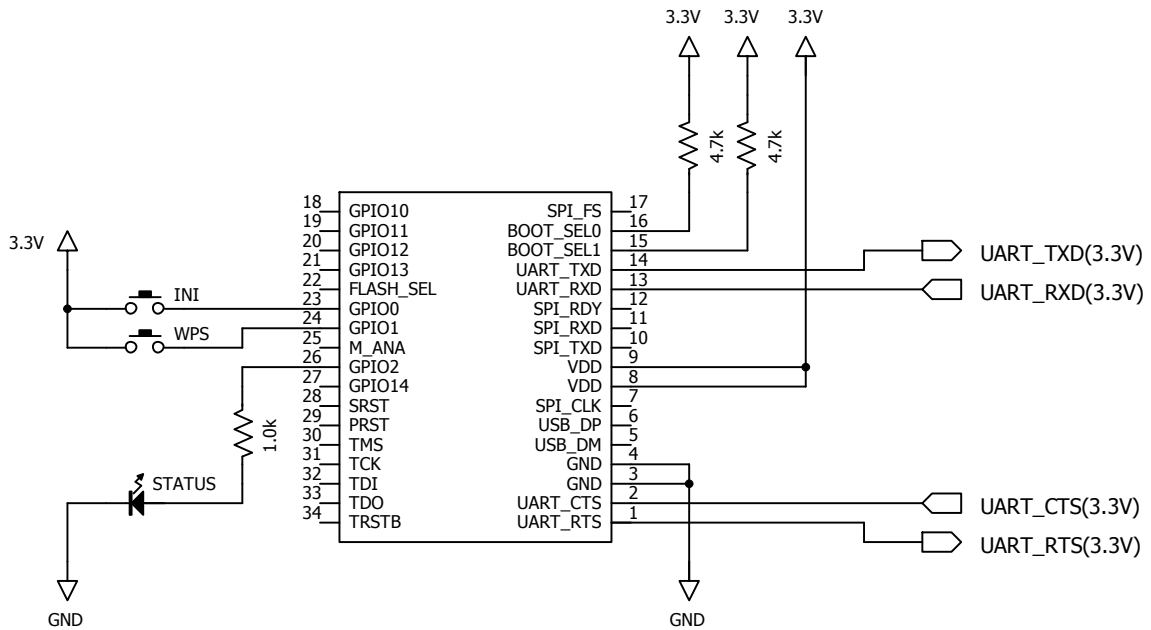

Fig.8 UART Host Interface Reference Circuit

*Please reduce the ripple of power supply (VCC=3.3V) as much as possible. (less than 10mVpp)

13-4 Reset IC

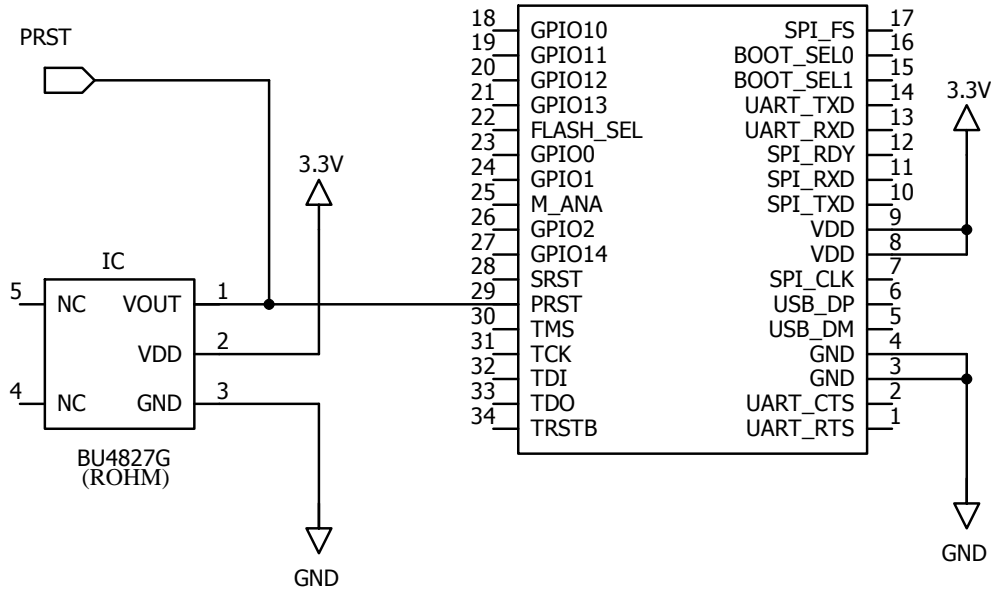

Fig.9 Reset IC Connection Reference Circuit

14 PRECAUTIONS WHEN ACCESSING EEPROM

- Please do not reset (PRST, SRST, COMMAND RESET) when BP359B is accessing internal EEPROM.
- If reset is performed during EEPROM loading, reset may not be performed normally, and it may not be recovered unless power is restored again.

The data will be loaded from EEPROM at the following timing.

①After resetting.

Immediately after power-on or after resetting, the data will be loaded from EEPROM within 100ms.

②When transition to communication mode.

The data will be loaded from EEPROM between transition to communication mode and reception of “device-ready signal”.

③When WID_SERIAL_NUMBER command is issued.

The data will be loaded from EEPROM between issuing WID_SERIAL_NUMBER (Message type “Q”) and receiving WID_STATUS.

15 PRECAUTIONS WHEN ACCESSING FLASH MEMORY OR ROM

- When BP359B is accessing the internal flash memory or the ROM built-in 32bit MCU, please do not reset (PRST, SRST or Command reset) or turn off the power.
- When BP359B is implemented reset or turn off the power while writing (*) to the flash memory or the ROM, the writing may be interrupted and BP359B may not operate correctly.
- In General, flash memory has limitations on the number of write operations. Please design to minimize the number of writes to flash memory.

(*) About write operation to flash memory or ROM

Writing to the flash memory or ROM is performed at the following timing.

1) When updating firmware, root certificate or certification revocation list (CRL).

The flash memory/ROM is being written during the period from issuing WID_HTTP_UPDATE_FW, WID_HTTP_UPDATE_CERT or WID_HTTP_UPDATE_CRL of message type 'W' until WID_STATUS response is returned.

2) On startup immediately after firmware update.

After successfully issuing the WID command (WID_HTTP_UPDATE_FW, WID_HTTP_UPDATE_CERT or WID_HTTP_UPDATE_CRL) of message type 'W', writing to the flash memory/ROM is performed until '+' is received at the next startup.

3) When returning to factory default firmware.

After booting with GPIO10 set to 'Hi', writing to the flash memory/ROM is performed until '+' is received.

4) When WPS is run in standalone mode and credentials are written.

After run WPS in standalone mode, and writing to the flash memory/ROM is performed for 10 seconds after successful connection.

In the case of executing WPS by the WID command, after receiving the WID_STATUS (value=0x01) response after issuing WID_WPS_START (value=0x01/0x02) of the message type 'W', writing to the flash memory/ROM is performed for 10 seconds after receipt of notification of connection completion by WID_STATUS (value=0x01) of message type 'I'.

When starting WPS running GPIO01 with 'Hi', writing to the flash memory/ROM is done for 10 seconds after receiving the connection completion notification with the WID_STATUS (value=0x01) of message type 'I'.

5) When deleting credential information.

After issuing WID_WPS_START (value=0x03) of message type 'W', writing to the flash memory/ROM is performed until the WID_STATUS response is received.

In addition, writing to the flash memory/ROM is performed until '+' is received after booting with GPIO0 set to "Hi".

6) When setting check-ID on firmware or root certificate.

Writing to the flash memory/ROM is performed from issuing WID_CHKID_FW or WID_CHKID_CERT of message type 'W' until receiving WID_STATUS.

7) When entering IPL command input mode.

When '+' is being received, writing to the flash memory/ROM is performed until the space key (0x20) is input 8 times and '#' is received.

8) When performing firmware update in IPL command input mode.

After issuing the 'fwload' command, writing to the flash memory/ROM is performed until firmware is sent via UART and 'OK' is received.

16 OPERATING PRECAUTIONS

- 1) Within one packing, the MAC address of the product may not be sequential number.
- 2) Claims on the presence or absence of fillets of parts mounted on BP359B are not accepted.
- 3) The label claim affixed to BP359B is not accepted except “peeling”, “protrusion” and “extreme character recognition failure” .
- 4) The connector may come off if it receives excessive vibration or impact.
When using it where there is a risk of receiving vibration or shock, please give full evaluation in advance.
- 5) The connector of BP359B is not a specification assuming multiple insertion and removal.
Please set the number of times of insertion / removal with 10times.
- 6) If the external antenna is used for a long time, the elastic force of the spring inside the coaxial connector weakens and the built-in antenna (chip antenna) may become unusable.
Please do not use external antenna together with built-in antenna.

17 PRECAUTIONS AS A WIRELESS EQUIPMENT

BP359B acquired “Certification of Construction Type” (Article 38-24, Clause1 of Radio Law in Japan) of “Particular wireless equipment: Low power data communications system in the 2.4GHz band, which is a Wireless equipment in Article 2-1(19)”

Therefore, only in Japan, it is possible to use as wireless equipment without certification of Japanese radio law.

▪Certification of construction type number : 003-150031

Be sure to keep following notes to use the module safely as wireless equipment.

- 1) The laser marking on the shield case indicates certification number and certification marking of Japanese radio law. Please do not conceal the laser marking.
- 2) Please do not resolve or remodel strictly because there are some cases of receiving penalty based on Japanese radio law.
- 3) Please use the certificated antenna(*).

(*) Please contact us about the certificated antenna separately.

●Precautions for Safety

- 1) Our Products are designed and manufactured for application in ordinary electronic equipment (such as AV equipment, OA equipment, telecommunication equipment, home electronics appliances, amusement equipment, etc.). If you intend to use our Products in devices requiring extremely high reliability (such as medical equipment, transport equipment, traffic equipment, aircraft/spacecraft, nuclear power controllers, fuel controllers, car equipment including car accessories, safety devices, etc.) and whose malfunction or failure may cause loss of human life, bodily injury or serious damage to property (“Special Applications”), please consult with the ROHM sales representative in advance. Unless otherwise agreed in writing by ROHM in advance, ROHM shall not be in any way responsible or liable for any damages, expenses or losses incurred by you or third parties arising from the use of any ROHM’s Products for Specific Applications.

- 2) ROHM designs and manufactures its Products subject to strict quality control system. However, semiconductor products can fail or malfunction at a certain rate. Please be sure to implement, at your own responsibilities, adequate safety measures including but not limited to fail-safe design against the physical injury, damage to any property, which a failure or malfunction of our Products may cause. The following are examples of safety measures.
 - [a] Installation of protection circuits or other protective devices to improve system safety
 - [b] Installation of redundant circuits to reduce the impact of single or multiple circuit failure

- 3) Our Products are designed and manufactured for use under standard conditions and not under any special or extraordinary environments or conditions, as exemplified below. Accordingly, ROHM shall not be in any way responsible or liable for any damages, expenses or losses arising from the use of any ROHM’s Products under any special or extraordinary environments or conditions. If you intend to use our Products under any special or extraordinary environments or conditions (as exemplified below), your independent verification and confirmation of product performance, reliability, etc, prior to use, must be necessary:
 - [a] Use of our Products in any types of liquid, including water, oils, chemicals, and organic solvents
 - [b] Use of our Products outdoors or in places where the Products are exposed to direct sunlight or dust
 - [c] Use of our Products in places where the Products are exposed to sea winds or corrosive gases, including Cl₂, H₂S, NH₃, SO₂, and NO₂
 - [d] Use of our Products in places where the Products are exposed to static electricity or electromagnetic waves

- [e] Use in environment subject to strong vibration and impact.
 - [f] Use of our Products in proximity to heat-producing components, plastic cords, or other flammable items
 - [g] Sealing or coating our Products with resin or other coating materials
 - [h] Use of the Products in places subject to dew condensation
- 4) The products might receive the radio wave interference from electronic devices such as Wireless LAN devices, Bluetooth® devices, digital cordless telephone, microwave oven and so on that radiate electromagnetic wave.
 - 5) The Products are not subject to radiation-proof design.
 - 6) Please verify and confirm characteristics of the final or mounted products in using the Products.
 - 7) Confirm that operation temperature is within the specified range described in the product specification.
 - 8) ROHM shall not be in any way responsible or liable for failure induced under deviant condition from what is defined in this document.
 - 9) This product is a specification to radiate the radio wave. It is necessary to acquire the attestation of decided Radio Law of each region used to use the equipment that radiates the radio wave. Please inquire about the attestation of Radio Law that this product acquires.
 - 10) When product safety related problems arises, please immediately inform to ROHM, and consider technical counter measure.

● Precautions Regarding Reference Circuit

- 1) If change is made to the constant of an external circuit, please allow a sufficient margin considering variations of the characteristics of the Products and external components, including transient characteristics, as well as static characteristics.
- 2) You agree that application notes, reference designs, and associated data and information contained in this document are presented only as guidance for Products use. Therefore, in case you use such information, you are solely responsible for it and you must exercise you own independent verification and judgment in the use of such information contained in this document. ROHM shall not be in any way responsible or liable for damages, expenses or losses

incurred by you or third parties arising from the use of such information.

● **Precaution for Electrostatic**

This Product is electrostatic sensitive product, which may be damaged due to electrostatic discharge. Please take proper caution in your manufacturing process and storage so that voltage exceeding Products maximum rating will not be applied to Products. Please take special care under dry condition (e.g. Grounding of human body / equipment / solder iron, isolation from charged objects, setting of Ionizer, friction prevention and temperature / humidity control).

● **Precaution for Storage / Transportation**

1) Product performance and soldered connections may deteriorate if the Products are stored in the places where:

[a] the Products are exposed to sea winds or corrosive gases, including Cl₂, H₂S, NH₃, SO₂, and NO₂

[b] the temperature or humidity exceeds those recommended by ROHM
Temperature : 5°C-40°C, Humidity : 40%-60%

[c] the Products are exposed to direct sunshine or condensation

[d] the Products are exposed to high Electrostatic

2) The performance of connector fitting is guaranteed for one year from the time of shipment from ROHM only when the above storage conditions are observed.

3) Store / transport cartons in the correct direction, which is indicated on a carton as a symbol. Otherwise bent leads may occur due to excessive stress applied when dropping of a carton.

● **Precaution for product label**

QR code printed on ROHM product package label is for ROHM's internal use only, and please do not use at customer site.

● **Precaution for disposition**

When disposing Products, please dispose them properly using an authorized industry waste company.

● **Precaution Regarding Intellectual Property Rights**

1) All information and data including but not limited to application example contained in this document is for reference only. ROHM does not warrant that foregoing information or data will

not infringe any intellectual property rights or any other rights of any third party regarding such information or data.

- 2) ROHM shall not have any obligations where the claims, actions or demands arising from the combination of the Products with other articles such as components, circuits, systems or external equipment (including software)
- 3) No license, expressly or implied, is granted hereby under any intellectual property rights or other rights of ROHM or any third parties with respect to the Products or the information contained in this document. Provided, however, that ROHM will not assert its intellectual property rights or other rights against you or your customers to the extent necessary to manufacture or sell products containing the Products, subject to the terms and conditions herein.

● Precautions and prohibited items on using the software.

- 1) We prohibit you from reverse engineering, decompiling, disassembling, duplicating or modification of this software (that means software written in this product and software operating on this product provided by ROHM or application software for operating this product provided by ROHM.). If ROHM intellectual property rights are infringed by those acts, we will claim the amount of damage.
- 2) Never modify this product or this software. ROHM assumes no responsibility for any defects that occurred in products that may have been remodeled. Also we will refuse any substitute requests and analysis requests for this defective product. We do not owe any responsibility for legal (such as radio law) liability arising from remodeling the product.
- 3) Please do not transfer this software to a third party, do not license or rent it.
- 4) ROHM does not guarantee all operations using this software. ROHM assumes no responsibility for any direct or indirect damage resulting from the use of the software. Please use the software provided by ROHM after thoroughly evaluating it.

● Other Matters

- 1) This document may not be reprinted or reproduced, in whole or in part, without prior written consent of ROHM.

- 2) The Products may not be disassembled, converted, modified, reproduced or otherwise changed without prior written consent of ROHM.
- 3) In no event shall you use in any way whatsoever the Products and the related technical information contained in the Products or this document for any military purposes, including but not limited to, the development of mass-destruction weapons.
- 4) The proper names of companies or products described in this document are trademarks of registered trademarks of ROHM, its affiliated companies or third parties.

General Precaution

1. Before you use our Products, you are requested to carefully read this document and fully understand its contents. ROHM shall not be in any way responsible or liable for failure, malfunction or accident arising from the use of any ROHM's Products against warning, caution or note contained in this document.
2. All information contained in this document is current as of the issuing date and subject to change without any prior notice. Before purchasing or using ROHM's Products, please confirm the latest information with a ROHM sales representative.
3. The information contained in this document is provided on an "as is" basis and ROHM does not warrant that all information contained in this document is accurate and/or error-free. ROHM shall not be in any way responsible or liable for any damages, expenses or losses incurred by you or third parties resulting from inaccuracy or errors of or concerning such information.