

IPD Series

Automotive 1ch 45 mΩ High-Side Switch with Variable OCD and OCD Mask Function

BV1HD045EFJ-C

General Description

BV1HD045EFJ-C is a 1-ch high-side switch for automotive application. It has built-in over current protection function, thermal shutdown protection function, open load detection function and under voltage lockout function. It is equipped with diagnostic output function for abnormality detection. Since this IC can arbitrarily set the over current protection value and the time until the limit is set by an external component, the optimum over current protection for the load can be easily realized.

Features

- Dual TSD^(Note 1)
- AEC-Q100 Qualified^(Note 2)
- Built-in Variable Over Current Limit Function
- Built-in Variable Over Current Mask Time Setting Function.
- Built-in Open Load Detection Function.
- Built-in Under Voltage Lockout Function (UVLO)
- Built-in Diagnostic Output
- Low On-Resistance $R_{ON} = 45\text{ m}\Omega$ (Typ)
- Monolithic Power Management IC with Control Unit (CMOS) and Power MOSFET on a Single Chip
- Low Voltage Operation ($V_{BB} = 4.3\text{ V}$)

(Note 1) This IC has thermal shutdown (Junction temperature detect) and ΔT_J Protection (Power-MOS steep temperature rising detect).

(Note 2) Grade 1

Applications

- Resistive Load, Inductive Load, Capacitive Load

Typical Application Circuit

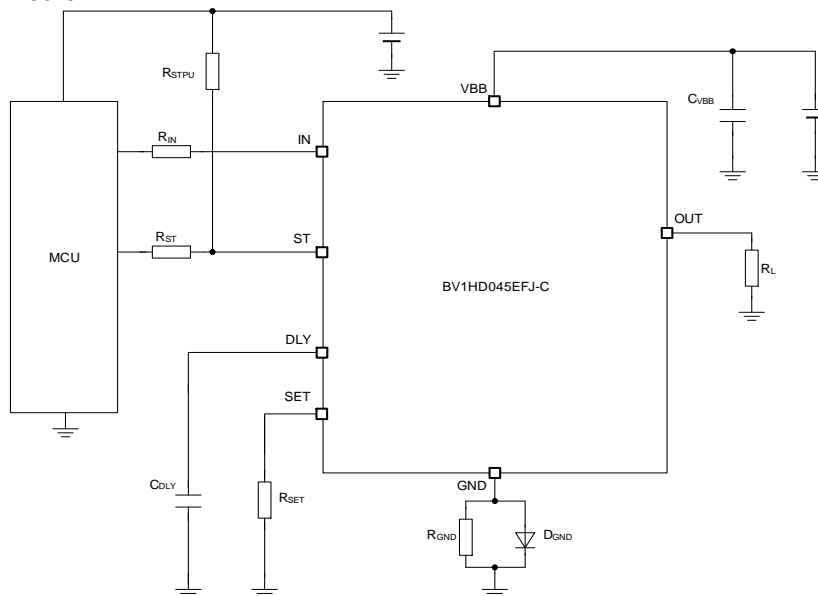

Key Specifications

- Power Supply Voltage Operating Range: 6 V to 28 V
- On Resistance ($T_j=25^\circ\text{C}$): 45 mΩ (Typ)
- Over Current Limit: 21 A (Min)
- Standby Current ($T_j=25^\circ\text{C}$): 0.5 μA (Max)
- Active Clamp Tolerance ($T_{j(\text{START})} = 25^\circ\text{C}$): 50 mJ

Package

HTSOP-J8

W (Typ) x D (Typ) x H (Max)

4.9 mm x 6.0 mm x 1.0 mm



Table of Contents

General Description	1
Features.....	1
Applications	1
Key Specifications	1
Package.....	1
Typical Application Circuit	1
Table of Contents.....	2
Pin Configuration	3
Pin Description.....	3
Block Diagram	3
Definition.....	4
Absolute Maximum Ratings	5
Thermal Resistance	6
Recommended Operating Conditions.....	10
Electrical Characteristics.....	10
Typical Performance Curves.....	12
Measurement Circuit.....	17
Timing Chart (Propagation Delay Time).....	19
Function Description	20
1. Protection Function.....	20
2. Over Current Protection.....	21
3. Open Load Detection.....	24
4. Thermal Shutdown, ΔT_j Protection Detection	25
5. Other Protection	26
Applications Example	27
I/O Equivalence Circuits.....	28
Operational Notes.....	29
Ordering Information.....	31
Marking Diagram	31
Physical Dimension and Packing Information	32
Revision History.....	33

Pin Configuration

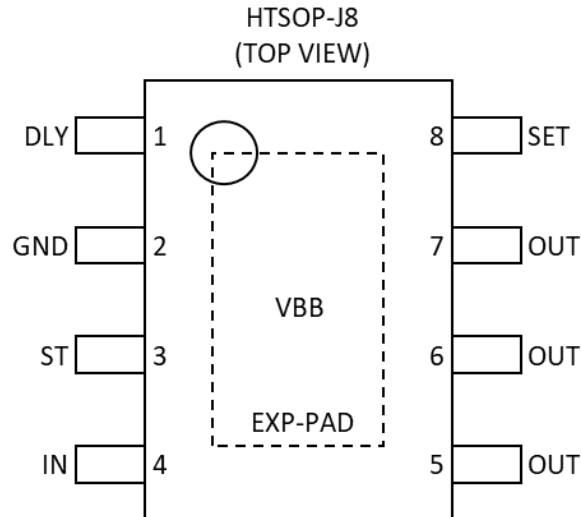

Pin Description

Pin No.	Pin Name	Function
1	DLY	Over current mask time setting pin
2	GND	GND pin
3	ST	Diagnostic output pin
4	IN	Input pin, with internal pull-down resistor
5 to 7	OUT	Output pin
8	SET	Over current limit value setting pin
EXP-PAD	VBB	Power supply pin

Block Diagram

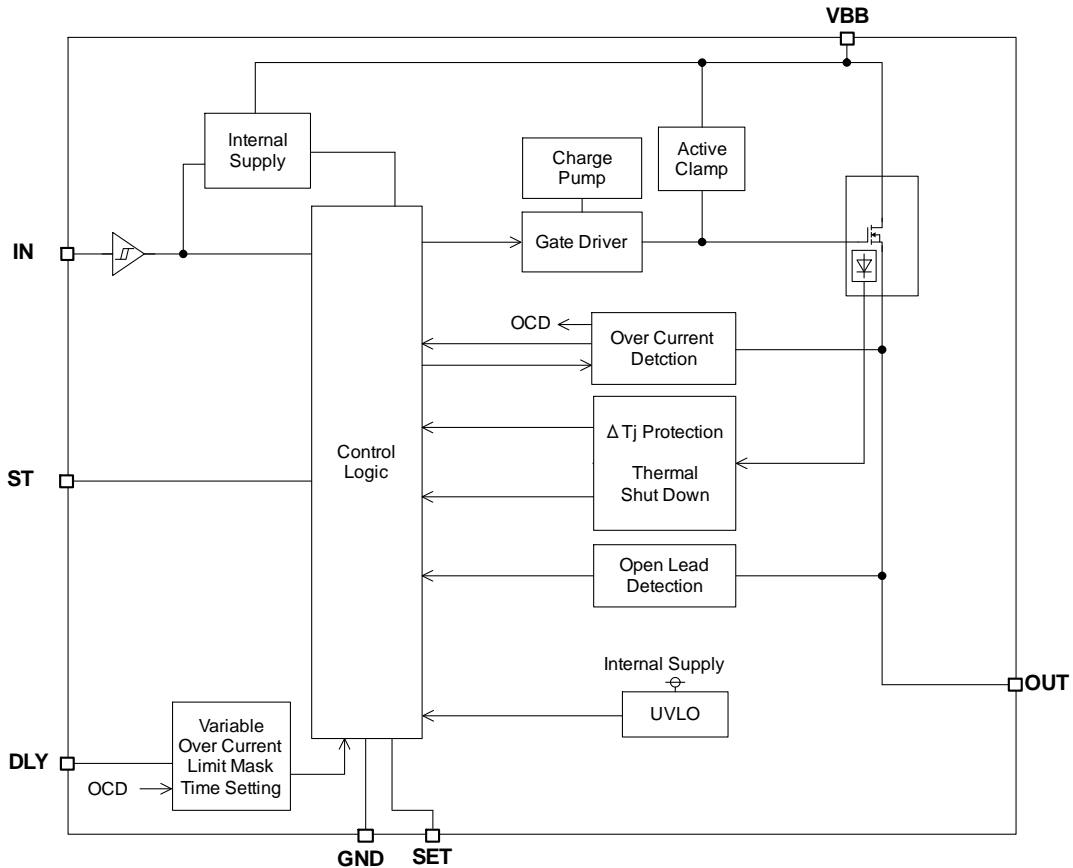

Definition

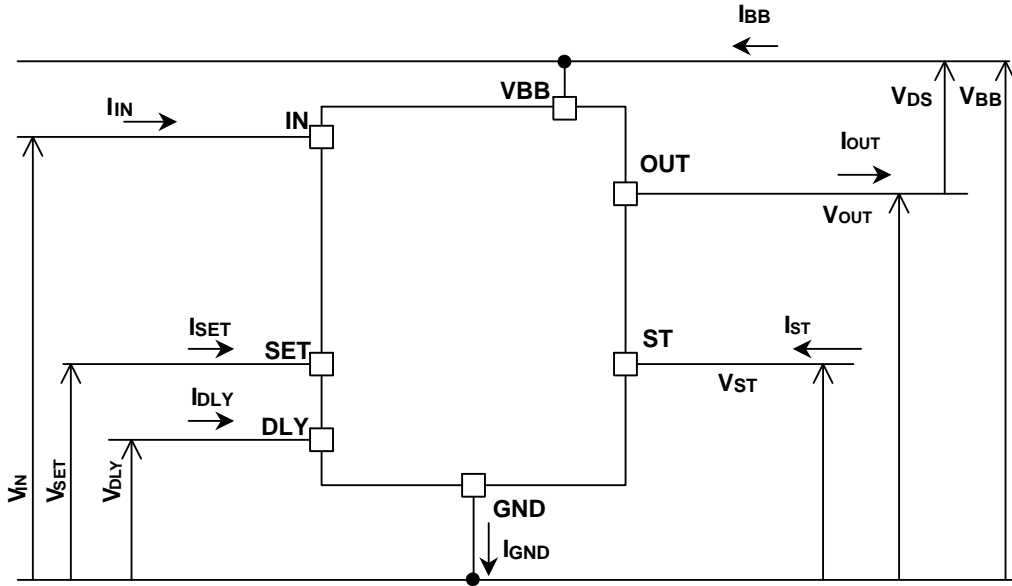

Figure 1. Voltage and Current Definition

Absolute Maximum Ratings (Ta = 25 °C)

Parameter	Symbol	Rating	Unit
VBB - OUT Voltage	V _{DS}	-0.3 to Internal clamp ^(Note 1)	V
Power Supply Voltage	V _{BB}	-0.3 to +40	V
Set Voltage	V _{SET}	-0.3 to V _{BB} +0.3	V
Input Voltage	V _{IN} , V _{DLY}	-0.3 to +7.0	V
Diagnostic Output Voltage	V _{ST}	-0.3 to +7.0	V
Output Current	I _{OUT}	Internal limit ^(Note 2)	A
Diagnostic Output Current	I _{ST}	10	mA
Storage Temperature Range	T _{stg}	-55 to +150	°C
Maximum Junction Temperature	T _{jmax}	150	°C
Active Clamp Energy (Single Pulse) T _{J(START)} = 25 °C, I _{OUT} = 4 A ^{(Note 3)(Note 4)}	E _{AS} (25 °C)	50	mJ
Active Clamp Energy (Single Pulse) T _{J(START)} = 150 °C, I _{OUT} = 4 A ^{(Note 3)(Note 4)}	E _{AS} (150 °C)	25	mJ
Supply Voltage for Short Circuit Protection ^(Note 5)	V _{BBLIM}	24	V

Caution 1: Operating the IC over the absolute maximum ratings may damage the IC. The damage can either be a short circuit between pins or an open circuit between pins and the internal circuitry. Therefore, it is important to consider circuit protection measures, such as adding a fuse, in case the IC is operated over the absolute maximum ratings.

Caution 2: Should by any chance the maximum junction temperature rating be exceeded, the rise in temperature of the chip may result in deterioration of the properties of the chip. In case of exceeding this absolute maximum rating, design a PCB with thermal resistance taken into consideration by increasing board size and copper area so as not to exceed the maximum junction temperature rating.

(Note 1) Internally limited by output clamp voltage.

(Note 2) Internally limited by fixed over current limit.

(Note 3) Maximum active clamp energy using single pulse of I_{OUT(START)} = 4 A and V_{BB} = 14 V.

When IC is turned off in the condition that inductive load is connected, the OUT pin is fell below 0 V. This energy is dissipated by BV1HD045EFJ-C. This energy can be calculated with following equation:

$$E_{AS} = V_{DS} \times \frac{L}{R_L} \times \left[\frac{V_{BB} - V_{DS}}{R_L} \times \ln \left(1 - \frac{R_L \times I_{OUT(START)}}{V_{BB} - V_{DS}} \right) + I_{OUT(START)} \right]$$

Following equation simplifies under the assumption of R_L = 0 Ω.

$$E_{AS} = \frac{1}{2} \times L \times I_{OUT(START)}^2 \times \left(1 - \frac{V_{BB}}{V_{BB} - V_{DS}} \right)$$

(Note 4) Not 100% tested.

(Note 5) Maximum power supply voltage that can detect short circuit protection.

Thermal Resistance^(Note 1)

Parameter	Symbol	Typ	Unit	Condition
HTSOP-J8				
Between Junction and Surroundings Temperature Thermal Resistance	θ_{JA}	130.3	°C / W	1s ^(Note 2)
		36.8	°C / W	2s ^(Note 3)
		25.9	°C / W	2s2p ^(Note 4)
Between Junction and the top center of the outside surface of the component package Thermal Characterization Parameter ^(Note 5)	Ψ_{JT}	20	°C / W	1s ^(Note 2)
		8	°C / W	2s ^(Note 3)
		6	°C / W	2s2p ^(Note 4)

(Note 1) The thermal impedance is based on JESD51-2A (Still-Air) standard. It is used the chip of BV1HD045EFJ-C

(Note 2) JESD51-3 standard FR4 114.3 mm x 76.2 mm x 1.57 mm 1-layer (1s)

(Top copper foil: ROHM recommended Footprint + wiring to measure, 2 oz. copper.)

(Note 3) JESD51-5 standard FR4 114.3 mm x 76.2 mm x 1.60 mm 2-layers (2s)

(Top copper foil: ROHM recommended Footprint + wiring to measure/

Copper foil area on the reverse side of PCB: 74.2 mm x 74.2 mm, copper (top & reverse side) 2 oz.)

(Note 4) JESD51-5/- 7 standard FR4 114.3 mm x 76.2 mm x 1.60 mm 4-layers (2s2p)

(Top copper foil: ROHM recommended Footprint + wiring to measure/

2 inner layers and copper foil area on the reverse side of PCB: 74.2 mm x 74.2 mm, copper (top & reverse side/inner layers) 2 oz./1 oz.)

(Note 5) The thermal characterization parameter to report the difference between junction temperature and the temperature at the top center of the outside surface of the component package.

■ PCB Layout 1 layer (1s)

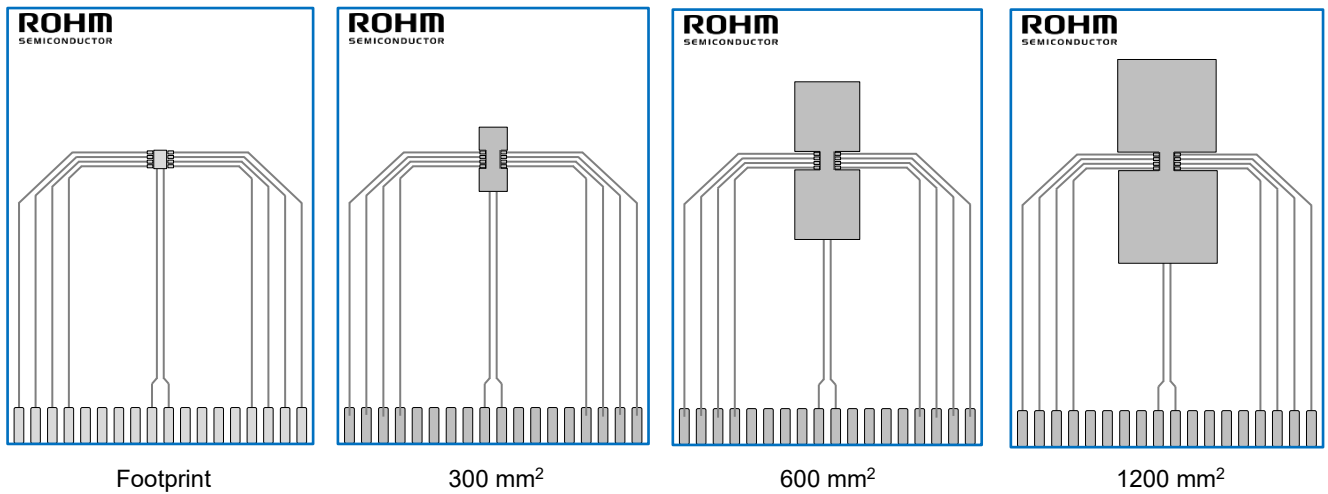

Figure 2. PCB Layout 1 Layer (1s)

Dimension	Value
Board Finish Thickness	1.57 mm ± 10 %
Board Dimension	76.2 mm x 114.3 mm
Board Material	FR4
Copper Thickness (Top Layer)	0.070 mm (Cu:2 oz)
Copper Foil Area Dimension	Footprint / 100 mm² / 600 mm² / 1200 mm²

Thermal Resistance – continued

- PCB Layout 2 layers (2s)

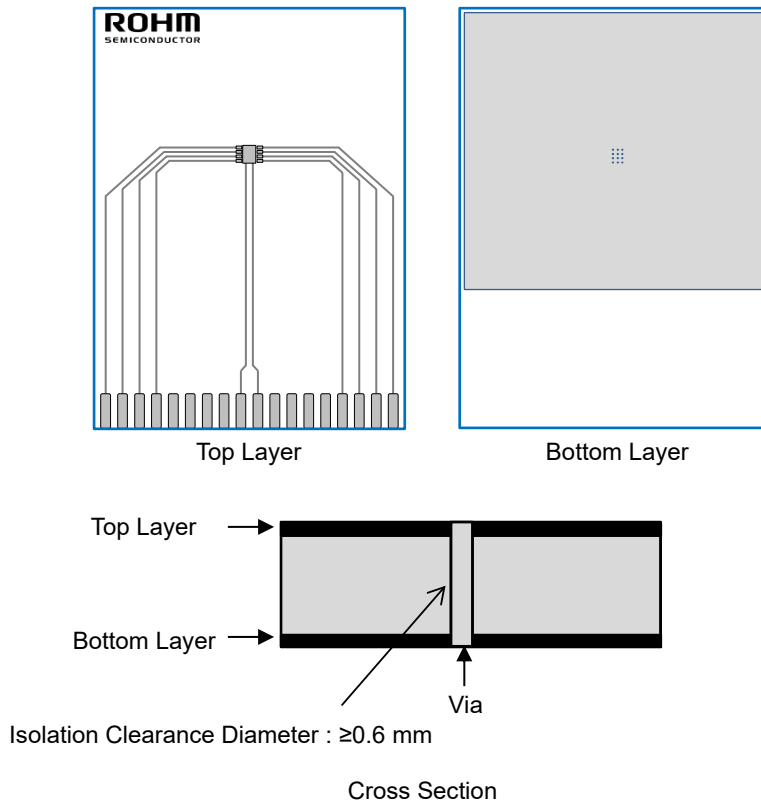

Figure 3. PCB Layout 2 Layers (2s)

Dimension	Value
Board Finish Thickness	1.60 mm \pm 10 %
Board Dimension	76.2 mm x 114.3 mm
Board Material	FR4
Copper Thickness (Top/Bottom Layers)	0.070 mm (Cu +Plating)
Thermal Via Separation/Diameter	1.2 mm / 0.3 mm

Thermal Resistance – continued

- PCB Layout 4 layers (2s2p)

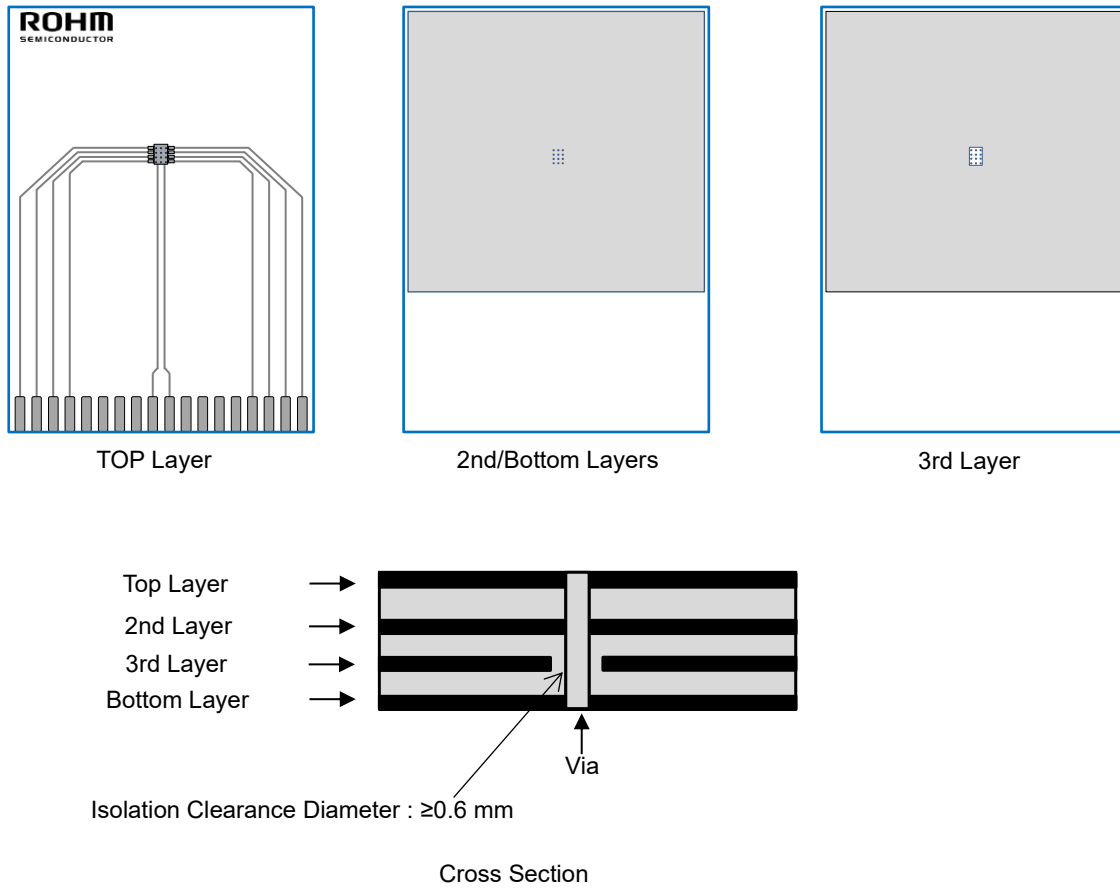

Figure 4. PCB Layout 4 Layers (2s2p)

Dimension	Value
Board Finish Thickness	1.60 mm \pm 10 %
Board Dimension	76.2 mm x 114.3 mm
Board Material	FR4
Copper Thickness (Top/Bottom Layers)	0.070 mm (Cu +Plating)
Copper Thickness (Inner Layers)	0.035 mm
Thermal Via Separation/Diameter	1.2 mm / 0.3 mm

Thermal Resistance – continued

- Transient Thermal Resistance (Single Pulse)

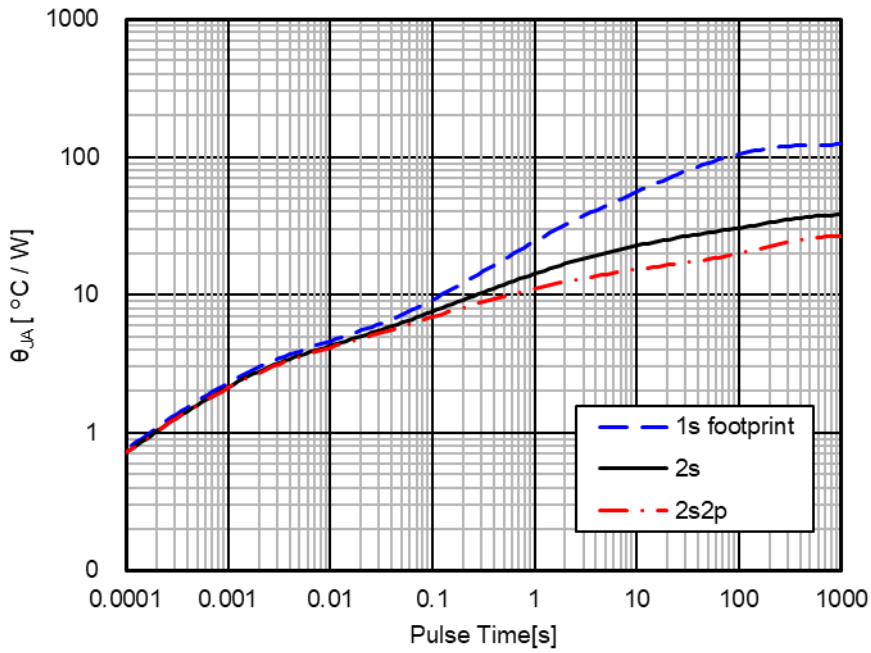

Figure 5. Transient Thermal Resistance

- Thermal Resistance (θ_{JA} vs Copper foil area- 1s)

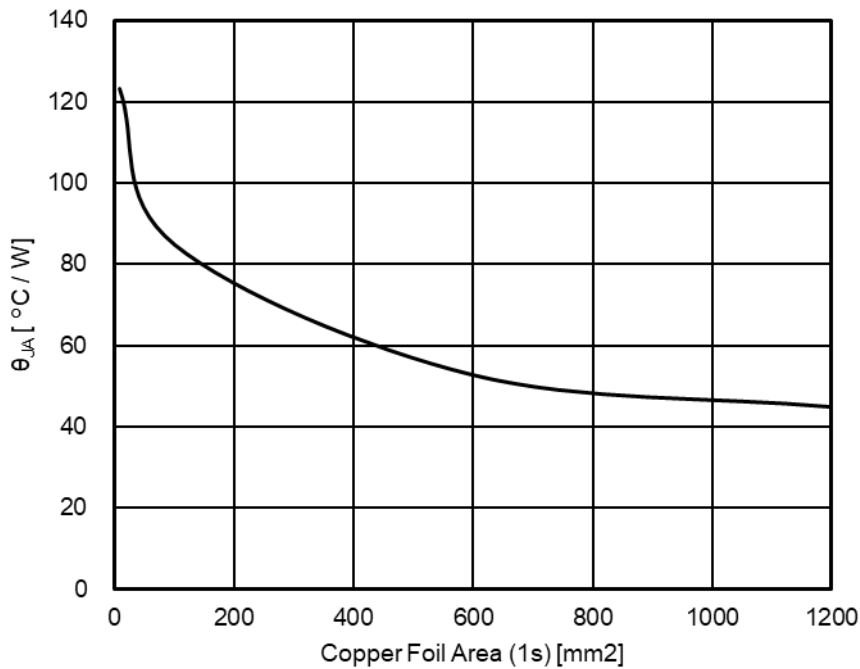

Figure 6. Thermal Resistance

Recommended Operating Conditions

Parameter	Symbol	Min	Typ	Max	Unit
Power Supply Voltage	V_{BB}	6	14	28	V
Operating Temperature	T_{opr}	-40	-	+150	°C
Input Frequency	f_{IN}	-	-	1	kHz

Electrical Characteristics (Unless otherwise specified $6\text{ V} \leq V_{BB} \leq 28\text{ V}$, $-40\text{ °C} \leq T_j \leq +150\text{ °C}$)

Parameter	Symbol	Min	Typ	Max	Unit	Conditions
[Power Supply]						
Standby Current	I_{BBL}	-	-	0.5	μA	$V_{BB} = 14\text{ V}$, $V_{IN} = 0\text{ V}$ $V_{OUT} = 0\text{ V}$, $T_j = 25\text{ °C}$
		-	-	20	μA	$V_{BB} = 14\text{ V}$, $V_{IN} = 0\text{ V}$ $V_{OUT} = 0\text{ V}$, $T_j = 150\text{ °C}$
Operating Current	I_{BBH}	-	3	5	mA	$V_{BB} = 14\text{ V}$, $V_{IN} = 5\text{ V}$ $V_{OUT} = \text{open}$
UVLO Detection Voltage	V_{UVLO}	-	-	4.3	V	
UVLO Hysteresis Voltage	V_{UVHYS}	0.15	0.30	0.45	V	
[Input (V_{IN})]						
High-Level Input Voltage	V_{INH}	2.8	-	-	V	
Low-Level Input Voltage	V_{INL}	-	-	1.5	V	
Input Voltage Hysteresis	V_{INHYS}	-	0.3	-	V	
High-Level Input Current	I_{INH}	-	50	150	μA	$V_{IN} = 5\text{ V}$
Low-Level Input Current	I_{INL}	-10	-	+10	μA	$V_{IN} = 0\text{ V}$
[Output]						
Output On Resistance	R_{ON}	-	45	60	m Ω	$V_{BB} = 8\text{ V}$ to 19 V , $T_j = 25\text{ °C}$ $I_{OUT} = 1\text{ A}$
		-	-	100	m Ω	$V_{BB} = 8\text{ V}$ to 19 V , $T_j = 150\text{ °C}$ $I_{OUT} = 1\text{ A}$
		-	-	75	m Ω	$V_{BB} = 4.5\text{ V}$, $T_j = 25\text{ °C}$ $I_{OUT} = 1\text{ A}$
Output Leak Current	I_{OUTL}	-	-	0.5	μA	$V_{IN} = 0\text{ V}$, $V_{OUT} = 0\text{ V}$, $T_j = 25\text{ °C}$
		-	-	10	μA	$V_{IN} = 0\text{ V}$, $V_{OUT} = 0\text{ V}$, $T_j = 150\text{ °C}$
Output ON Slew Rate	SR_{ON}	-	0.3	1.0	V/ μs	$V_{BB} = 14\text{ V}$, $R_L = 6.5\ \Omega$ $T_j = 25\text{ °C}$
Output OFF Slew Rate	SR_{OFF}	-	0.3	1.0	V/ μs	$V_{BB} = 14\text{ V}$, $R_L = 6.5\ \Omega$ $T_j = 25\text{ °C}$
Output ON Propagation Delay Time	t_{OUTON}	-	70	175	μs	$V_{BB} = 14\text{ V}$, $R_L = 6.5\ \Omega$ $T_j = 25\text{ °C}$
Output OFF Propagation Delay Time	t_{OUTOFF}	-	50	125	μs	$V_{BB} = 14\text{ V}$, $R_L = 6.5\ \Omega$ $T_j = 25\text{ °C}$
Output Clamp Voltage	V_{DSCLP}	41	48	55	V	$V_{IN} = 0\text{ V}$, $I_{OUT} = 10\text{ mA}$

Electrical Characteristics (Unless otherwise specified $6\text{ V} \leq V_{\text{BB}} \leq 28\text{ V}$, $-40\text{ }^{\circ}\text{C} \leq T_{\text{J}} \leq +150\text{ }^{\circ}\text{C}$) - continued

Parameter	Symbol	Min	Typ	Max	Unit	Conditions
[Diagnostic Output]						
Diagnostic Output Low Voltage	V_{STL}	-	-	0.5	V	$V_{\text{IN}} = 5\text{ V}$, $I_{\text{ST}} = 1\text{ mA}$
Diagnostic Output Leak Current	I_{STL}	-	-	10	μA	$V_{\text{IN}} = 0\text{ V}$, $V_{\text{ST}} = 5\text{ V}$
Diagnostic Output ON Propagation Delay Time	t_{STON}	-	100	250	μs	$V_{\text{BB}} = 14\text{ V}$, $R_{\text{L}} = 6.5\ \Omega$ $T_{\text{J}} = 25\text{ }^{\circ}\text{C}$
Diagnostic Output OFF Propagation Delay Time	t_{STOFF}	-	50	125	μs	$V_{\text{BB}} = 14\text{ V}$, $R_{\text{L}} = 6.5\ \Omega$ $T_{\text{J}} = 25\text{ }^{\circ}\text{C}$
[Diagnostic Function]						
Fixed Over Current Limit	I_{LIMH}	21	30	40	A	$V_{\text{IN}} = 5\text{ V}$
Variable Over Current Limit	I_{LIMSET}	2.8	4.1	5.4	A	$V_{\text{IN}} = 5\text{ V}$, $R_{\text{SET}} = 47\text{ k}\Omega$
Open Load Detection Voltage	V_{OLD}	2.0	3.0	4.0	V	$V_{\text{IN}} = 0\text{ V}$
Open Load Detection Sink Current	I_{OLD}	-30	-10	-	μA	$V_{\text{IN}} = 0\text{ V}$, $V_{\text{OUT}} = 5\text{ V}$
Thermal Shutdown ^(Note 1)	T_{TSD}	150	175	200	$^{\circ}\text{C}$	
Thermal Shutdown Hysteresis ^(Note 1)	T_{TSDHYS}	-	15	-	$^{\circ}\text{C}$	
ΔT_{J} Protection Temperature ^(Note 1)	T_{DTJ}	-	120	-	$^{\circ}\text{C}$	

(Note 1) Not 100% tested.

Typical Performance Curves

(Unless otherwise specified $V_{BB} = 14\text{ V}$, $V_{IN} = 5\text{ V}$, $T_j = 25\text{ }^\circ\text{C}$)

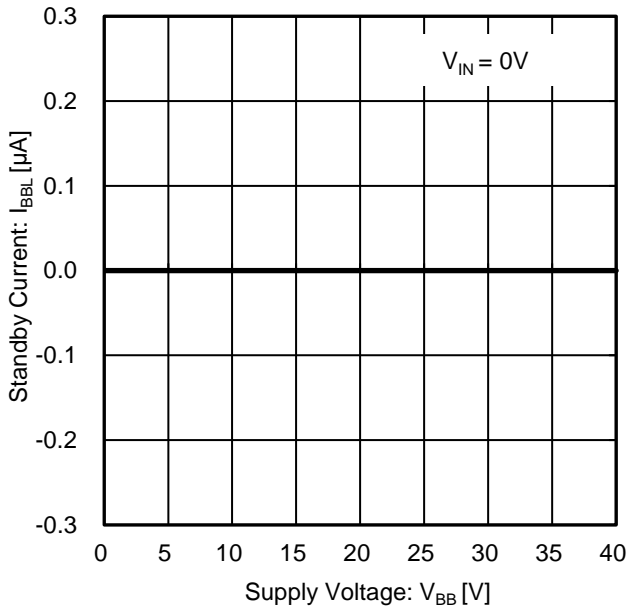

Figure 7. Standby Current vs Supply Voltage

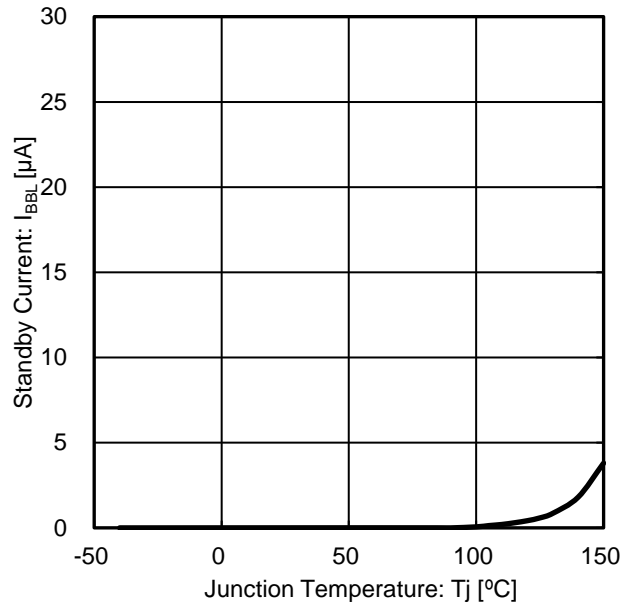

Figure 8. Standby Current vs Junction Temperature

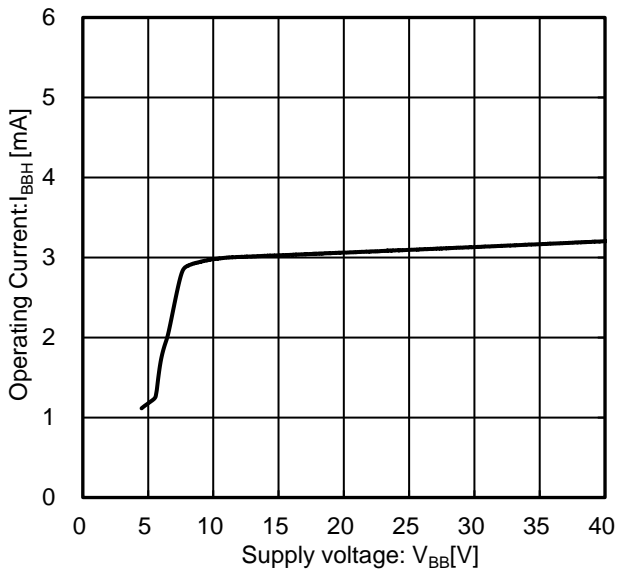

Figure 9. Operating Current vs Supply Voltage

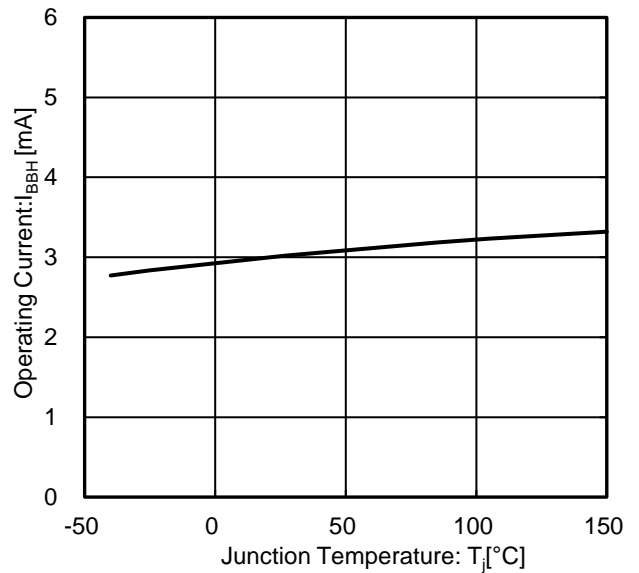

Figure 10. Operating Current vs Junction Temperature

Typical Performance Curves - continued

(Unless otherwise specified $V_{BB} = 14\text{ V}$, $V_{IN} = 5\text{ V}$, $T_j = 25\text{ }^\circ\text{C}$)

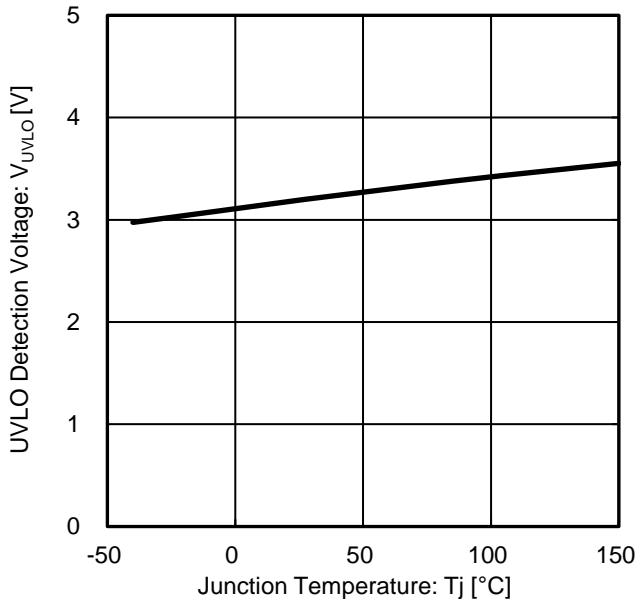

Figure 11. UVLO Detection Voltage vs Junction Temperature

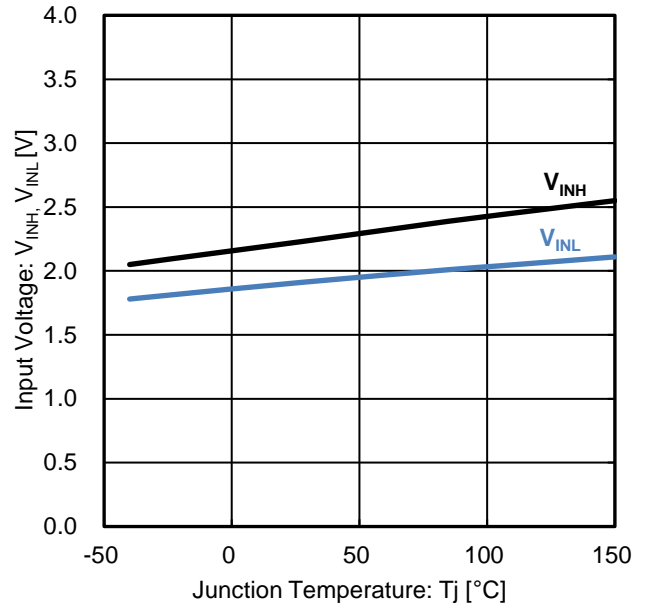

Figure 12. Input Voltage vs Junction Temperature

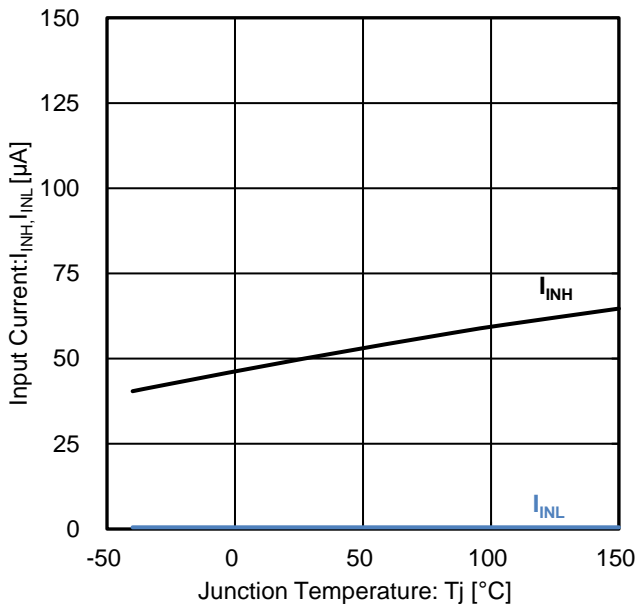

Figure 13. Input Current vs Junction Temperature

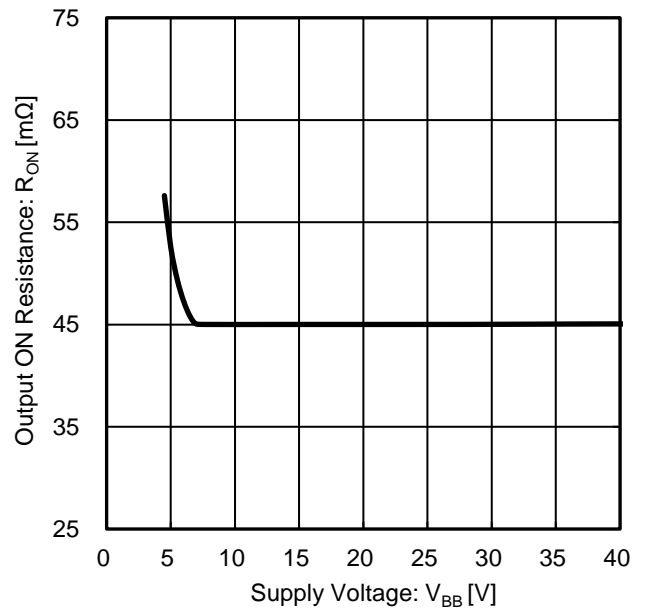

Figure 14. Output ON Resistance vs Supply Voltage

Typical Performance Curves - continued

(Unless otherwise specified $V_{BB} = 14\text{ V}$, $V_{IN} = 5\text{ V}$, $T_j = 25\text{ }^\circ\text{C}$)

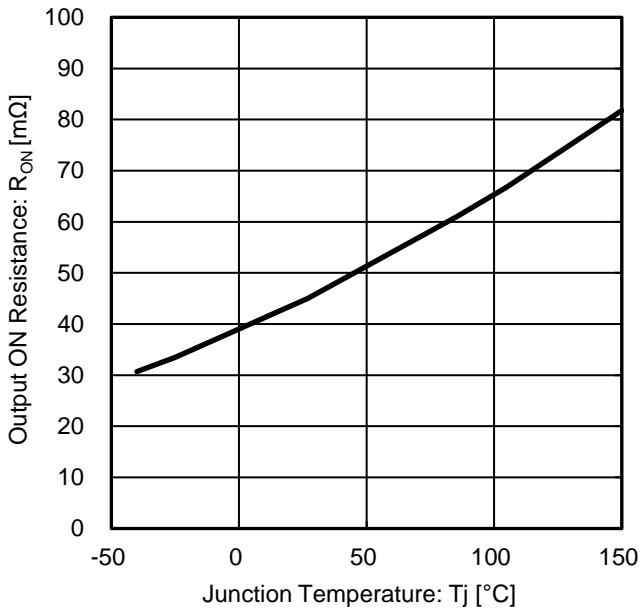

Figure 15. Output ON Resistance vs Junction Temperature

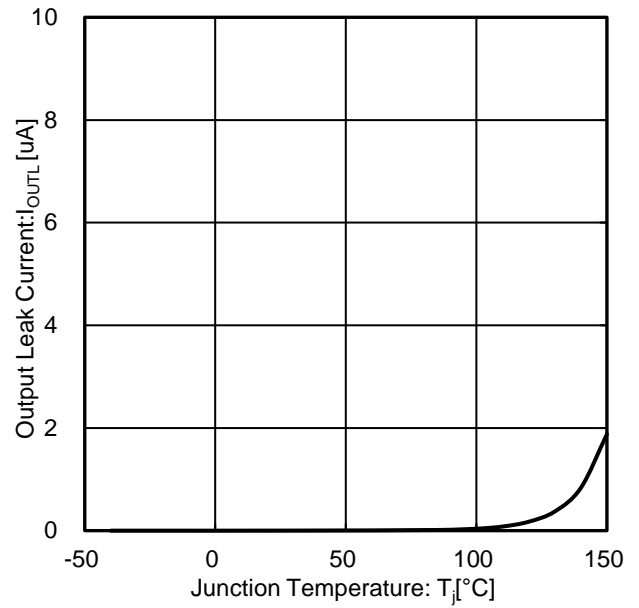

Figure 16. Output leak Current vs Junction Temperature

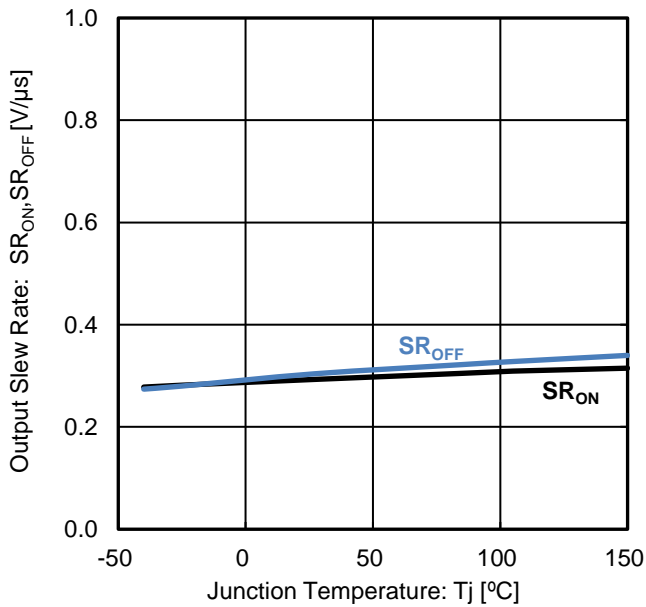

Figure 17. Output Slew Rate vs Junction Temperature

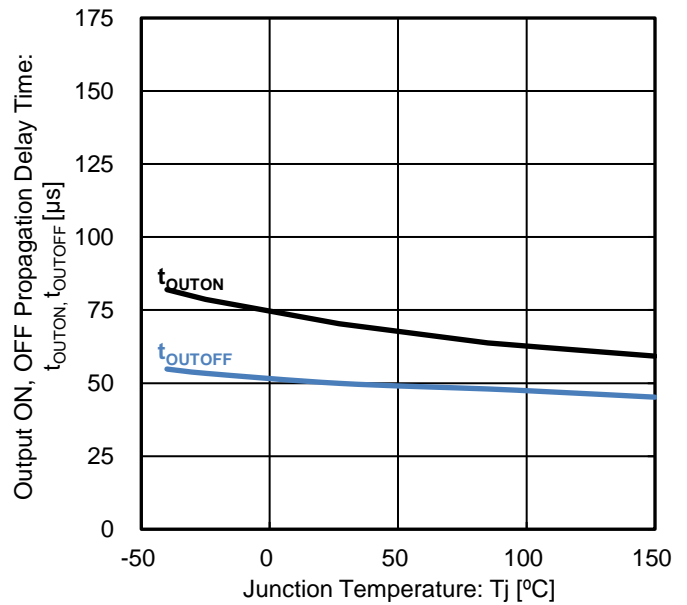

Figure 18. Output ON, OFF Propagation Delay Time vs Junction Temperature

Typical Performance Curves - continued

(Unless otherwise specified $V_{BB} = 14\text{ V}$, $V_{IN} = 5\text{ V}$, $T_j = 25\text{ }^\circ\text{C}$)

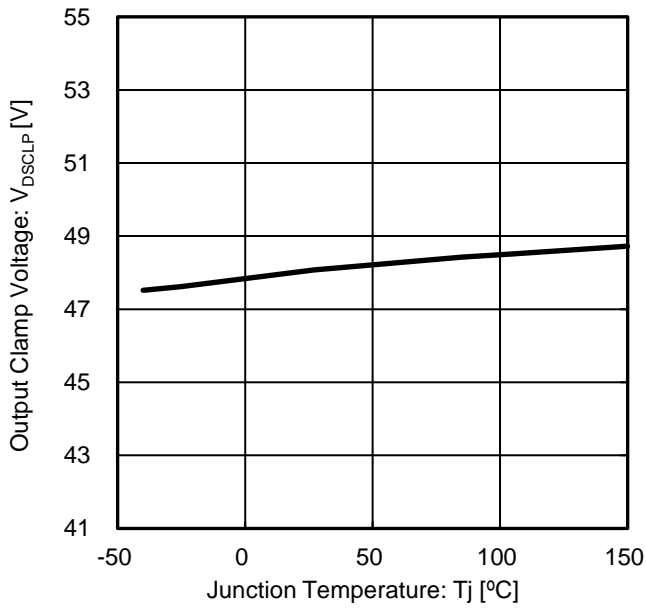

Figure 19. Output Clamp Voltage vs Junction Temperature

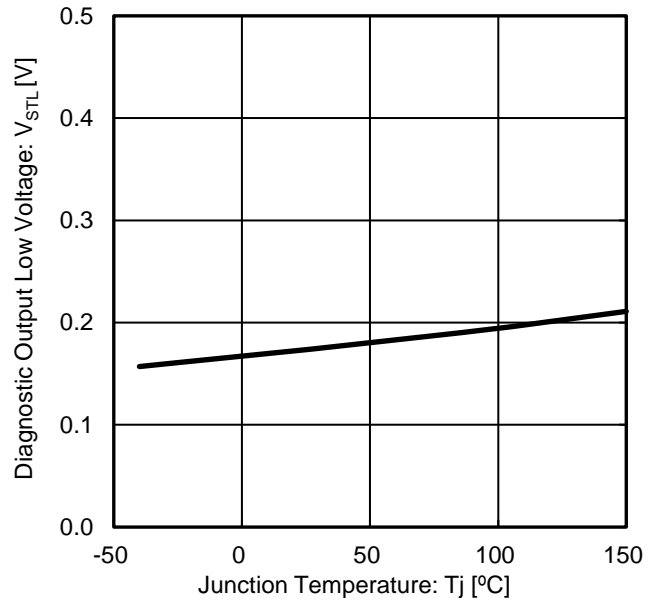

Figure 20. Diagnostic Output Low Voltage vs Junction Temperature

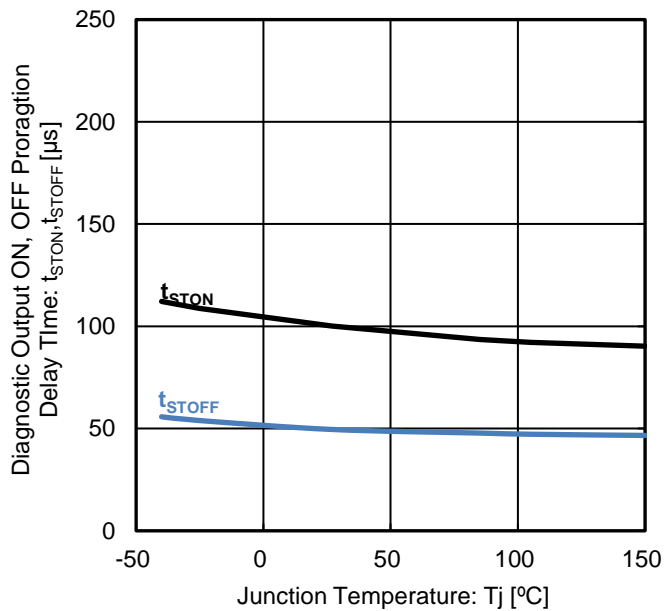

Figure 21. Diagnostic Output ON, OFF Propagation Delay Time vs Junction Temperature

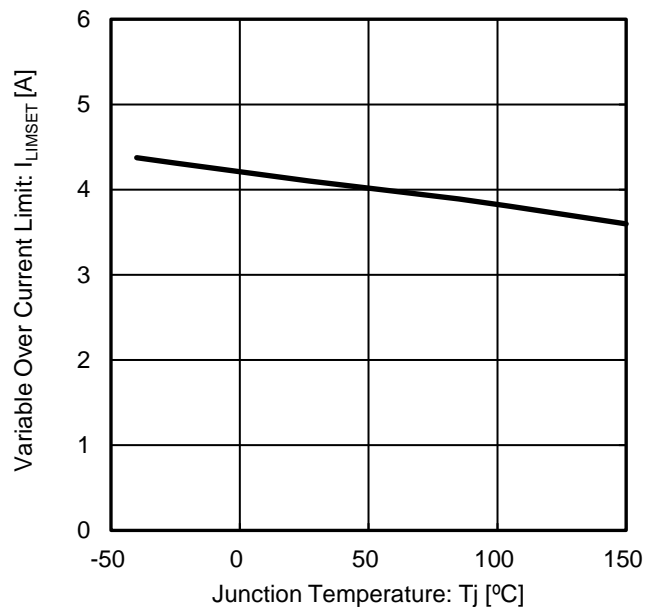

Figure 22. Variable Over Current Limit vs Junction Temperature

Typical Performance Curves - continued
 (Unless otherwise specified $V_{BB} = 14\text{ V}$, $V_{IN} = 5\text{ V}$, $T_j = 25\text{ }^\circ\text{C}$)

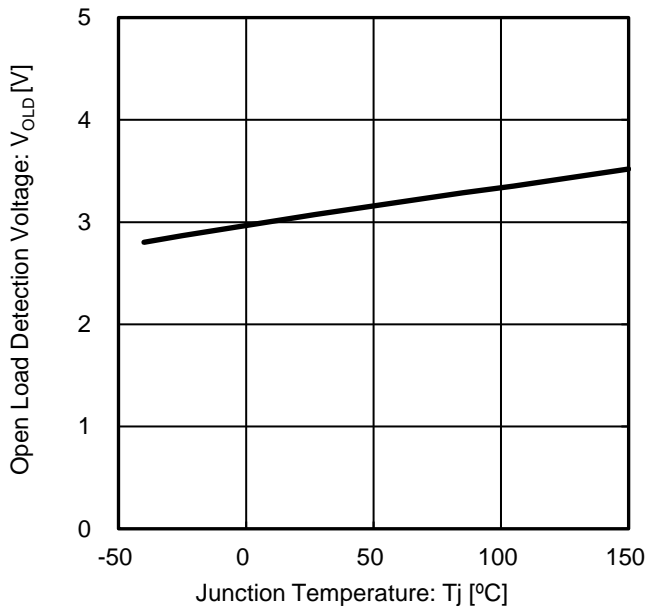

Figure 23. Open Load Detection Voltage vs Junction Temperature

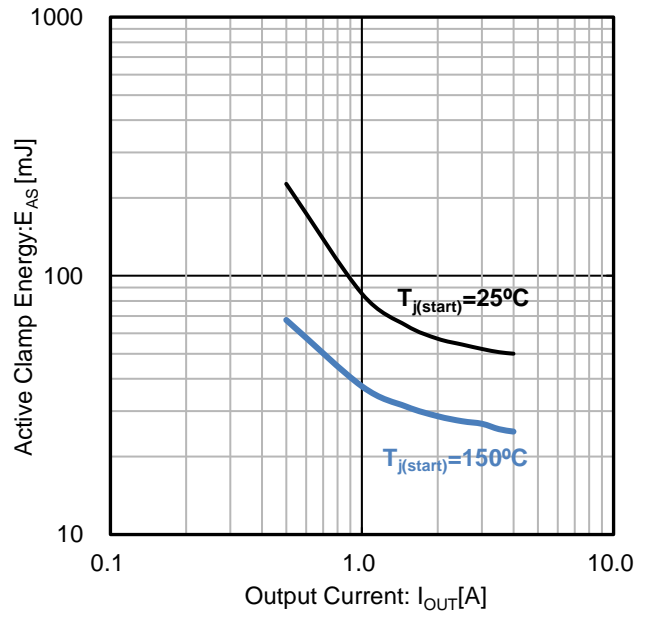

Figure 24. Active Clamp Energy vs Output Current

Measurement Circuit

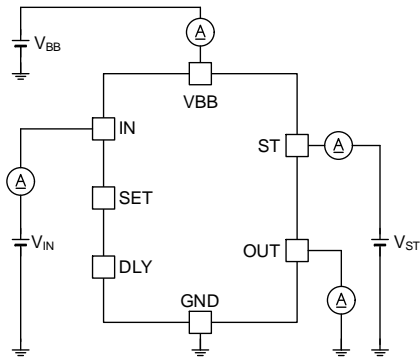

Figure 25. Standby Current
Low-Level Input Current
Output Leak Current
Diagnostic Output Leak Current

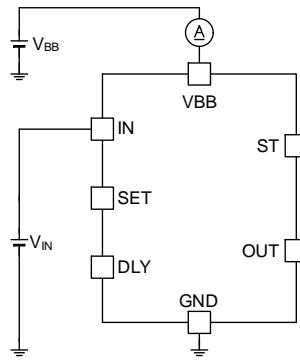

Figure 26. Operating Current

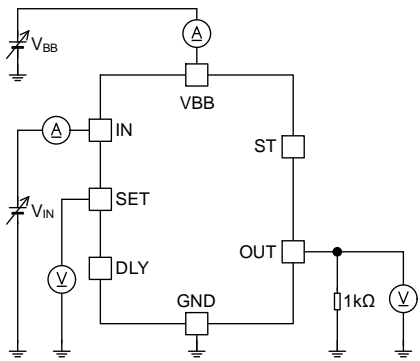

Figure 27. UVLO Detection Voltage
UVLO Hysteresis Voltage
High-Level Input Voltage
Low-Level Input Voltage
Input Voltage Hysteresis
High-Level Input Current
Thermal Shutdown
Thermal Shutdown Hysteresis

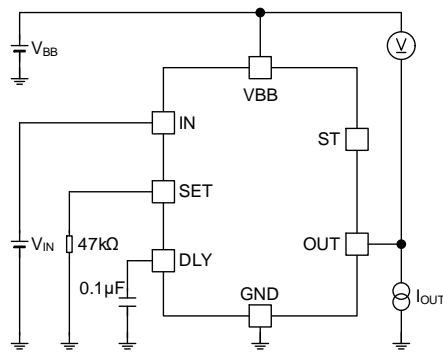

Figure 28. Output ON Resistance
Output Clamp Voltage

Measurement Circuit - continued

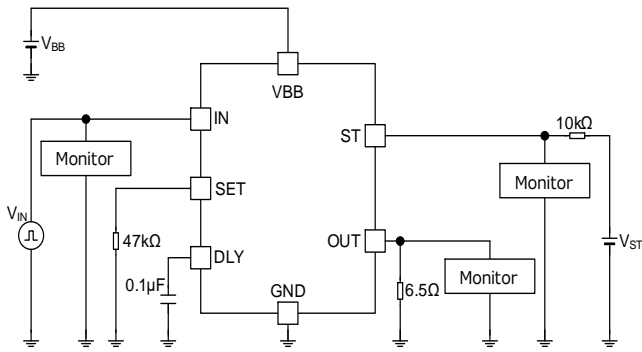

Figure 29. Output ON Slew Rate
Output OFF Slew Rate
Output ON Propagation Delay Time
Output OFF Propagation Delay Time
Diagnostic Output ON Propagation Delay Time
Diagnostic Output OFF Propagation Delay Time

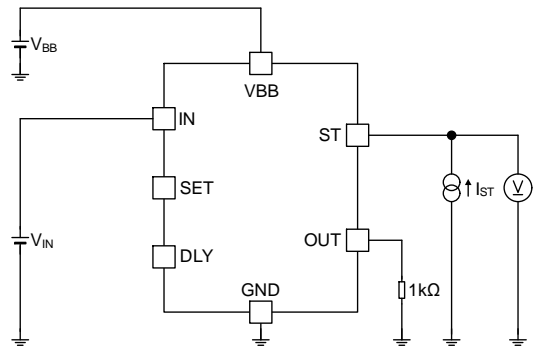

Figure 30. Diagnostic Output Low Voltage

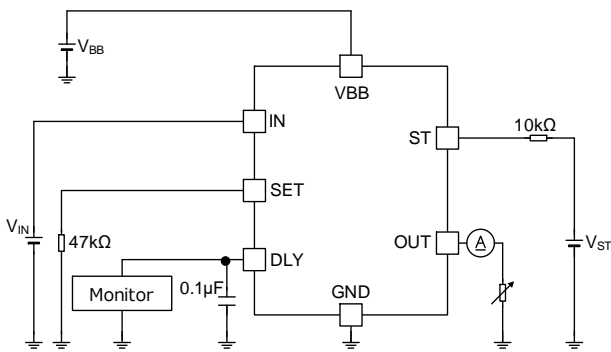

Figure 31. Fixed Over Current Limit
Variable Over Current Limit

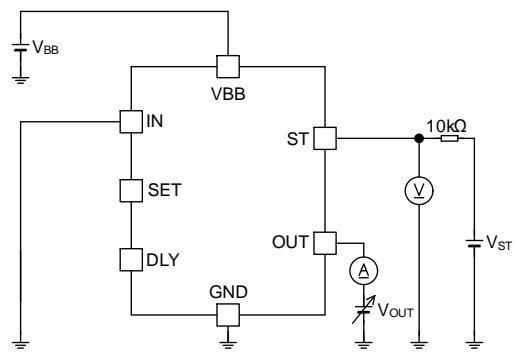

Figure 32. Open Load Detection Voltage
Open Load Detection Sink Current

Timing Chart (Propagation Delay Time)

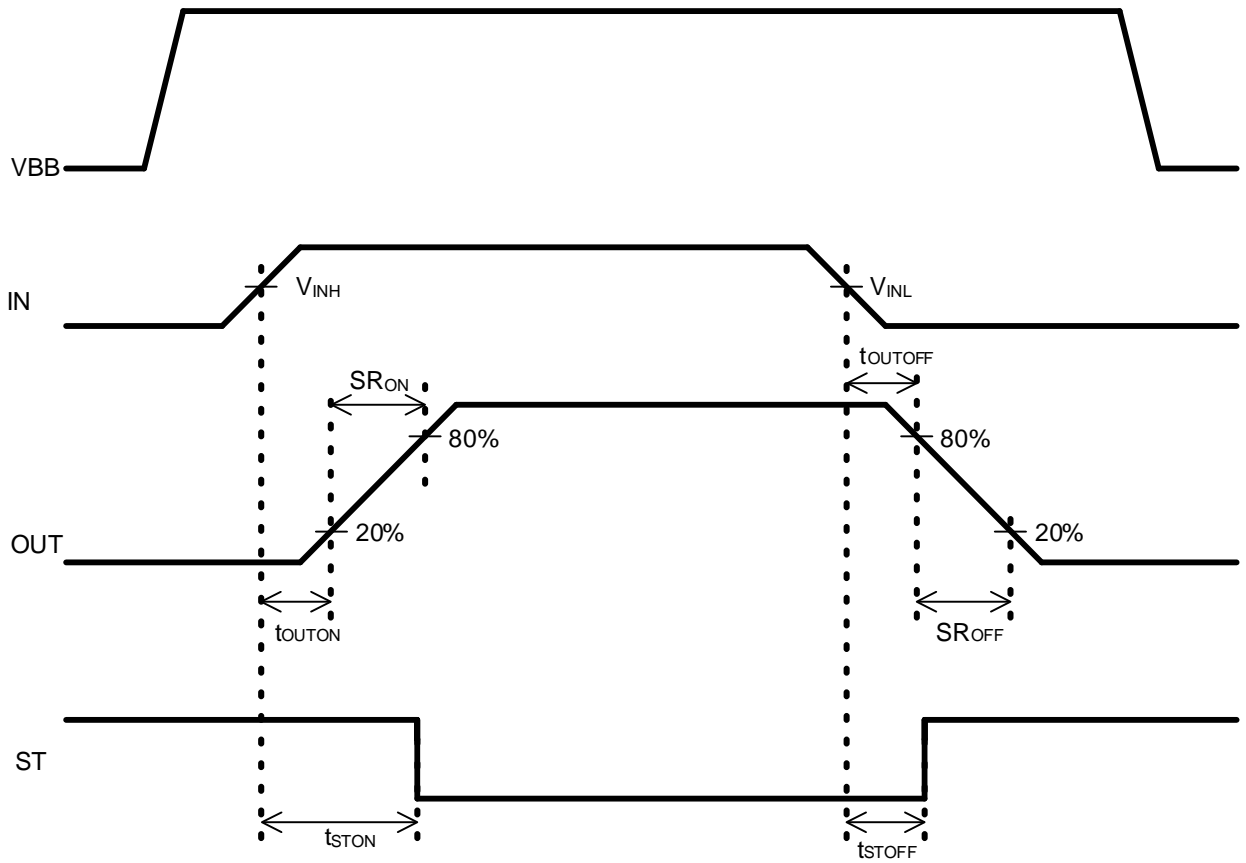

Figure 33. Timing Chart

Function Description

1. Protection Function

Table 1. Detection and Release Conditions of Each Protection Function and Diagnostic Output

Mode		Conditions	IN	ST
Normal Condition	Standby	-	Low	High
	Operating	-	High	Low
Open Load Detect (OLD)		Detect $V_{OUT} \geq 3.0 \text{ V (Typ)}$	Low	Low
		Release $V_{OUT} \leq 2.6 \text{ V (Typ)}$	Low	High
Low Voltage Output OFF (UVLO)		Detect $V_{BB} \leq 4.3 \text{ V (Max)}$	High	High
		Release $V_{BB} \geq 4.7 \text{ V (Max)}$	High	Low
Thermal Shutdown (TSD) ^(Note 1)		Detect $T_j \geq 175 \text{ }^\circ\text{C (Typ)}$	High	High
		Release $T_j \leq 160 \text{ }^\circ\text{C (Typ)}$	High	Low
ΔT_j Protection ^(Note 2)		Detect $\Delta T_j \geq 120 \text{ }^\circ\text{C (Typ)}$	High	High
		Release $\Delta T_j \leq 30 \text{ }^\circ\text{C (Typ)}$	High	Low
Over Current Protection (OCP)		Detect $I_{OUT} \geq I_{LIMSET}$	High	High
		Release $I_{OUT} < I_{LIMSET}$	High	Low

(Note 1) Thermal shutdown is automatically restored to normal operation.

(Note 2) Protect function by detecting PowerMOS sharp increase of temperature difference with control circuit.

Function Description – continued

2. Over Current Protection

2.1 Over Current Limiting Operation

This IC has two over current limiting functions, fixed over current limit (I_{LIMH}) for protecting the IC and variable over current limit (I_{LIMSET}) for protecting the load. The variable over current limit (I_{LIMSET}) can be set by connecting an external resistor to the SET pin. It is also possible to set the variable over current mask time (t_{DLY}) by connecting an external capacitor to the DLY pin.

Timing chart for switching from fixed over current setting (I_{LIMH}) to variable over current limit (I_{LIMSET}) are shown at Figure 34.

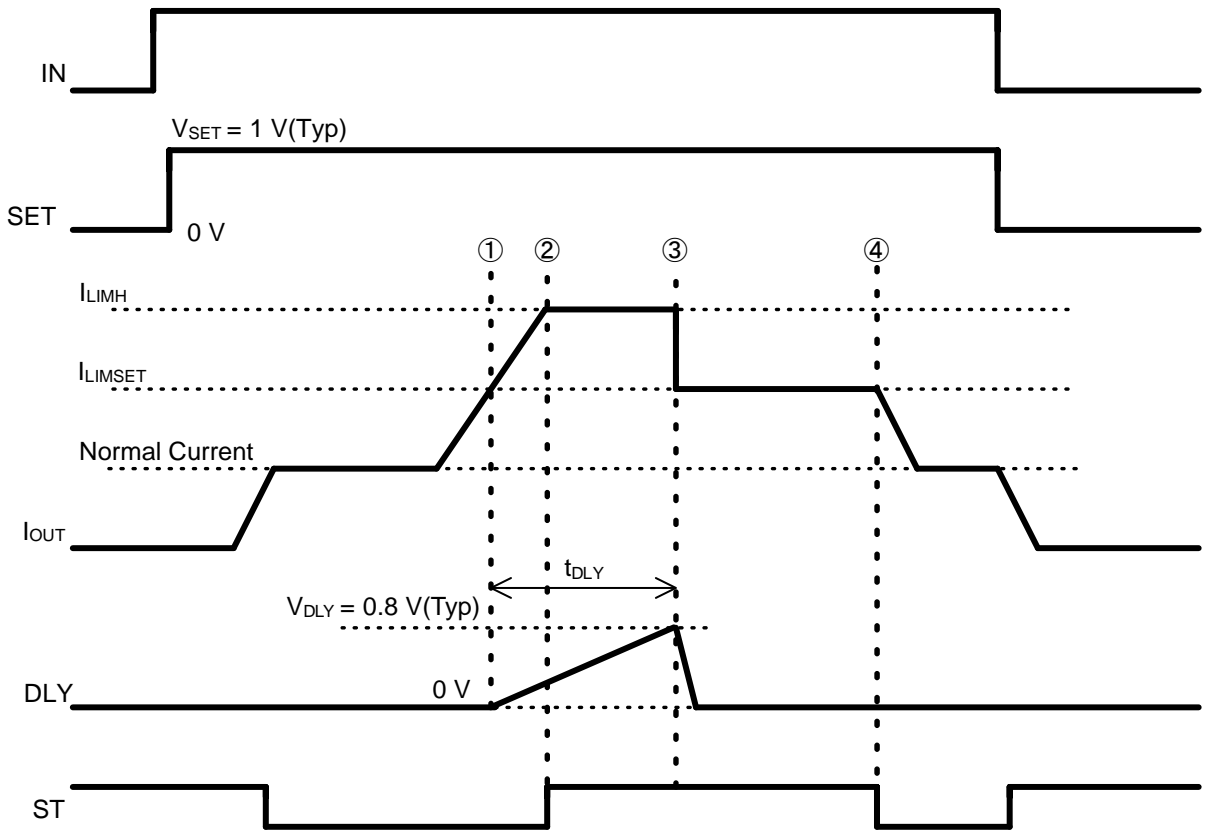

Figure 34. Over Current Detection Timing Chart

- ① When the load current (I_{OUT}) rises and exceeds variable over current limit (I_{LIMSET}), external capacitor C_{DLY} is charged by $5\ \mu\text{A}$ (Typ).
- ② When the load current (I_{OUT}) more rises and exceeds fixed over current limit (I_{LIMH}), I_{OUT} is limited to fixed over current limit value (I_{LIMH}) and $ST = \text{High}$ indicating an abnormal condition.
- ③ When the DLY pin voltage V_{DLY} reaches 0.8 V (Typ) (after t_{DLY}), C_{DLY} is discharged. I_{OUT} is limited to variable over current limit value (I_{LIMSET}) and $ST = \text{High}$ indicating an abnormal condition.
- ④ When output current I_{OUT} becomes less than the variable over current limit value (I_{LIMSET}), the diagnostic output pin (ST) is turned to low.

Function Description – continued

2.2 Setting of Variable Overcurrent Limit Value

There are two values in the over current limit of this IC; fixed over current limit value (I_{LIMH}) and the variable over current limit value (I_{LIMSET}) that can be set by external resistance R_{SET} . The variable over current limit value (I_{LIMSET}) set for the value of R_{SET} is as follows. R_{SET} should be set within the range of 7.5 k Ω to 330 k Ω .

Table 2. Variable Over Current Limit for R_{SET}

R_{SET} [k Ω]	Variable Over Current Limit (I_{LIMSET}) [A]		
	Min	Typ	Max
7.5	7.78	11.39	15.00
10	6.95	10.17	13.39
20	4.82	7.06	9.30
33	3.50	5.13	6.76
47	2.80	4.10	5.40
75	1.98	2.90	3.81
100	1.61	2.36	3.10
150	1.19	1.74	2.29
220	0.78	1.30	1.82
330	0.51	1.01	1.52

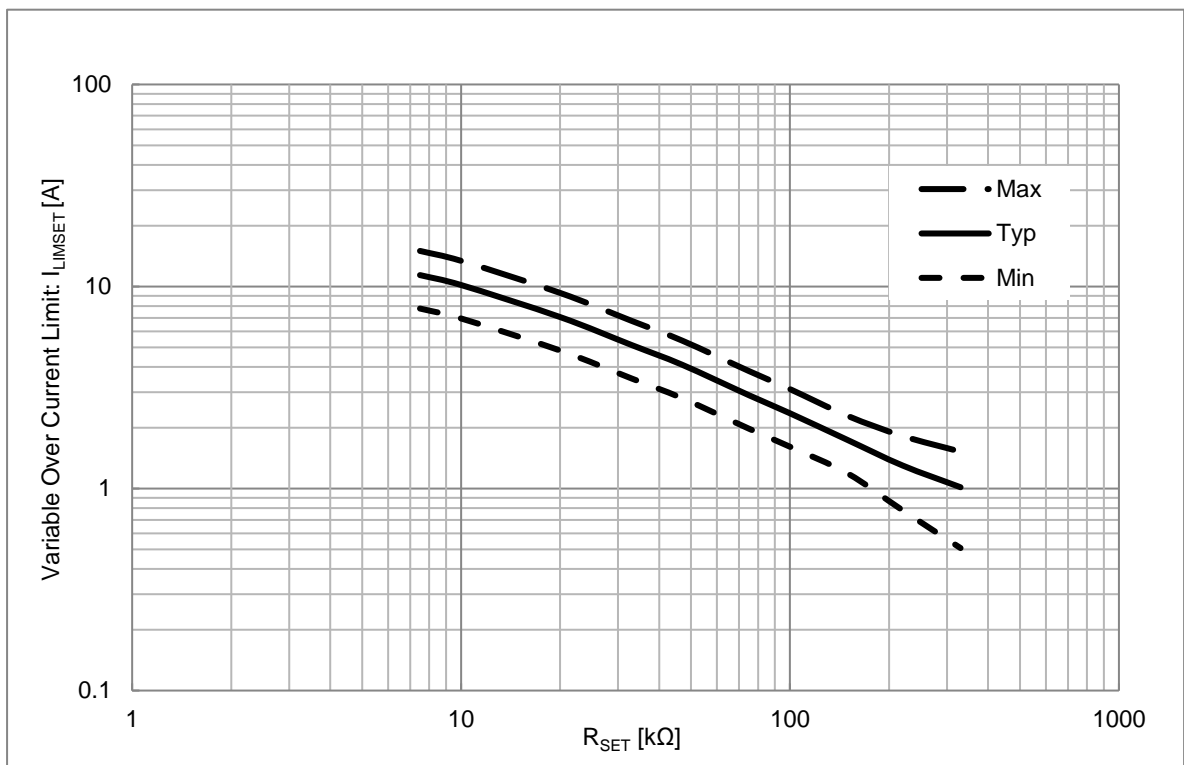

Figure 35. Variable Over Current Limit vs R_{SET}

Function Description – continued

2.3 Variable Over Current Limit Mask Time Setting

The variable over current mask time (t_{DLY}) can be set by using external capacitor C_{DLY} . t_{DLY} is the switching time from the over current detected timing until the over current limit value (I_{LIMSET}) set by R_{SET} .

The approximate expressions for variable over current mask time (t_{DLY}) are shown below.

$$t_{DLY_Max} = 0.28 \times \frac{C_{DLY}}{10^{-6}} \quad [s]$$

$$t_{DLY_Typ} = 0.20 \times \frac{C_{DLY}}{10^{-6}} \quad [s]$$

$$t_{DLY_Min} = 0.12 \times \frac{C_{DLY}}{10^{-6}} \quad [s]$$

C_{DLY} : External Capacitor Value
 t_{DLY} : Variable Over Current Mask Time

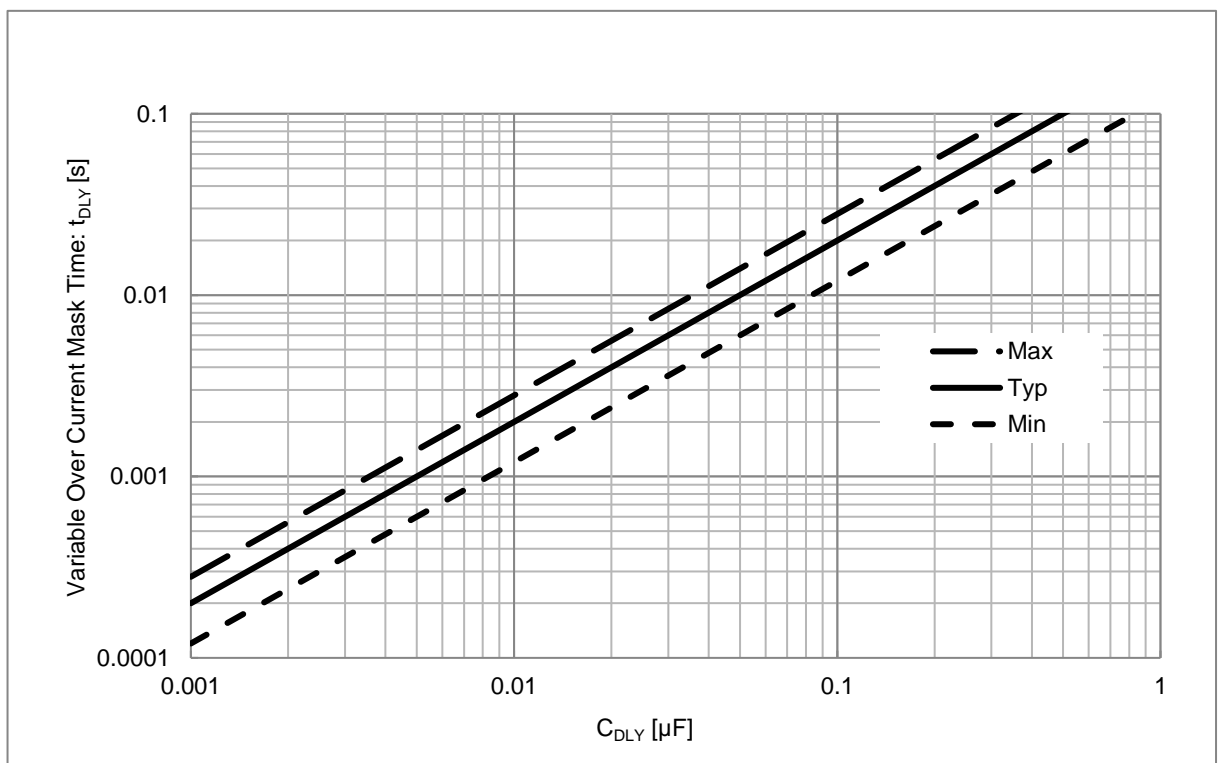

Figure 36. Variable Over Current Mask Time vs C_{DLY}

2.4 The SET Pin and the DLY Pin Setting

The DLY pin can be used by GND short^(Note 1) or Open.

DLY = GND: The variable over current limit is disabled and only fixed over current limit is operational.
 In this case, please set the SET pin OPEN or connect a resistor with 7.5 kΩ or above.

DLY = OPEN: Variable over current mask time is 10 μs or less.

(Note 1) Please short to GND of IC.

Function Description – continued

3. Open Load Detection

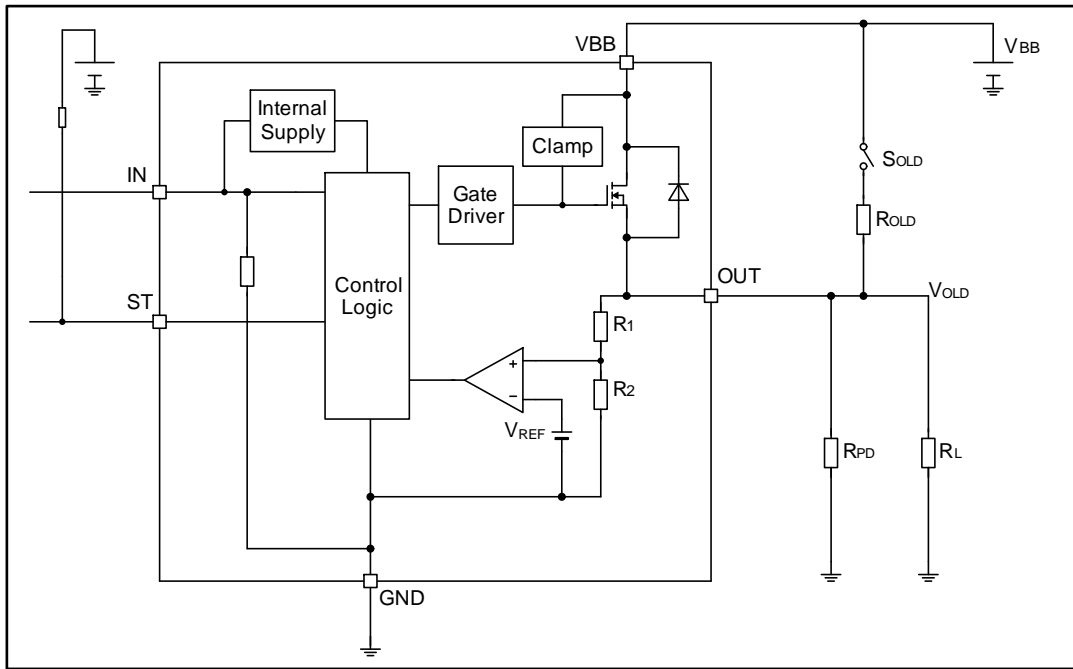

Figure 37. Open Load Detection Block Diagram

Open load can be detected by connecting an external resistance R_{OLD} between power supply V_{BB} and output (the OUT pin) and connecting an external pulled down resistance R_{PD} between GND and output.

To reduce the standby current of the system, an open load resistance switch S_{OLD} is recommended.

The resistance R_{PD} is 4.3 k Ω or less recommended. Because output OUT not decline to GND when R_L value is large.

The value of external resistance R_{OLD} is decided based on used minimum power supply voltage (V_{BB}), external resistance R_{PD} and open detection voltage V_{OLD} .

The equation for calculating the R_{OLD} value is shown below.

$$R_{OLD} < \frac{V_{BB} \times R_{PD}}{V_{OLD(Max)}} - R_{PD} \text{ } [\Omega]$$

When R_{PD} is 4.3 k Ω , the above formula is summarized as follows.

$$R_{OLD} < V_{BB} \times 1.075 \times 10^3 - 4.3 \times 10^3 \text{ } [\Omega]$$

R_{OLD} value is fell below the above calculated result.

Function Description – continued

4. Thermal Shutdown, ΔT_j Protection Detection

4.1 Thermal Shutdown Protection

This IC has a built-in thermal shutdown protection function. When the IC temperature is 175 °C (Typ) or more, the output is OFF. Diagnostic output (ST) outputs High. When the IC temperature falls below the 160 °C (Typ) or less, the output is automatically restored to normal operation.

4.2 ΔT_j Protection

This IC has a built-in ΔT_j protection function that turns OFF the output when the temperature difference (T_{DTJ}) between the POWER-MOS unit ($T_{POWER-MOS}$) and the control unit (T_{AMB}) in the IC is 120 °C (Typ) or more. ΔT_j protection also has a built-in hysteresis (T_{DTJHYS}) that returns the output to normal state when the temperature difference becomes 30 °C (Typ) or less.

Figure 38 shows the timing chart of thermal shutdown protection and ΔT_j protection during output short to GND fault.

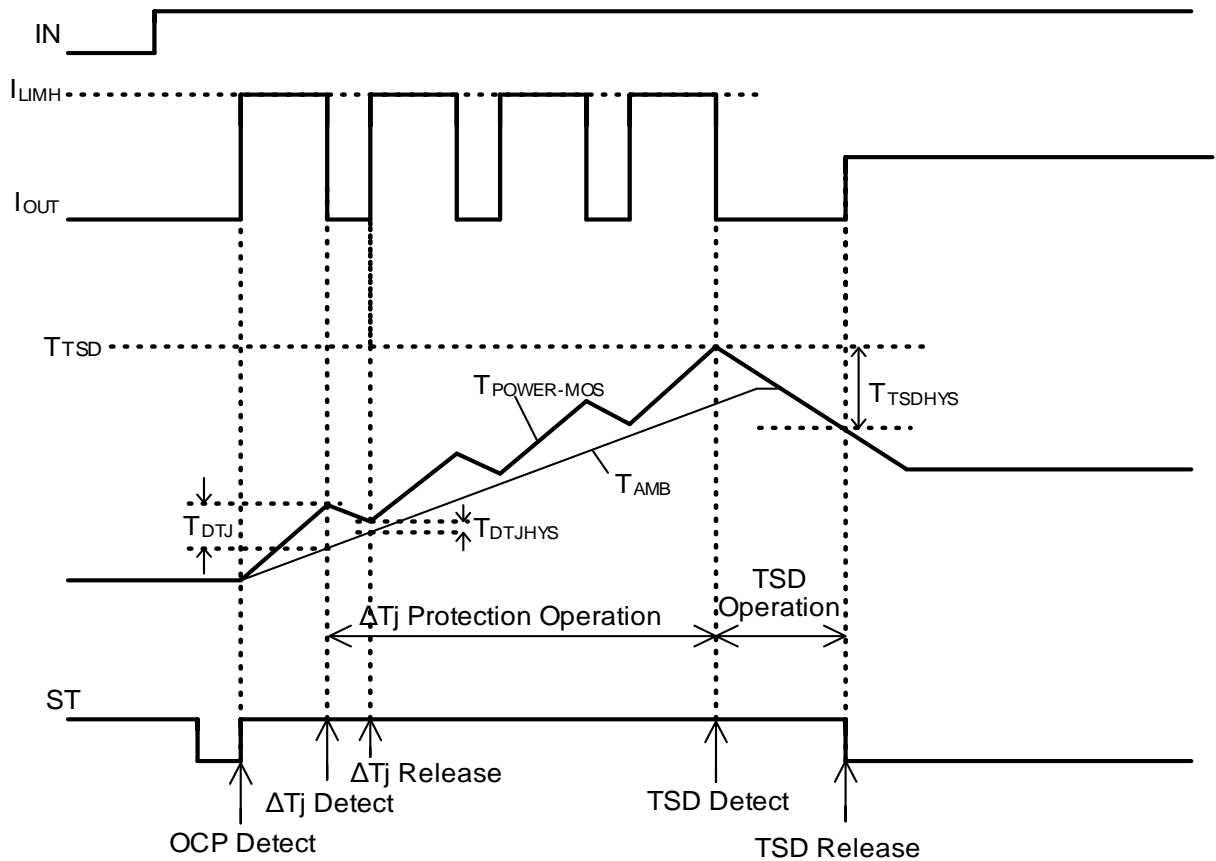

Figure 38. Thermal Shutdown Protection and ΔT_j Protection Timing Chart

Function Description – continued

5. Other Protection

5.1 GND Open Protection

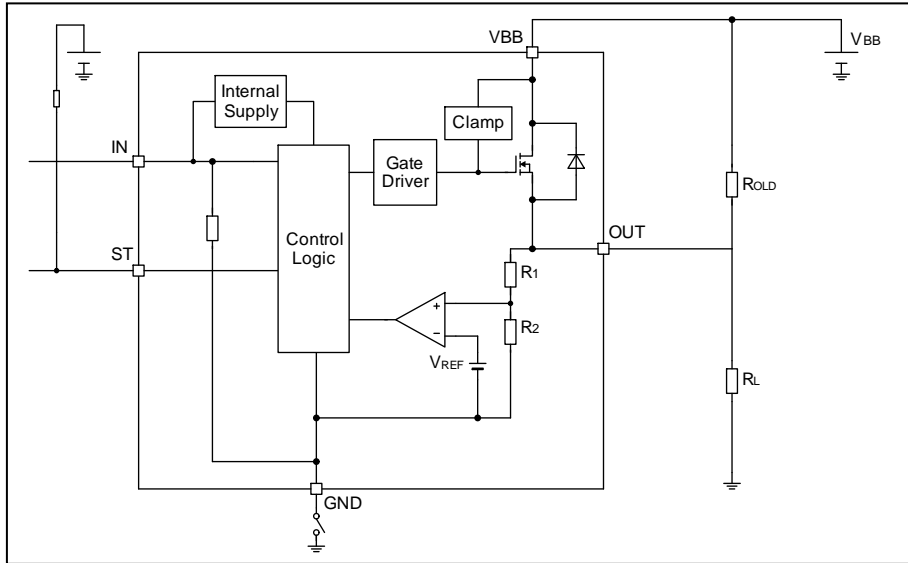

Figure 39. GND Open Protection Block Diagram

When the GND of the IC is open, the output switches OFF regardless of IN voltage.
 (However, the self-diagnosis output ST is invalid.)
 When an inductive load is connected, active clamp operates when the GND pin becomes open.

5.2 MCU I/O Protection

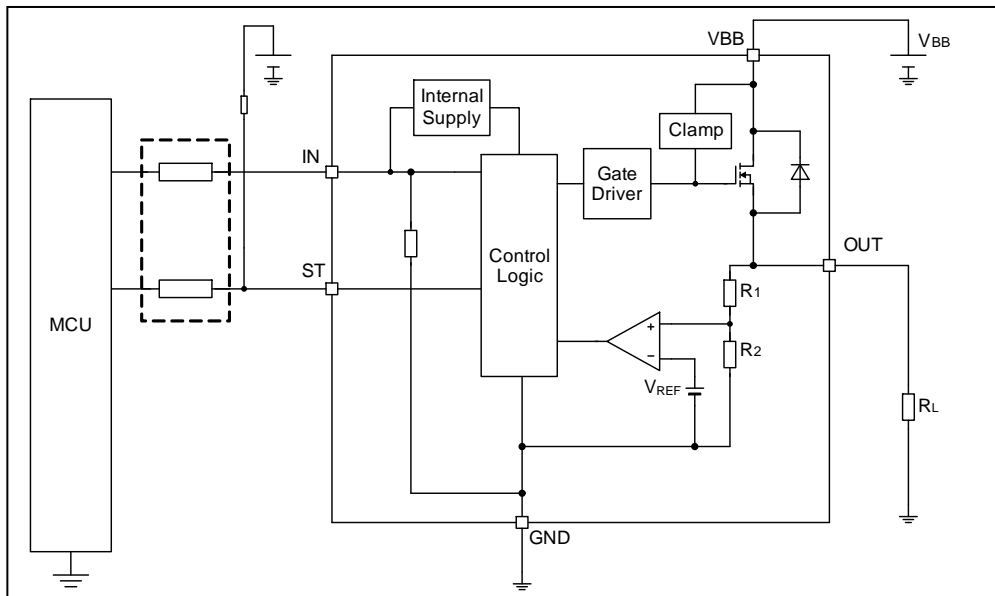
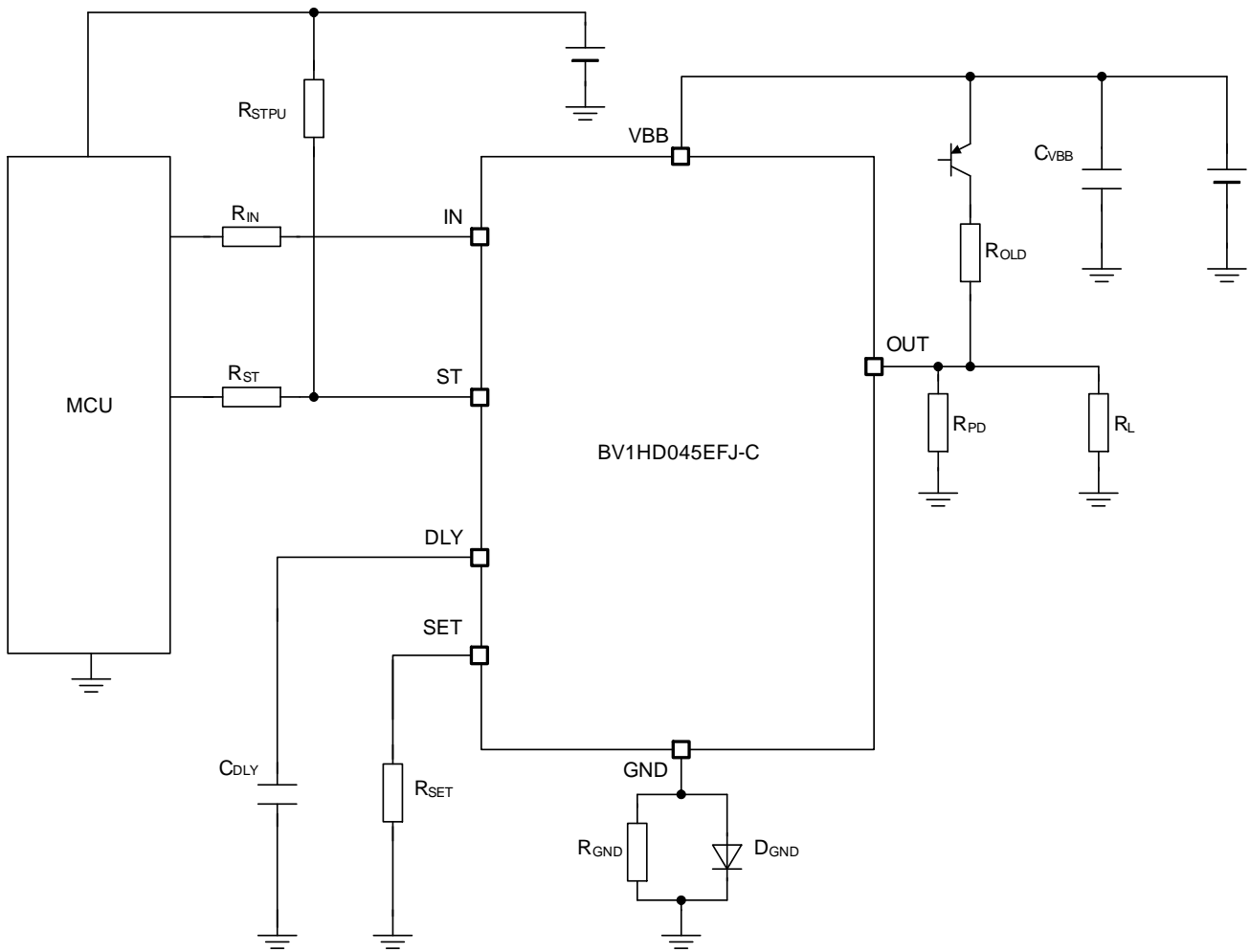

Figure 40. MCU I/O Protection

Negative surge voltage to the IN pin, the ST pin may cause damage to the MCU's I/O pins. In order to prevent those damages, it is recommended to insert limiting resistors between IC pins and MCU.

Applications Example



Symbol	Value MCU Voltage: 5 V ^(Note 1) ^(Note 2)	Purpose
R _{IN}	4.7 kΩ	Limit resistance for negative surge
R _{ST}	4.7 kΩ	Limit resistance for negative surge
R _{STPU}	10 kΩ	Pull up ST pin to MCU power supply, these pins are open drain output
R _{SET}	47 kΩ	For variable over current limit value ^(Note 3)
C _{VBB}	10 μF	For battery line voltage spike filter
C _{DLY}	0.1 μF	For variable over current mask time ^(Note 3)
R _{GND}	1 kΩ	For current limit for reverse battery connection
D _{GND}	-	BV1HD045EFJ-C protection for reverse battery connection
R _{PD}	4.3 kΩ	For output pulled down
R _{OLD}	2 kΩ	For open load detection

(Note 1) Please set R_{IN} and MCU voltage according to the rule of the electrical characteristic input department V_{IN}. Particularly, when you use 3.3 V MCU, please set them to satisfy High level input voltage (V_{INH}).

(Note 2) GND voltage of IC rises when you use R_{GND} and D_{GND}.
When GND voltage of IC rises, the input voltage IN pin rises, too.
Please set a constant to satisfy the following formula and contents of Note 1 about the input voltage.
High level input voltage (V_{INH}) < MCU voltage - (R_{IN}) x High level input current (I_{INH}) - GND voltage

(Note 3) GND voltage of IC rises when you use R_{GND} and D_{GND}.
When GND voltage of IC rises, the voltage of the SET pin and the DLY pin of the variable overcurrent setting rises, too.
Please use it in consideration of rise in GND voltage.
It is available with a characteristic as it is showed in Figure 35 and Figure 36 when you connect R_{SET} and C_{DLY} to GND of IC.

I/O Equivalence Circuits

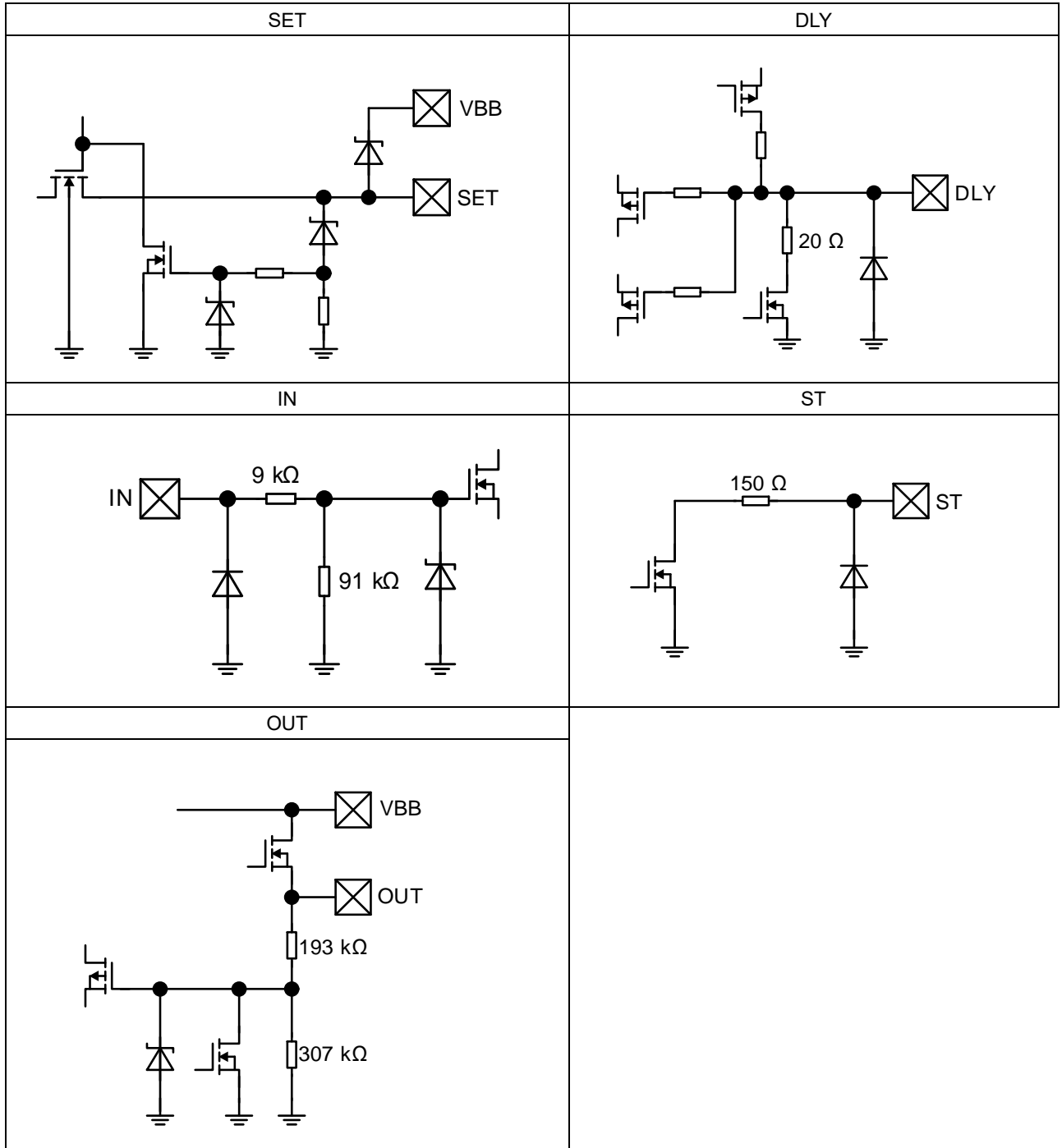

Resistance values shown in the diagrams above are typical values.

Operational Notes

1. Reverse Connection of Power Supply

Connecting the power supply in reverse polarity can damage the IC. Take precautions against reverse polarity when connecting the power supply, such as mounting an external diode between the power supply and the IC's power supply pins.

2. Power Supply Lines

Design the PCB layout pattern to provide low impedance supply lines. Furthermore, connect a capacitor to ground at all power supply pins. Consider the effect of temperature and aging on the capacitance value when using electrolytic capacitors.

3. Ground Voltage

Except for pins the output and the input of which were designed to go below ground, ensure that no pins are at a voltage below that of the ground pin at any time, even during transient condition.

4. Ground Wiring Pattern

When using both small-signal and large-current ground traces, the two ground traces should be routed separately but connected to a single ground at the reference point of the application board to avoid fluctuations in the small-signal ground caused by large currents. Also ensure that the ground traces of external components do not cause variations on the ground voltage. The ground lines must be as short and thick as possible to reduce line impedance.

5. Recommended Operating Conditions

The function and operation of the IC are guaranteed within the range specified by the recommended operating conditions. The characteristic values are guaranteed only under the conditions of each item specified by the electrical characteristics.

6. Inrush Current

When power is first supplied to the IC, it is possible that the internal logic may be unstable and inrush current may flow instantaneously due to the internal powering sequence and delays, especially if the IC has more than one power supply. Therefore, give special consideration to power coupling capacitance, power wiring, width of ground wiring, and routing of connections.

7. Testing on Application Boards

When testing the IC on an application board, connecting a capacitor directly to a low-impedance output pin may subject the IC to stress. Always discharge capacitors completely after each process or step. The IC's power supply should always be turned off completely before connecting or removing it from the test setup during the inspection process. To prevent damage from static discharge, ground the IC during assembly and use similar precautions during transport and storage.

8. Inter-pin Short and Mounting Errors

Ensure that the direction and position are correct when mounting the IC on the PCB. Incorrect mounting may result in damaging the IC. Avoid nearby pins being shorted to each other especially to ground, power supply and output pin. Inter-pin shorts could be due to many reasons such as metal particles, water droplets (in very humid environment) and unintentional solder bridge deposited in between pins during assembly to name a few.

9. Unused Input Pins

Input pins of an IC are often connected to the gate of a MOS transistor. The gate has extremely high impedance and extremely low capacitance. If left unconnected, the electric field from the outside can easily charge it. The small charge acquired in this way is enough to produce a significant effect on the conduction through the transistor and cause unexpected operation of the IC. So unless otherwise specified, unused input pins should be connected to the power supply or ground line.

10. Ceramic Capacitor

When using a ceramic capacitor, determine a capacitance value considering the change of capacitance with temperature and the decrease in nominal capacitance due to DC bias and others.

11. Thermal Shutdown Function (TSD)

This IC has a built-in thermal shutdown function that prevents heat damage to the IC. Normal operation should always be within the IC's maximum junction temperature rating. If however the rating is exceeded for a continued period, the junction temperature (T_j) will rise which will activate the TSD function that will turn OFF power output pins. When the T_j falls below the TSD threshold, the circuits are automatically restored to normal operation.

Note that the TSD function operates in a situation that exceeds the absolute maximum ratings and therefore, under no circumstances, should the TSD function be used in a set design or for any purpose other than protecting the IC from heat damage.

Operational Notes – continued**12. Over Current Protection Function (OCP)**

This IC incorporates an integrated overcurrent protection function that is activated when the load is shorted. This protection function is effective in preventing damage due to sudden and unexpected incidents. However, the IC should not be used in applications characterized by continuous operation or transitioning of the protection function.

13. Active Clamp Operation

The IC integrates the active clamp function to internally absorb the reverse energy which is generated when the inductive load is turned off. When the active clamp operates, the thermal shutdown function does not work. Decide a load so that the reverse energy is active clamp tolerance (refer to Figure 24. Active Clamp Energy vs Output Current) or under when inductive load is used.

14. Open Power Supply Pin

When the power supply pin (VBB) becomes open at ON (IN = High), the output is switched to OFF regardless of input voltage. If an inductive load is connected, the active clamp operates when VBB is open and becomes the same potential as that on the ground. At this time, the output voltage drops down to -48 V (Typ).

15. Open GND Pin

When the GND pin becomes open at ON (IN = High), the output is switched to OFF regardless of input voltage. If an inductive load is connected, the active clamp operates when the GND pin is open.

Ordering Information



Marking Diagram

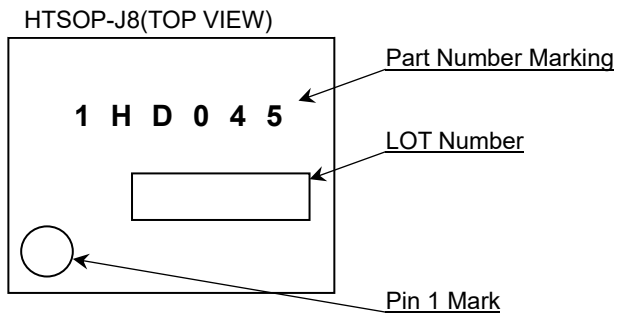

Physical Dimension and Packing Information

Package Name	HTSOP-J8
--------------	----------

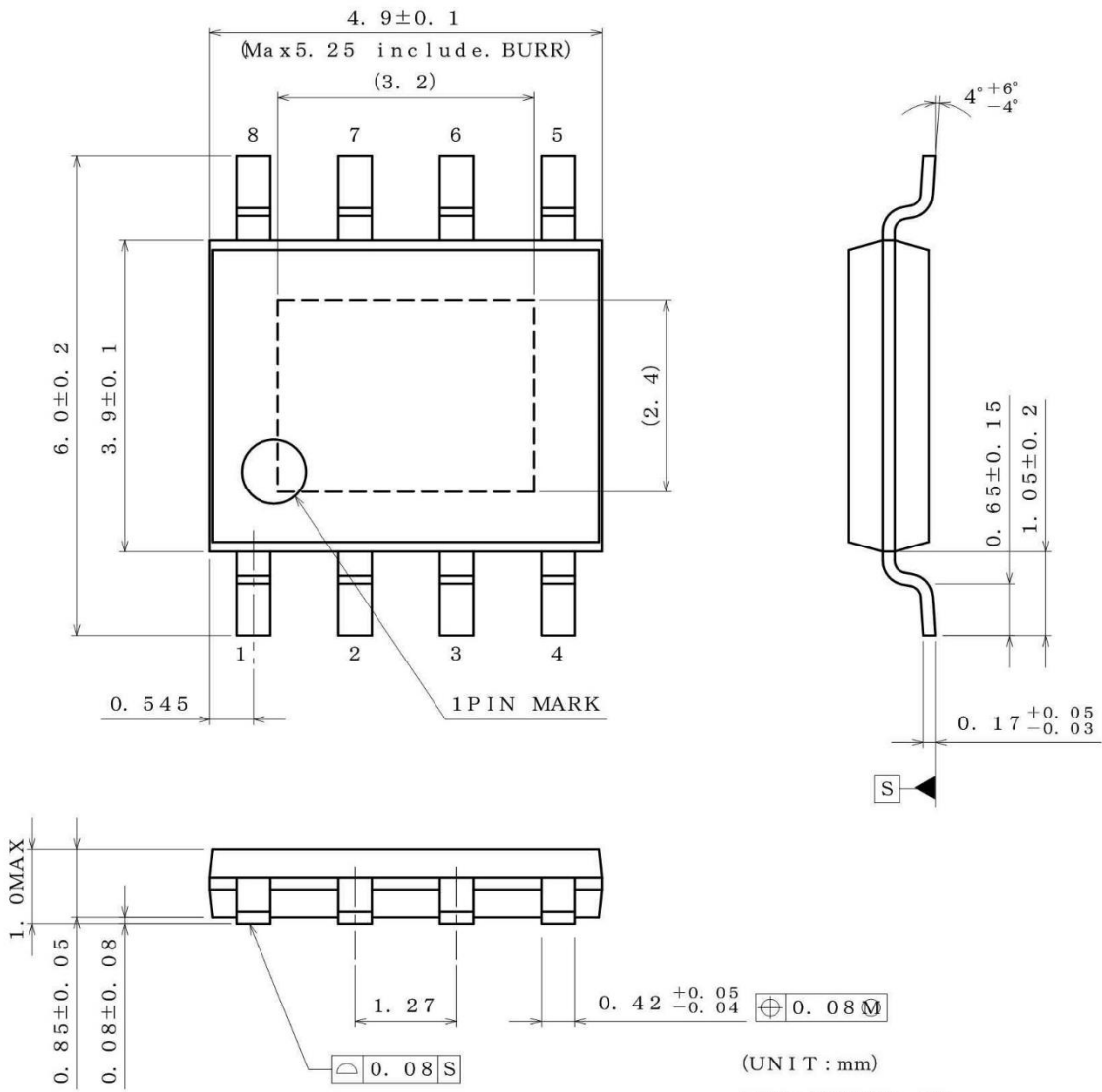

(UNIT : mm)

PKG : HTSOP-J8

Drawing No. EX169-5002-2

< Tape and Reel Information >

Tape	Embossed carrier tape
Quantity	2500pcs
Direction of feed	E2 The direction is the pin 1 of product is at the upper left when you hold reel on the left hand and you pull out the tape on the right hand

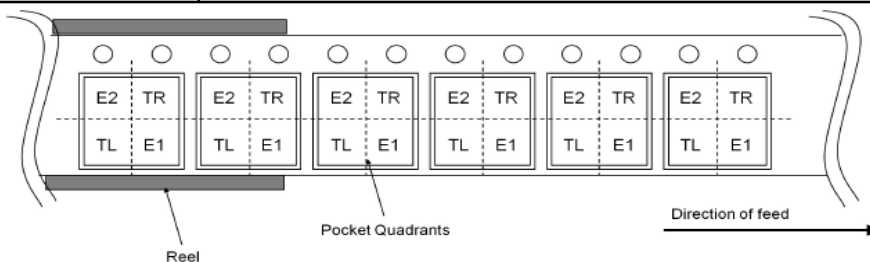

Revision History

Date	Revision	Changes
04.Mar.2021	001	New Release
02.Mar.2023	002	Page 3 Modify EXP-PAD description in Pin Description. Page 23 Note 1 about GND short is added. Page 27 MCU voltage is defined in Applications Example. Note 1, Note 2 and Note 3 are added.

Notice

Precaution on using ROHM Products

1. If you intend to use our Products in devices requiring extremely high reliability (such as medical equipment ^(Note 1), aircraft/spacecraft, nuclear power controllers, etc.) and whose malfunction or failure may cause loss of human life, bodily injury or serious damage to property ("Specific Applications"), please consult with the ROHM sales representative in advance. Unless otherwise agreed in writing by ROHM in advance, ROHM shall not be in any way responsible or liable for any damages, expenses or losses incurred by you or third parties arising from the use of any ROHM's Products for Specific Applications.

(Note1) Medical Equipment Classification of the Specific Applications

JAPAN	USA	EU	CHINA
CLASS III	CLASS III	CLASS II b	CLASS III
CLASS IV		CLASS III	

2. ROHM designs and manufactures its Products subject to strict quality control system. However, semiconductor products can fail or malfunction at a certain rate. Please be sure to implement, at your own responsibilities, adequate safety measures including but not limited to fail-safe design against the physical injury, damage to any property, which a failure or malfunction of our Products may cause. The following are examples of safety measures:
 - [a] Installation of protection circuits or other protective devices to improve system safety
 - [b] Installation of redundant circuits to reduce the impact of single or multiple circuit failure
3. Our Products are not designed under any special or extraordinary environments or conditions, as exemplified below. Accordingly, ROHM shall not be in any way responsible or liable for any damages, expenses or losses arising from the use of any ROHM's Products under any special or extraordinary environments or conditions. If you intend to use our Products under any special or extraordinary environments or conditions (as exemplified below), your independent verification and confirmation of product performance, reliability, etc. prior to use, must be necessary:
 - [a] Use of our Products in any types of liquid, including water, oils, chemicals, and organic solvents
 - [b] Use of our Products outdoors or in places where the Products are exposed to direct sunlight or dust
 - [c] Use of our Products in places where the Products are exposed to sea wind or corrosive gases, including Cl₂, H₂S, NH₃, SO₂, and NO₂
 - [d] Use of our Products in places where the Products are exposed to static electricity or electromagnetic waves
 - [e] Use of our Products in proximity to heat-producing components, plastic cords, or other flammable items
 - [f] Sealing or coating our Products with resin or other coating materials
 - [g] Use of our Products without cleaning residue of flux (Exclude cases where no-clean type fluxes is used. However, recommend sufficiently about the residue.); or Washing our Products by using water or water-soluble cleaning agents for cleaning residue after soldering
 - [h] Use of the Products in places subject to dew condensation
4. The Products are not subject to radiation-proof design.
5. Please verify and confirm characteristics of the final or mounted products in using the Products.
6. In particular, if a transient load (a large amount of load applied in a short period of time, such as pulse, is applied, confirmation of performance characteristics after on-board mounting is strongly recommended. Avoid applying power exceeding normal rated power; exceeding the power rating under steady-state loading condition may negatively affect product performance and reliability.
7. De-rate Power Dissipation depending on ambient temperature. When used in sealed area, confirm that it is the use in the range that does not exceed the maximum junction temperature.
8. Confirm that operation temperature is within the specified range described in the product specification.
9. ROHM shall not be in any way responsible or liable for failure induced under deviant condition from what is defined in this document.

Precaution for Mounting / Circuit board design

1. When a highly active halogenous (chlorine, bromine, etc.) flux is used, the residue of flux may negatively affect product performance and reliability.
2. In principle, the reflow soldering method must be used on a surface-mount products, the flow soldering method must be used on a through hole mount products. If the flow soldering method is preferred on a surface-mount products, please consult with the ROHM representative in advance.

For details, please refer to ROHM Mounting specification

Precautions Regarding Application Examples and External Circuits

1. If change is made to the constant of an external circuit, please allow a sufficient margin considering variations of the characteristics of the Products and external components, including transient characteristics, as well as static characteristics.
2. You agree that application notes, reference designs, and associated data and information contained in this document are presented only as guidance for Products use. Therefore, in case you use such information, you are solely responsible for it and you must exercise your own independent verification and judgment in the use of such information contained in this document. ROHM shall not be in any way responsible or liable for any damages, expenses or losses incurred by you or third parties arising from the use of such information.

Precaution for Electrostatic

This Product is electrostatic sensitive product, which may be damaged due to electrostatic discharge. Please take proper caution in your manufacturing process and storage so that voltage exceeding the Products maximum rating will not be applied to Products. Please take special care under dry condition (e.g. Grounding of human body / equipment / solder iron, isolation from charged objects, setting of Ionizer, friction prevention and temperature / humidity control).

Precaution for Storage / Transportation

1. Product performance and soldered connections may deteriorate if the Products are stored in the places where:
 - [a] the Products are exposed to sea winds or corrosive gases, including Cl₂, H₂S, NH₃, SO₂, and NO₂
 - [b] the temperature or humidity exceeds those recommended by ROHM
 - [c] the Products are exposed to direct sunshine or condensation
 - [d] the Products are exposed to high Electrostatic
2. Even under ROHM recommended storage condition, solderability of products out of recommended storage time period may be degraded. It is strongly recommended to confirm solderability before using Products of which storage time is exceeding the recommended storage time period.
3. Store / transport cartons in the correct direction, which is indicated on a carton with a symbol. Otherwise bent leads may occur due to excessive stress applied when dropping of a carton.
4. Use Products within the specified time after opening a humidity barrier bag. Baking is required before using Products of which storage time is exceeding the recommended storage time period.

Precaution for Product Label

A two-dimensional barcode printed on ROHM Products label is for ROHM's internal use only.

Precaution for Disposition

When disposing Products please dispose them properly using an authorized industry waste company.

Precaution for Foreign Exchange and Foreign Trade act

Since concerned goods might be fallen under listed items of export control prescribed by Foreign exchange and Foreign trade act, please consult with ROHM in case of export.

Precaution Regarding Intellectual Property Rights

1. All information and data including but not limited to application example contained in this document is for reference only. ROHM does not warrant that foregoing information or data will not infringe any intellectual property rights or any other rights of any third party regarding such information or data.
2. ROHM shall not have any obligations where the claims, actions or demands arising from the combination of the Products with other articles such as components, circuits, systems or external equipment (including software).
3. No license, expressly or implied, is granted hereby under any intellectual property rights or other rights of ROHM or any third parties with respect to the Products or the information contained in this document. Provided, however, that ROHM will not assert its intellectual property rights or other rights against you or your customers to the extent necessary to manufacture or sell products containing the Products, subject to the terms and conditions herein.

Other Precaution

1. This document may not be reprinted or reproduced, in whole or in part, without prior written consent of ROHM.
2. The Products may not be disassembled, converted, modified, reproduced or otherwise changed without prior written consent of ROHM.
3. In no event shall you use in any way whatsoever the Products and the related technical information contained in the Products or this document for any military purposes, including but not limited to, the development of mass-destruction weapons.
4. The proper names of companies or products described in this document are trademarks or registered trademarks of ROHM, its affiliated companies or third parties.

General Precaution

1. Before you use our Products, you are requested to carefully read this document and fully understand its contents. ROHM shall not be in any way responsible or liable for failure, malfunction or accident arising from the use of any ROHM's Products against warning, caution or note contained in this document.
2. All information contained in this document is current as of the issuing date and subject to change without any prior notice. Before purchasing or using ROHM's Products, please confirm the latest information with a ROHM sales representative.
3. The information contained in this document is provided on an "as is" basis and ROHM does not warrant that all information contained in this document is accurate and/or error-free. ROHM shall not be in any way responsible or liable for any damages, expenses or losses incurred by you or third parties resulting from inaccuracy or errors of or concerning such information.