

Low Duty LCD Segment Driver For Automotive COG Application

BU91R64CH-M Max 320 Segments (80SEG x 4COM)

General Description

BU91R64CH-M is a 1/4, 1/3, 1/2 Duty or Static COG type LCD driver that can be used for automotive applications and can drive up to 320 LCD Segments.

This driver can be cascaded up-to maximum of 4 drivers for larger LCD panel application.

It supports VA LCD displays, which has better optical performance with higher LCD voltage driving and higher frame frequency driving.

This driver includes read function for display data and command registers, wherein it is possible to detect malfunction due to noise.

It can also support other error detections such as interface checksum detection, glass breaking detection, logic error detection and SEG / COM toggle detection.

A defective mounting of COG can easily be controlled by using terminals to measure ITO resistance.

It can support operating temperature of up to +105 °C and compliant for AEC-Q100, as required for Automotive Application.

Features

- AEC-Q100 Compliant *(Note 1)*
- 1/4, 1/3, 1/2 Duty or Static Drive Selectable
 - 1/4 Duty Drive: Max 320 Segments
 - 1/3 Duty Drive: Max 240 Segments
 - 1/2 Duty Drive: Max 160 Segments
 - Static Drive: Max 80 Segments
- Integrated Buffer AMP for LCD Driving
- Integrated Oscillator Circuit and Software Programmable Frame Frequency from 66 Hz to 488 Hz
- Support External Clock Input
- Integrated EVR Function to Adjust LCD Contrast
- Integrated Power On Reset Circuit
- No External Components
- Low Power Consumption Design
- Support Display Inhibit Control
- Configurable COM Driving Order
- Support Max 4 Drivers Cascade Connection (BU91R64 / R65 / R66CH-M Available)
- Support Register and Display Data Read-back Function
- Support LCD Contact Resistance Measurement
- Support Error Detection and Status Read Function
 - Glass Breaking Detection
 - Interface Checksum
 - Logic Error Detection
 - SEG / COM Toggle Detection

(Note 1) Quality Information:

There is data when LSI was put on a temporary package.
Please use it as reference data.

Key Specifications

- Supply Voltage Range: +2.7 V to +6.0 V
- LCD Drive Power Supply Range: +2.7 V to +6.0 V
- Operating Temperature Range: -40 °C to +105 °C
- Max Segments: 320 Segments
- Display Duty: 1/4, 1/3, 1/2, Static Selectable
- Bias: 1/2, 1/3 Selectable
- Interface: 2-wire / 3-wire Serial Interface Selectable

Special Characteristics

- ESD(HBM) *(Note 2)*: ±2,000 V(Typ)
- Latch-up Current *(Note 2)*: ±100 mA(Typ)

(Note 2) There is data when LSI was put on a temporary package.

Applications

- Instrument Clusters
 - Climate Controls
 - Car Audios / Radios
 - Meters
 - White Goods
 - Healthcare Products
 - Battery Operated Applications
- etc.

Package

Au Bump Chip

Contents

General Description	1
Features	1
Key Specifications.....	1
Special Characteristics.....	1
Applications	1
Package	1
Contents.....	2
Typical Application Circuit.....	6
Block Diagram	6
Terminal Description.....	7
Recommended ITO Layout.....	8
Terminal Resistance	10
PAD Arrangement	11
Dimension	12
PAD Coordinates	13
Absolute Maximum Ratings (VSS = 0V).....	15
Recommended Operating Conditions	15
Electrical Characteristics	16
DC Characteristics.....	16
Oscillation Characteristics	17
2-wire Serial Interface Characteristics	18
3-wire Serial Interface Characteristics	19
I/O Equivalence Circuit.....	20
MCU Interface	21
START and STOP Condition (2-wire).....	21
Acknowledge (ACK) (2-wire).....	21
Command / Display Data Transfer Method (2-wire).....	22
Display Data Transfer Method (2-wire)	23
Display Data Read-back Method (2-wire)	24
Command Registers Read-back Method (2-wire).....	25
Command / Display Data Transfer Method (3-SPI).....	26
Command Transfer Method (3-SPI).....	26
Display Data Transfer Method (3-SPI)	27
Display Data Read-back Method (3-SPI)	28
Command Registers Read-back Method (3-SPI)	28
OSC (Oscillator).....	29
SYNC CTRL (Multi-chip Structure).....	30
LCD Driver Voltage Generator / LCD Bias Selector	33
POR and Reset Initialize Condition.....	33
Blink Control (Blink Timing Generator)	33
Error Detection.....	34
Glass Breaking Detection.....	35
Checksum Detection.....	37
Logic Error Detection.....	38
SEG / COM Toggle Detection.....	39
Contact Resistance Check.....	39
Command / Function List.....	40
Detailed Command Description	40
1. Mode Set 1 (MODESET1).....	40
2. Address Set (ADSET)	41
3. Sub Address Set (SADSET)	41
4. Frame Rate Set (FRSET).....	42

5. Blink Control1 (BLKCTL1)	43
6. Blink Control2 (BLKCTL2)	43
7. Command Extension (CMDXTN)	44
8. Software Reset (SWRST)	44
9. Mode Set 2 (MODESET2)	45
10. Mode Set 3 (MODESET3)	45
11. Contrast Setting (CNTSET)	46
12. Read Control (RDCTL)	47
13. Checksum (CHKSUM)	47
14. COM Set (COMSET)	48
LCD Driving Waveform	49
1/3 Bias, 1/4 Duty Drive	49
1/2 Bias, 1/4 Duty Drive	50
1/3 Bias, 1/3 Duty Drive	51
1/2 Bias, 1/3 Duty Drive	52
1/3 Bias, 1/2 Duty Drive	53
1/2 Bias, 1/2 Duty Drive	54
Static Drive	55
Example of Display Data	56
Initialize Sequence	57
Start Sequence	58
Start Sequence Example1	58
Start Sequence Example2	59
Cautions in Power On / Off	60
Display Off Operation in External Clock Mode	61
In Multi-chip Structure in Internal Clock Mode	61
Note on The Multiple Device Connection to 2-wire Serial Interface	62
Note in Case that the SDA is stuck at LOW	62
Operational Notes	63
1. Reverse Connection of Power Supply	63
2. Power Supply Lines	63
3. Ground Voltage	63
4. Ground Wiring Pattern	63
5. Recommended Operating Conditions	63
6. Inrush Current	63
7. Testing on Application Boards	63
8. Inter-pin Short and Mounting Errors	63
9. Unused Input Pins	63
10. Regarding the Input Pin of the IC	63
11. Ceramic Capacitor	63
12. Disturbance Light	64
Ordering Information	65
Minimum Order Quantity (MOQ)	65
Marking Diagram	65
Packing Quantity	66
Pellet Drawing	66
Package Condition	67
Physical Dimension Tray Information	68
Revision History	69

Figure 1. PAD / Bump Information.....	12
Figure 2. Operating Current vs Power Supply Voltage	16
Figure 3. Frame Frequency vs Temperature.....	17
Figure 4. Interface Timing of 2-wire Serial Interface	18
Figure 5. Interface Timing of 3-wire Serial Interface	19
Figure 6. 2-wire Command / Data Transfer Format	21
Figure 7. Acknowledge Timing	21
Figure 8. Wrong Slave Address Case.....	21
Figure 9. 2-wire Interface Protocol	22
Figure 10. Case of Exiting Data Transfer State in 2-wire	22
Figure 11. Display Data Transfer in 2-wire.....	23
Figure 12. DDRAM Address Map in Write Mode	23
Figure 13. Display Data Read-back in 2-wire.....	24
Figure 14. Bit-Assignment in Display Data Read-back in 2-wire	24
Figure 15. DDRAM Address Map in Read Mode.....	24
Figure 16. Command Registers Read-back Method in 2-wire.....	25
Figure 17. Command / Data Transfer in 3-SPI Command / Data Transfer in 3-SPI.....	26
Figure 18. Escape from Data Transfer Condition in 3-SPI	26
Figure 19. Case of Less Than 8-bit Data Transfer in 3-SPI.....	26
Figure 20. Display Data Transfer and Bit Assignment in 3-SPI	27
Figure 21. Case of Less Than 4-bit Write Data Transfer in 3-SPI.....	27
Figure 22. Display Data Read-back in 3-SPI.....	28
Figure 23. Bit Assignment in Display Data Read-back in 3-SPI	28
Figure 24. Command Registers Read-back in 3-SPI.....	28
Figure 25. Internal Clock Mode	29
Figure 26. External Clock Mode.....	29
Figure 27. Synchronization of Multi-chip Cascaded Connection	31
Figure 28. Example of Cascaded Connection.....	32
Figure 29. Example Different Duty Drive Panel Configuration.....	32
Figure 30. Bank Blink Mode Function (Blink Frequency as 32 Frame Case)	33
Figure 31. DDRAM Address Map of Blink Area (Bank Blink Mode)	33
Figure 32. Detection Block and Data Path	34
Figure 33. Glass Breaking Detection.....	35
Figure 34. Sequence of Glass Breaking Detection.....	36
Figure 35. Sequence of Checksum Detection.....	37
Figure 36. Example of Checksum Calculation	37
Figure 37. Sequence of Logic Error Detection	38
Figure 38. Sequence of SEG / COM Toggle Detection.....	39
Figure 39. DUMMY PADs for the Contact Resistance Measurement	39
Figure 40. COM Scan Direction Image.....	48
Figure 41. Example COM Line Pattern.....	56
Figure 42. Example SEG Line Pattern.....	56
Figure 43. Example Display Pattern	56
Figure 44. Recommended Power On / Off Sequence.....	60
Figure 45. Power On / Off Waveform.....	60
Figure 46. Dummy Clock / STOP / START Condition	60
Figure 47. CSB Timing	60
Figure 48. External Clock Stop Timing	61
Figure 49. DISPOFF Sequence in Multi-chip Structure	61
Figure 50. Example of BUS Connection	62
Figure 51. SDA Output Cell Structure.....	62
Figure 52. Recovery Sequence from SDA Stuck.....	62

Table 1. Dimension (Completion Size).....	12
Table 2. Bump Specs and Dimensions.....	12
Table 3. Command Registers Map for Read-back.....	25
Table 4. Detection Functions.....	34
Table 5. Frame Frequency (Internal Clock Mode).....	42
Table 6. Frame Frequency (External Clock Mode).....	42
Table 7. V0 Voltage Setting.....	46
Table 8. DDRAM Data Example.....	56

Typical Application Circuit

2-wire Serial Interface

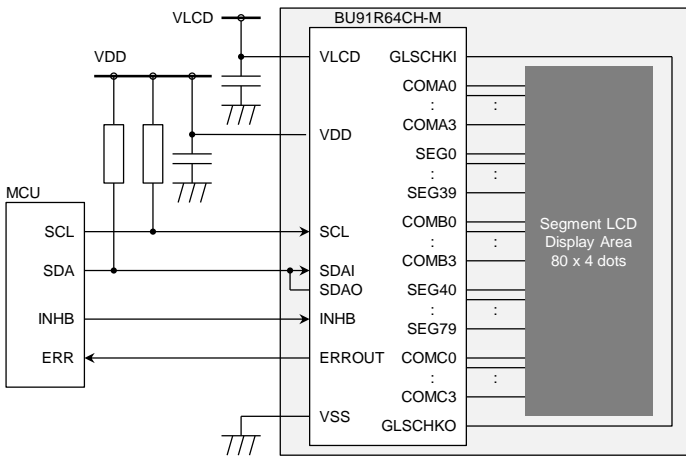

3-wire Serial Interface

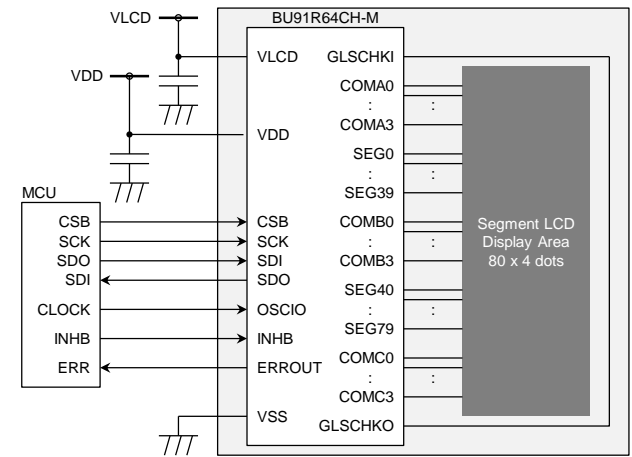

Insert capacitance (C ≥ 0.1μF) between VDD / VLCD and VSS

Block Diagram

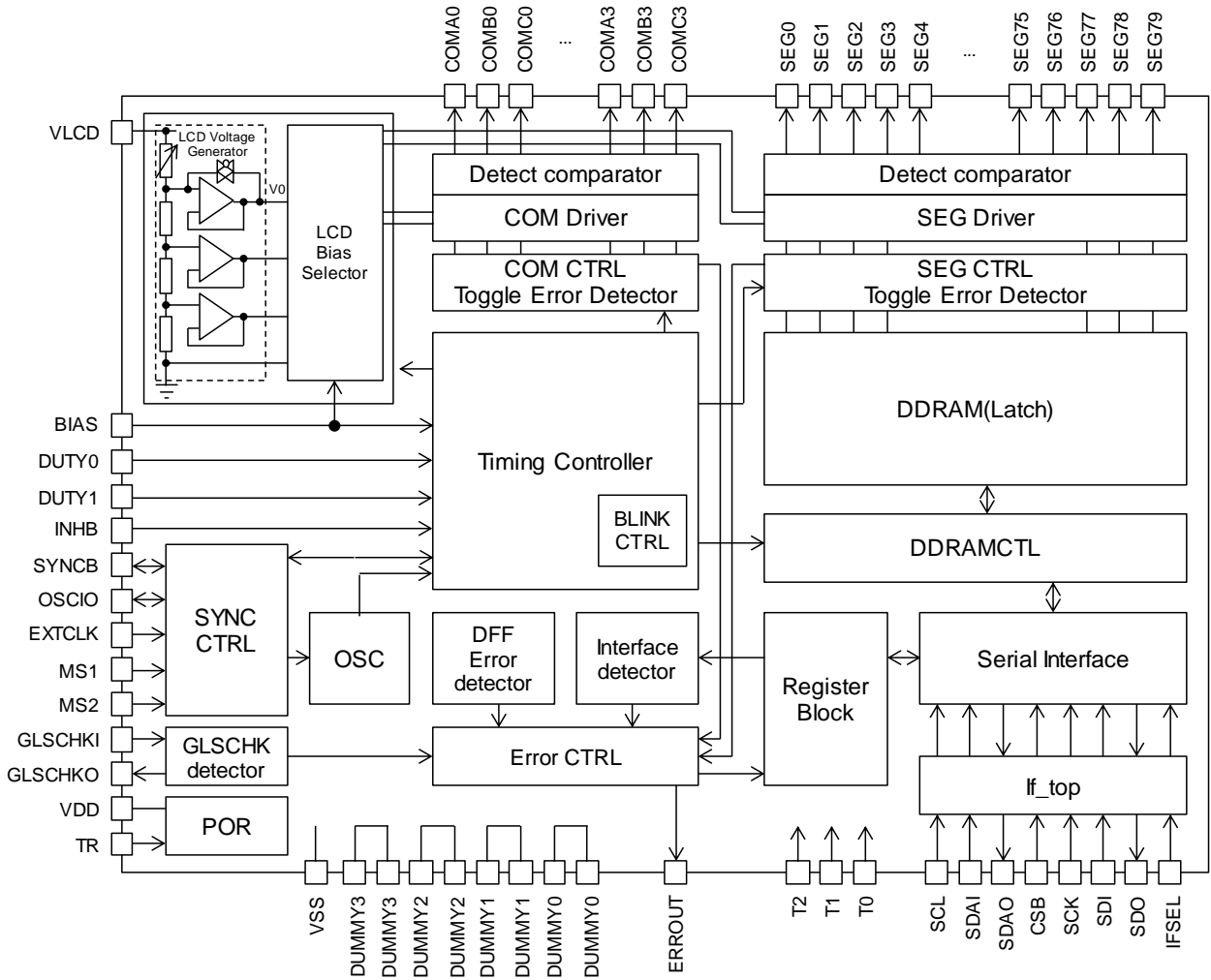

Terminal Description

Terminal Name	I/O	Function	Handling when unused																												
VDD	I	Power supply for logic	-																												
VLCD	I	Power supply for LCD driving circuit	-																												
VSS	I	Ground	-																												
MS1	I	Single- / Multi-chip setting <table border="1" style="width: 100%; border-collapse: collapse;"> <thead> <tr> <th rowspan="2">MS2</th> <th rowspan="2">MS1</th> <th colspan="2">2-wire Interface</th> <th>3-wire Interface</th> </tr> <tr> <th>Function</th> <th>Slave Address[7:1]</th> <th>Function</th> </tr> </thead> <tbody> <tr> <td>VSS</td> <td>VSS</td> <td>Master</td> <td>0111110 / 0111000</td> <td>Master</td> </tr> <tr> <td>VSS</td> <td>VDD</td> <td>Slave1</td> <td>0111111 / 0111001</td> <td>Slave1</td> </tr> <tr> <td>VDD</td> <td>VSS</td> <td>Slave2</td> <td>0111110 / 0111000</td> <td>Slave2</td> </tr> <tr> <td>VDD</td> <td>VDD</td> <td>Slave3</td> <td>0111111 / 0111001</td> <td>Slave3</td> </tr> </tbody> </table>	MS2	MS1	2-wire Interface		3-wire Interface	Function	Slave Address[7:1]	Function	VSS	VSS	Master	0111110 / 0111000	Master	VSS	VDD	Slave1	0111111 / 0111001	Slave1	VDD	VSS	Slave2	0111110 / 0111000	Slave2	VDD	VDD	Slave3	0111111 / 0111001	Slave3	VDD / VSS
MS2	MS1	2-wire Interface			3-wire Interface																										
		Function	Slave Address[7:1]	Function																											
VSS	VSS	Master	0111110 / 0111000	Master																											
VSS	VDD	Slave1	0111111 / 0111001	Slave1																											
VDD	VSS	Slave2	0111110 / 0111000	Slave2																											
VDD	VDD	Slave3	0111111 / 0111001	Slave3																											
MS2	I		VDD / VSS																												
EXTCLK	I	Clock mode setting VDD: External Clock Mode, VSS: Internal Clock Mode	VDD / VSS																												
OSCIO	I/O	Clock input / output setting External Clock Mode: input of external clock Internal Clock Mode: output of internal clock	OPEN																												
SYNCB	I/O	Synchronous signal input / output for multi-chip mode Master: Synchronous signal output Slave: master SYNCB signal input	OPEN																												
IFSEL	I	MCU Interface select VDD: 3-wire Serial Interface VSS: 2-wire Serial Interface	VDD / VSS																												
SDAI	I	Serial data input for 2-wire Serial Interface	VSS																												
SDAO	O	Serial data output for 2-wire Serial Interface	OPEN																												
SCL	I	Serial clock for 2-wire Serial Interface	VSS																												
CSB	I	Chip select for 3-wire Serial Interface	VSS																												
SCK	I	Serial clock for 3-wire Serial Interface	VSS																												
SDI	I	Serial data input for 3-wire Serial Interface	VSS																												
SDO	O	Serial data output for 3-wire Serial Interface	OPEN																												
INH B	I	Inhibit display status in spite of Display On by command setting VDD: Keep display status by command setting VSS: Inhibit display status. All SEG and COM terminals output VSS level.	VDD																												
DUTY0	I	Duty Drive select <table border="1" style="width: 100%; border-collapse: collapse;"> <thead> <tr> <th>DUTY1</th> <th>DUTY0</th> <th>Duty Drive</th> </tr> </thead> <tbody> <tr> <td>VSS</td> <td>VSS</td> <td>1/4 Duty Drive</td> </tr> <tr> <td>VSS</td> <td>VDD</td> <td>1/3 Duty Drive</td> </tr> <tr> <td>VDD</td> <td>VSS</td> <td>1/2 Duty Drive</td> </tr> <tr> <td>VDD</td> <td>VDD</td> <td>Static Drive (also set to 1/1 Bias)</td> </tr> </tbody> </table>	DUTY1	DUTY0	Duty Drive	VSS	VSS	1/4 Duty Drive	VSS	VDD	1/3 Duty Drive	VDD	VSS	1/2 Duty Drive	VDD	VDD	Static Drive (also set to 1/1 Bias)	VDD / VSS													
DUTY1	DUTY0	Duty Drive																													
VSS	VSS	1/4 Duty Drive																													
VSS	VDD	1/3 Duty Drive																													
VDD	VSS	1/2 Duty Drive																													
VDD	VDD	Static Drive (also set to 1/1 Bias)																													
DUTY1	I		VDD / VSS																												
BIAS	I	LCD Bias select VDD: 1/2 Bias, VSS: 1/3 Bias (Static Drive: don't care)	VDD / VSS																												
GLSCHKO	O	Output for glass breaking detection Connect to GLSCHKI for glass breaking detection.	OPEN																												
GLSCHKI	I	Input for glass breaking detection Connect to GLSCHKO for glass breaking detection.	VSS																												
ERROUT	O	Output data of error detection VDD: Abnormal status, VSS: Normal status	OPEN																												
DUMMY0 to DUMMY3	-	Can be used for the contact resistance measurement.	OPEN																												
DUMMY	-	Open	OPEN																												
TR	I	POR enable setting ^(Note 1) VDD: POR disable, VSS: POR enable	VSS																												
T0,T1,T2	I	Test input (ROHM use only) Must be connected to VSS.	VSS																												
SEG0 to SEG79	O	Segment output for LCD driving	OPEN																												
COMA0 to COMA3	O	Common output for LCD driving	OPEN																												
COMB0 to COMB3	O	Common output for LCD driving	OPEN																												
COMC0 to COMC3	O	Common output for LCD driving	OPEN																												

(Note 1) This function is guaranteed by design, not tested in production process. Software Reset is necessary to initialize IC in case of TR = VDD.

Recommended ITO Layout

Function	Setting
POR	USE TR = VSS
Error Detection	YES (Glass Breaking Detection, Contact Resistance Check)
Multi-chip Mode	NO
Duty Drive	1/4 Duty Drive (DUTY0, DUTY1) = (VSS, VSS)
Bias Setting	1/3 Bias BIAS = VSS
I/F	2-wire Serial Interface IFSEL = VSS
Clock Mode	Internal Clock Mode EXTCLK = VSS
Master/Slave	Master (MS1, MS2) = (VSS, VSS)
Inhibit Function	NO INH = VDD

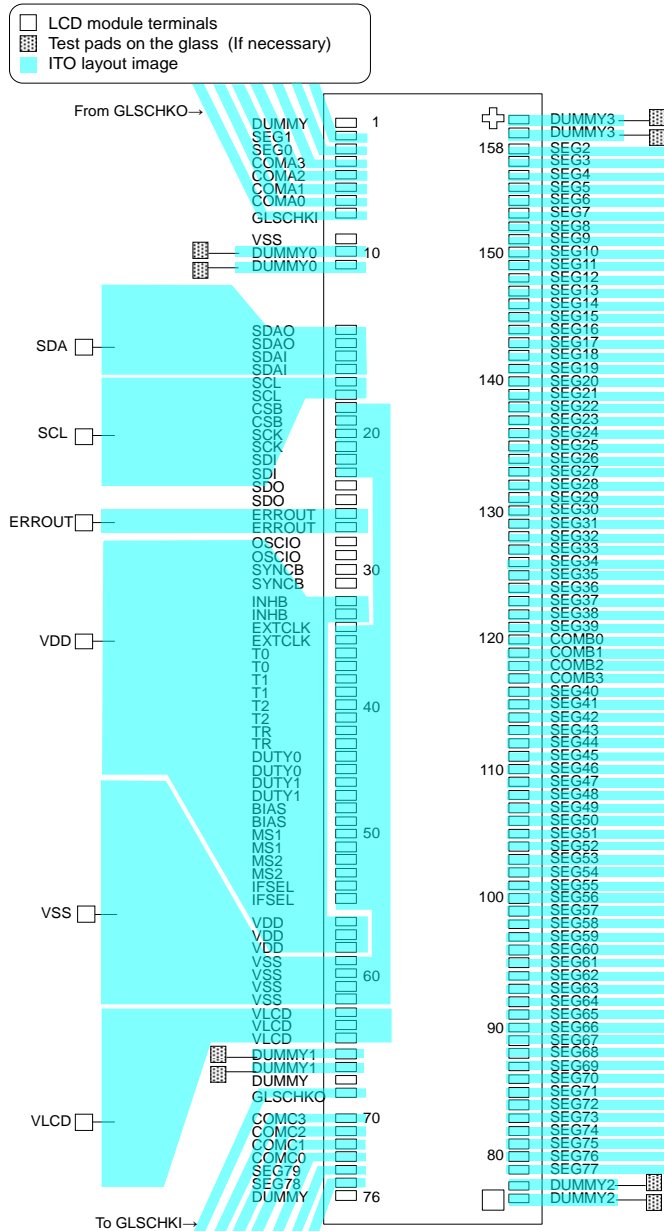

Recommended ITO Layout – continued

Function	Setting
POR	Not USE TR = VDD
Error Detection	NO
Multi-chip Mode	YES
Duty Drive	Static Drive (DUTY0, DUTY1) = (VDD, VDD)
Bias Setting	Static Drive BIAS = VSS
I/F	3-wire Serial Interface IFSEL = VDD
Clock Mode	Internal Clock Mode EXTCLK = VSS
Master/Slave	Slave1 (MS1, MS2) = (VDD, VSS)
Inhibit Function	YES INH = MCU control

LCD module terminals
 ITO layout image

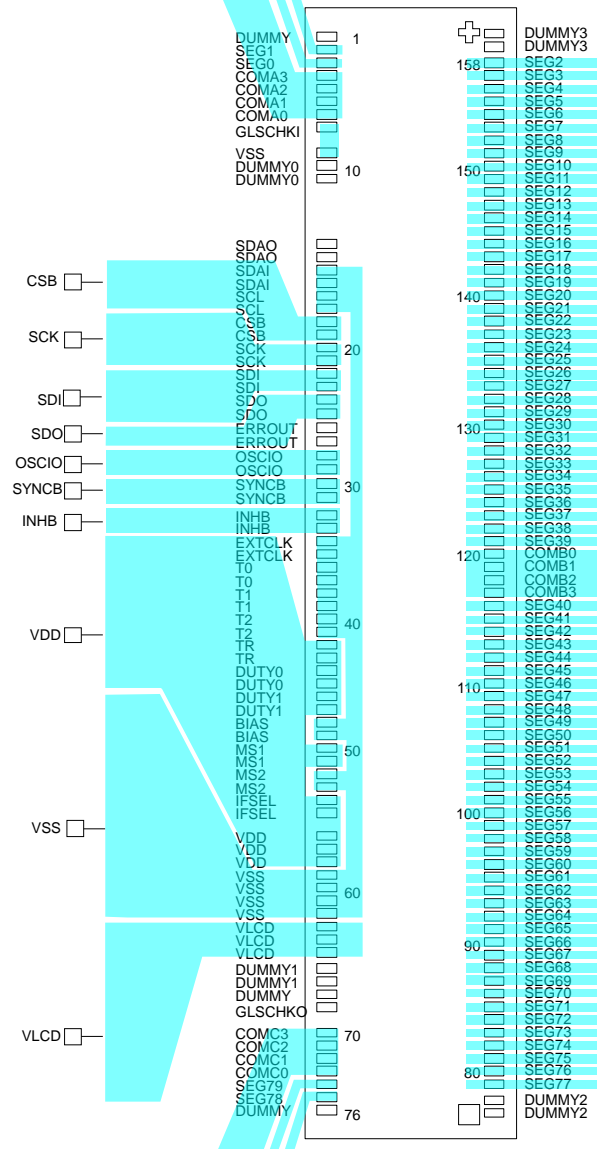

Recommended ITO Layout – continued

Terminal Resistance

PAD No.	Terminal Name	Maximum Resistance
12, 13	SDAO	1,500 Ω
14, 15	SDAI	1,500 Ω
16, 17	SCL	1,500 Ω
18, 19	CSB	1,500 Ω
20, 21	SCK	1,500 Ω
22, 23	SDI	1,500 Ω
24, 25	SDO	1,500 Ω
26, 27	ERROUT	1,500 Ω
28, 29	OSCIO	1,500 Ω
30, 31	SYNCB	1,500 Ω
32, 33	INH B	1,500 Ω
56 to 58	VDD	400 Ω
59 to 62	VSS	400 Ω
63 to 65	VLCD	400 Ω

Refer to [Glass Breaking Detection](#) for GLSCHKI and GLSCHKO terminal resistance

PAD Arrangement

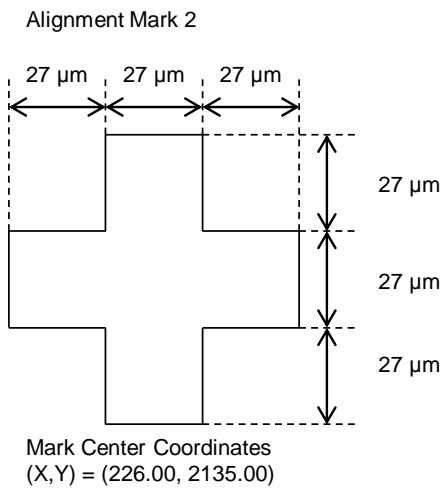
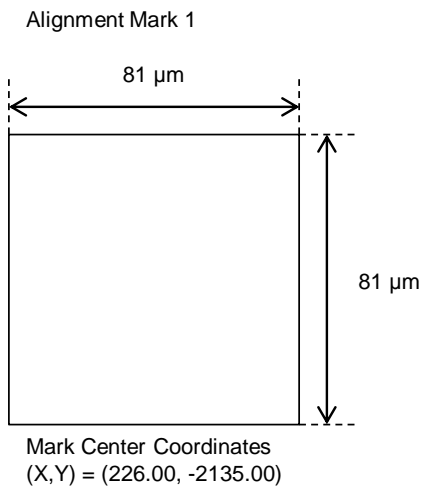
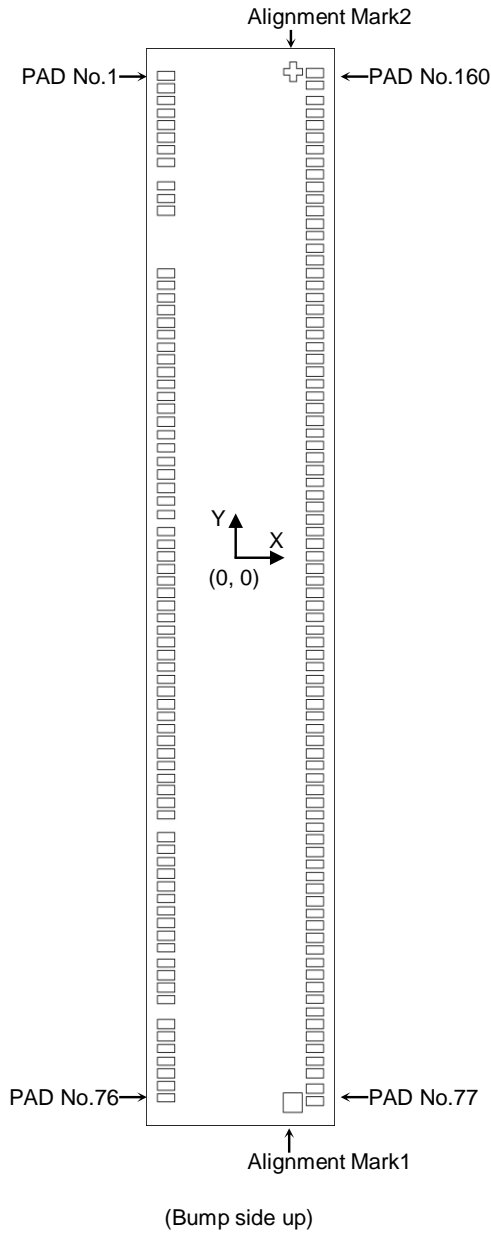

The origin of X/Y coordinates is the center of the chip with bump side up.

Dimension

Table 1. Dimension (Completion Size)

Mark		Topic	Specification Limit
Chip Size X		Chip Size : X Direction	785 ± 40 μm
Chip Size Y		Chip Size : Y Direction	4,435 ± 40 μm
Chip Thickness		Chip Thickness	300 ± 20 μm
PAD	A (PAD1 to PAD160)	Bump Size : X Direction	75.0 ± 3.0 μm
	B (PAD1 to PAD160)	Bump Size : Y Direction	36.0 ± 3.0 μm
	C (PAD1 to PAD160)	Average of Bump Height	15.0 ± 3.0 μm

Table 2. Bump Specs and Dimensions

Topic	Specification Limit
Bump Structure	Straight Bump
Bump Co-planarity on Chip	3.0 μm or less
Bump Hardness (Microvicker's Meter)	50 HV ± 20 HV
Bump Strength	7.35 mg/μm ² or more

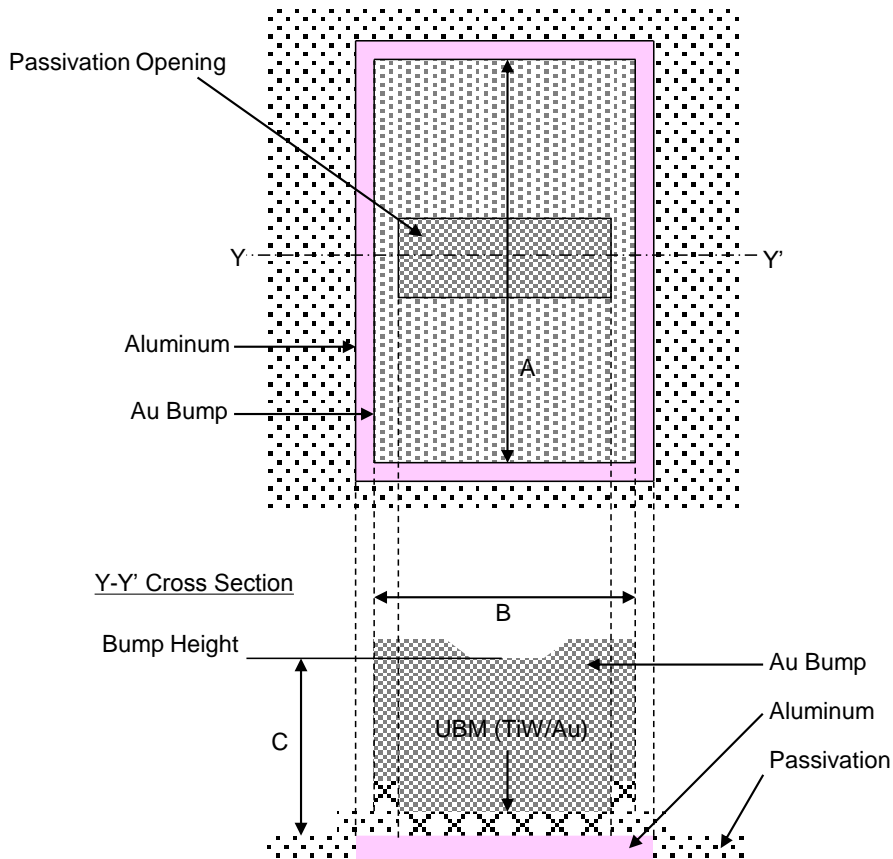

Figure 1. PAD / Bump Information

PAD Coordinates

Unit: μm

PAD No	Terminal Name	Bump Center		Bump Size	
		X	Y	X	Y
1	DUMMY	-320.50	2116.50	75	36
2	SEG1	-320.50	2065.50	75	36
3	SEG0	-320.50	2014.50	75	36
4	COMA3	-320.50	1963.50	75	36
5	COMA2	-320.50	1912.50	75	36
6	COMA1	-320.50	1861.50	75	36
7	COMA0	-320.50	1810.50	75	36
8	GLSCHKI	-320.50	1759.50	75	36
9	VSS	-320.50	1659.50	75	36
10	DUMMY0	-320.50	1608.50	75	36
11	DUMMY0	-320.50	1557.50	75	36
12	SDAO	-320.50	1298.80	75	36
13	SDAO	-320.50	1247.80	75	36
14	SDAI	-320.50	1196.80	75	36
15	SDAI	-320.50	1145.80	75	36
16	SCL	-320.50	1094.80	75	36
17	SCL	-320.50	1043.80	75	36
18	CSB	-320.50	992.80	75	36
19	CSB	-320.50	941.80	75	36
20	SCK	-320.50	890.80	75	36
21	SCK	-320.50	839.80	75	36
22	SDI	-320.50	788.80	75	36
23	SDI	-320.50	737.80	75	36
24	SDO	-320.50	685.05	75	36
25	SDO	-320.50	630.05	75	36
26	ERR0UT	-320.50	575.05	75	36
27	ERR0UT	-320.50	520.05	75	36
28	OSCIO	-320.50	465.05	75	36
29	OSCIO	-320.50	410.05	75	36
30	SYNCB	-320.50	355.05	75	36
31	SYNCB	-320.50	300.05	75	36
32	INH B	-320.50	228.85	75	36
33	INH B	-320.50	177.85	75	36
34	EXTCLK	-320.50	126.85	75	36
35	EXTCLK	-320.50	75.85	75	36
36	T0	-320.50	24.85	75	36
37	T0	-320.50	-26.15	75	36
38	T1	-320.50	-77.15	75	36
39	T1	-320.50	-128.15	75	36
40	T2	-320.50	-179.15	75	36
41	T2	-320.50	-230.15	75	36
42	TR	-320.50	-281.15	75	36
43	TR	-320.50	-332.15	75	36
44	DUTY0	-320.50	-383.15	75	36
45	DUTY0	-320.50	-434.15	75	36
46	DUTY1	-320.50	-485.15	75	36
47	DUTY1	-320.50	-536.15	75	36
48	BIAS	-320.50	-587.15	75	36
49	BIAS	-320.50	-638.15	75	36
50	MS1	-320.50	-689.15	75	36
51	MS1	-320.50	-740.15	75	36
52	MS2	-320.50	-791.15	75	36
53	MS2	-320.50	-842.15	75	36
54	IFSEL	-320.50	-893.15	75	36
55	IFSEL	-320.50	-944.15	75	36
56	VDD	-320.50	-1035.55	75	36
57	VDD	-320.50	-1086.55	75	36
58	VDD	-320.50	-1137.55	75	36
59	VSS	-320.50	-1188.55	75	36
60	VSS	-320.50	-1239.55	75	36

PAD No	Terminal Name	Bump Center		Bump Size	
		X	Y	X	Y
61	VSS	-320.50	-1290.55	75	36
62	VSS	-320.50	-1341.55	75	36
63	VLCD	-320.50	-1392.55	75	36
64	VLCD	-320.50	-1443.55	75	36
65	VLCD	-320.50	-1494.55	75	36
66	DUMMY1	-320.50	-1557.50	75	36
67	DUMMY1	-320.50	-1608.50	75	36
68	DUMMY	-320.50	-1659.50	75	36
69	GLSCHKO	-320.50	-1710.50	75	36
70	COMC3	-320.50	-1810.50	75	36
71	COMC2	-320.50	-1861.50	75	36
72	COMC1	-320.50	-1912.50	75	36
73	COMC0	-320.50	-1963.50	75	36
74	SEG79	-320.50	-2014.50	75	36
75	SEG78	-320.50	-2065.50	75	36
76	DUMMY	-320.50	-2116.50	75	36
77	DUMMY2	320.50	-2128.60	75	36
78	DUMMY2	320.50	-2077.60	75	36
79	SEG77	320.50	-2014.50	75	36
80	SEG76	320.50	-1963.50	75	36
81	SEG75	320.50	-1912.50	75	36
82	SEG74	320.50	-1861.50	75	36
83	SEG73	320.50	-1810.50	75	36
84	SEG72	320.50	-1759.50	75	36
85	SEG71	320.50	-1708.50	75	36
86	SEG70	320.50	-1657.50	75	36
87	SEG69	320.50	-1606.50	75	36
88	SEG68	320.50	-1555.50	75	36
89	SEG67	320.50	-1504.50	75	36
90	SEG66	320.50	-1453.50	75	36
91	SEG65	320.50	-1402.50	75	36
92	SEG64	320.50	-1351.50	75	36
93	SEG63	320.50	-1300.50	75	36
94	SEG62	320.50	-1249.50	75	36
95	SEG61	320.50	-1198.50	75	36
96	SEG60	320.50	-1147.50	75	36
97	SEG59	320.50	-1096.50	75	36
98	SEG58	320.50	-1045.50	75	36
99	SEG57	320.50	-994.50	75	36
100	SEG56	320.50	-943.50	75	36
101	SEG55	320.50	-892.50	75	36
102	SEG54	320.50	-841.50	75	36
103	SEG53	320.50	-790.50	75	36
104	SEG52	320.50	-739.50	75	36
105	SEG51	320.50	-688.50	75	36
106	SEG50	320.50	-637.50	75	36
107	SEG49	320.50	-586.50	75	36
108	SEG48	320.50	-535.50	75	36
109	SEG47	320.50	-484.50	75	36
110	SEG46	320.50	-433.50	75	36
111	SEG45	320.50	-382.50	75	36
112	SEG44	320.50	-331.50	75	36
113	SEG43	320.50	-280.50	75	36
114	SEG42	320.50	-229.50	75	36
115	SEG41	320.50	-178.50	75	36
116	SEG40	320.50	-127.50	75	36
117	COMB3	320.50	-76.50	75	36
118	COMB2	320.50	-25.50	75	36
119	COMB1	320.50	25.50	75	36
120	COMB0	320.50	76.50	75	36

Refer to [PAD Arrangement](#) for the definition of X/Y coordinates.

PAD Coordinates – continued

Unit μm

PAD No	Terminal Name	Bump Center		Bump Size	
		X	Y	X	Y
121	SEG39	320.50	127.50	75	36
122	SEG38	320.50	178.50	75	36
123	SEG37	320.50	229.50	75	36
124	SEG36	320.50	280.50	75	36
125	SEG35	320.50	331.50	75	36
126	SEG34	320.50	382.50	75	36
127	SEG33	320.50	433.50	75	36
128	SEG32	320.50	484.50	75	36
129	SEG31	320.50	535.50	75	36
130	SEG30	320.50	586.50	75	36
131	SEG29	320.50	637.50	75	36
132	SEG28	320.50	688.50	75	36
133	SEG27	320.50	739.50	75	36
134	SEG26	320.50	790.50	75	36
135	SEG25	320.50	841.50	75	36
136	SEG24	320.50	892.50	75	36
137	SEG23	320.50	943.50	75	36
138	SEG22	320.50	994.50	75	36
139	SEG21	320.50	1045.50	75	36
140	SEG20	320.50	1096.50	75	36
141	SEG19	320.50	1147.50	75	36
142	SEG18	320.50	1198.50	75	36
143	SEG17	320.50	1249.50	75	36
144	SEG16	320.50	1300.50	75	36
145	SEG15	320.50	1351.50	75	36
146	SEG14	320.50	1402.50	75	36
147	SEG13	320.50	1453.50	75	36
148	SEG12	320.50	1504.50	75	36
149	SEG11	320.50	1555.50	75	36
150	SEG10	320.50	1606.50	75	36
151	SEG9	320.50	1657.50	75	36
152	SEG8	320.50	1708.50	75	36
153	SEG7	320.50	1759.50	75	36
154	SEG6	320.50	1810.50	75	36
155	SEG5	320.50	1861.50	75	36
156	SEG4	320.50	1912.50	75	36
157	SEG3	320.50	1963.50	75	36
158	SEG2	320.50	2014.50	75	36
159	DUMMY3	320.50	2077.60	75	36
160	DUMMY3	320.50	2128.60	75	36

Refer to [PAD Arrangement](#) for the definition of X/Y coordinates.

Absolute Maximum Ratings (VSS = 0V)

Parameter	Symbol	Ratings			Unit	Remarks
		Min	Typ	Max		
Maximum Voltage1	VDD	-0.5	-	+7.0	V	Power Supply
Supply Current1	I _{VDD}	-5	-	+5	mA	For VDD
Maximum Voltage2	VLCD	-0.5	-	+7.0	V	LCD Drive Voltage
Supply Current2	I _{VLCD}	-5	-	+5	mA	For VLCD
Input Voltage Range	V _{IN}	-0.5	-	+7.0	V	-
Output Voltage Range	V _{OUT}	-0.5	-	+7.0	V	-
Human Body Model (HBM) (Note 1), (Note 2)	V _{ESD}	-	±2,000	-	V	-
Latch-up Current ^{(Note 1), (Note 3)}	I _{LU}	-	±100	-	mA	-
Maximum Junction Temperature	T _{jmax}	-55	-	+125	°C	-
Storage Temperature Range	T _{stg}	-55	-	+125	°C	-

(Note 1) Not 100 % tested. There is data when LSI was put on a temporary package. Use as a reference data.

(Note 2) Testing standards: JESD22-A114E

(Note 3) Testing standards: JESD78

Caution : Operating the IC over the absolute maximum ratings may damage the IC. The damage can either be a short circuit between pins or an open circuit between pins and the internal circuitry. Therefore, it is important to consider circuit protection measures, such as adding a fuse, in case the IC is operated over the absolute maximum ratings.

Recommended Operating Conditions

Parameter	Symbol	Ratings			Unit	Remarks
		Min	Typ	Max		
Operational Temperature	Topr	-40	-	+105	°C	-
Power Supply Voltage 1	VDD	2.7	-	6.0	V	Power Supply
Power Supply Voltage 2	VLCD	2.7	-	6.0	V	LCD Drive Voltage

Electrical Characteristics

DC Characteristics

(Unless otherwise specified, Ta = -40 °C to +105 °C, VDD / VLCD = 2.7 V to 6.0 V, VSS = 0 V)

Parameter	Symbol	Limits			Unit	Condition
		Min	Typ	Max		
"H" Level Input Voltage1	V _{IH1}	0.7VDD	-	VDD	V	SCL, SDAI
"L" Level Input Voltage1	V _{IL1}	VSS	-	0.3VDD	V	
"H" Level Input Voltage2	V _{IH2}	0.8VDD	-	VDD	V	CSB, SCK, SDI, INHB, OSCIO ^(Note)
"L" Level Input Voltage2	V _{IL2}	0	-	0.2VDD	V	
"H" Level Input Current	I _{IH}	-	-	1	μA	SCL, SDAI, CSB, SCK, SDI, INHB, OSCIO, TR, MS1, MS2, EXTCLK, IFSEL, DUTY0, DUTY1, BIAS, GLSCHKI
"L" Level Input Current	I _{IL}	-1	-	-	μA	
"H" Level Output Voltage1	V _{OH1}	VDD-0.9	-	VDD	V	SDO, ERRROUT (I _{LOAD} = -1 mA)
"L" Level Output Voltage1	V _{OL1}	VSS	-	0.9	V	SDO, ERRROUT (I _{LOAD} = +1 mA)
"L" Level Output Voltage2	V _{OL2}	VSS	-	0.4	V	SDAO (I _{LOAD} = +3 mA)
LCD Driver On Resistance	SEG	R _{ON1}	-	3	-	kΩ I _{LOAD} = ±10 μA
	COM	R _{ON2}	-	3	-	
Standby Current		I _{VDD1}	-	-	5.0	μA Display Off (DISPOFF), Oscillation stop
		I _{VLCD1}	-	-	5.0	
Operating Current		I _{VDD2}	-	0.5	20.0	μA VDD = 5.0 V, VLCD = 5.0 V, Ta = +25 °C, 1/4 Duty Drive, 1/3 Bias Frame Inversion FR = 155.3 Hz setting (External Clock = 3.42 kHz) All outputs are open
		I _{VLCD2}	-	6.5	30.0	

(Note) For External Clock Mode and slave mode.

[Reference Data]

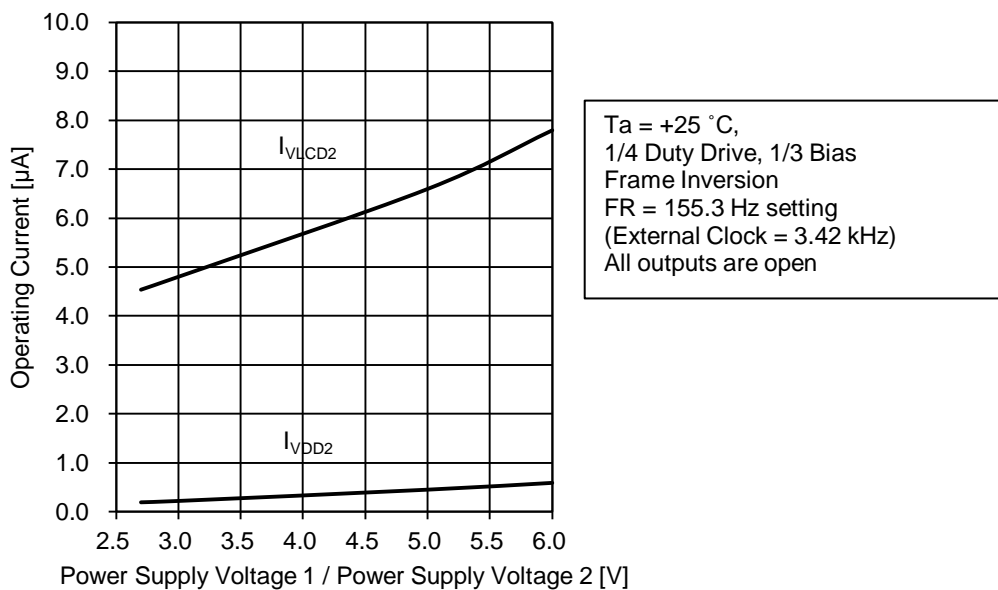

Figure 2. Operating Current vs Power Supply Voltage

Electrical Characteristics – continued

Oscillation Characteristics

(Unless otherwise specified, Ta = -40 °C to +105 °C, VDD / VLCD = 2.7 V to 6.0 V, VSS = 0 V)

Parameter	Symbol	Limits			Unit	Condition
		Min	Typ	Max		
Frame Frequency 1	f _{CLK1}	108.7	155.3	201.9	Hz	MODESET3 P0 = "0", FRSET(P2 to P0) = "110" (155.3 Hz setting) VDD = 2.7 V to 6.0 V, Ta = -40 °C to +105 °C
Frame Frequency 2	f _{CLK2}	139.8	155.3	170.8	Hz	MODESET3 P0 = "0", FRSET(P2 to P0) = "110" (155.3 Hz setting) VDD = 5.0 V, Ta = -40 °C to +105 °C
External Clock Rise Time	tr _{CLK}	-	-	0.3	µs	External Clock Mode
External Clock Fall Time	tf _{CLK}	-	-	0.3	µs	
External Clock Frequency	f _{CLK3}	800	-	12,000	Hz	
External Clock Duty	t _{DTY}	30	50	70	%	
Frame Frequency Range in External Clock Mode	f _{FRAME}	33	-	500	Hz	

Keep Frame Frequency range from 33 Hz to 500 Hz in case of External Clock Mode, also keep external clock frequency range from 800 Hz to 12,000 Hz.

The calculation formula is shown in [4. Frame Rate Set \(FRSET\)](#).

[Reference Data]

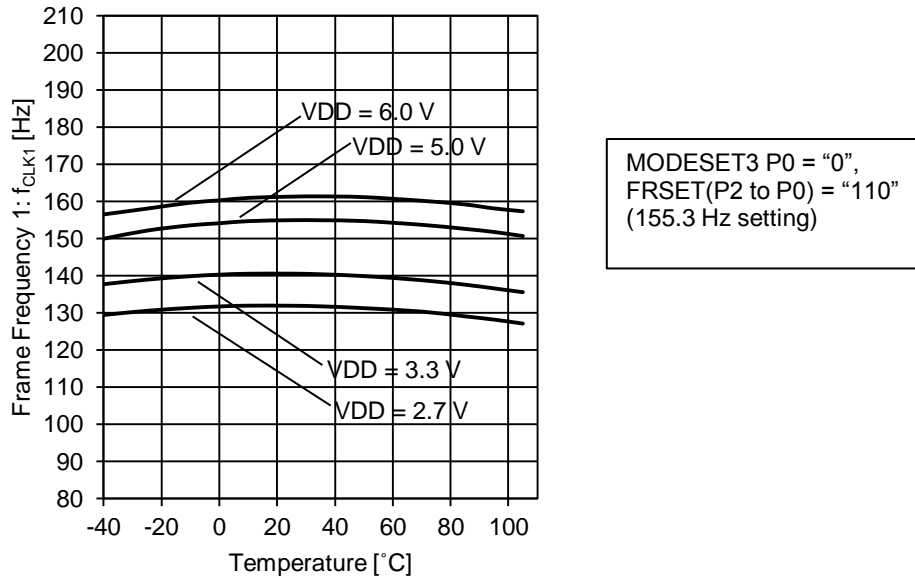

Figure 3. Frame Frequency vs Temperature

Electrical Characteristics – continued

2-wire Serial Interface Characteristics

(Unless otherwise specified, Ta = -40 °C to +105 °C, VDD = 2.7 V to 6.0 V, VSS = 0 V)

Parameter	Symbol	Limits			Unit	Condition
		Min	Typ	Max		
Input Rise Time	tr	-	-	0.3	μs	-
Input Fall Time	tf	-	-	0.3	μs	-
SCL Cycle Time	t _{CYC}	2.5	-	-	μs	-
“H” Level SCL Pulse Width	t _{SHW}	0.6	-	-	μs	-
“L” Level SCL Pulse Width	t _{SLW}	1.3	-	-	μs	-
SDA Setup Time	t _{SDS}	0.1	-	-	μs	-
SDA Hold Time	t _{SDH}	0.1	-	-	μs	-
Bus Free Time	t _{BUF}	1.3	-	-	μs	-
START Condition Hold Time	t _{HD;STA}	0.6	-	-	μs	-
START Condition Setup Time	t _{SU;STA}	0.6	-	-	μs	-
STOP Condition Setup Time	t _{SU;STO}	0.6	-	-	μs	-

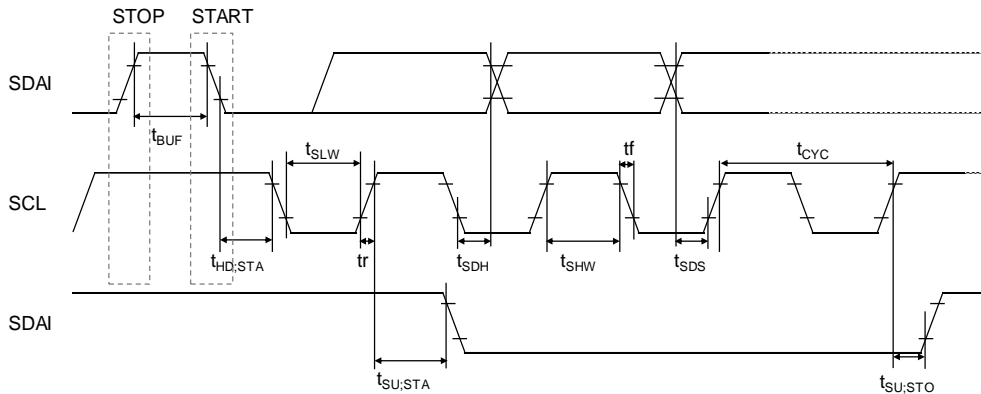

Figure 4. Interface Timing of 2-wire Serial Interface

Since SDAO is an open-drain output, Read access time depends on ITO resistance R_{ITO} , Pull-up resistance R_{PU} and load capacitance C_L .

R_{ITO} : ITO resistance on the LCD glass. (Any component is not necessary to be attached.)

R_{PU} : Pull-up resistance on PCB. $1\text{ k}\Omega \leq R_{PU} \leq 10\text{ k}\Omega$ is recommended.

C_L : A parasitic capacitance to VSS in an application circuit. (Any component is not necessary to be attached.)

R_{PU} should be determined with consideration of V_{IL} in MCU side.

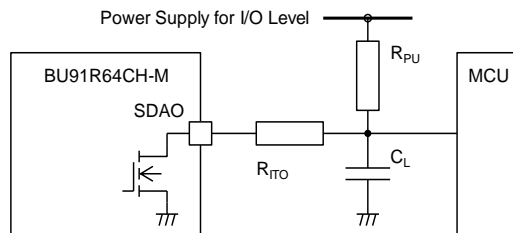

Electrical Characteristics – continued

3-wire Serial Interface Characteristics

(Unless otherwise specified, Ta = -40 °C to +105 °C, VDD = 2.7 V to 6.0 V, VSS = 0 V)

Parameter	Symbol	Limits			Unit	Condition
		Min	Typ	Max		
Input Rise Time	tr	-	-	80	ns	-
Input Fall Time	tf	-	-	80	ns	-
SCK Cycle Time	tSCYC	400	-	-	ns	-
“H” Level SCK Pulse Width (Write)	tSHWW	120	-	-	ns	Write Access
“H” Level SCK Pulse Width (Read)	tSHWR	200	-	-	ns	Read Access
“L” Level SCK Pulse Width (Write)	tSLWW	120	-	-	ns	Write Access
“L” Level SCK Pulse Width (Read)	tSLWR	1.6	-	-	μs	Read Access
SDI Setup Time	tSDS	120	-	-	ns	-
SDI Hold Time	tSDH	120	-	-	ns	-
CSB Setup Time	tCSS	120	-	-	ns	-
CSB Hold Time	tCSH	120	-	-	ns	-
“H” CSB Pulse Width	tCHW	120	-	-	ns	-
SDO Output Delay Time	tDC	-	-	1.5	μs	R _{ITO} = 1.0 kΩ, C _L = 10 pF
SDO Rise Time	tDR	-	-	1.5	μs	R _{ITO} = 1.0 kΩ, C _L = 10 pF

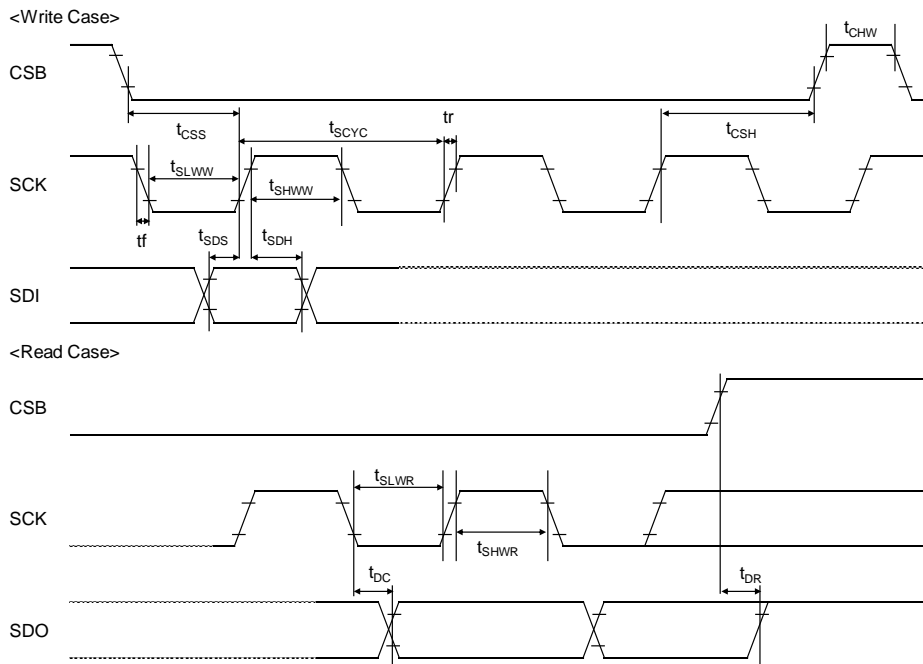
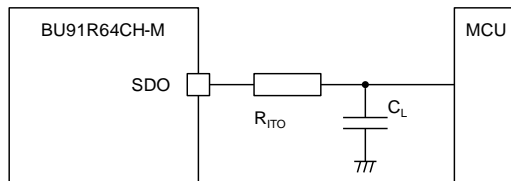

Figure 5. Interface Timing of 3-wire Serial Interface

“t_{DC}” and “t_{DR}” depend on ITO resistance R_{ITO} and load capacitance C_L.

R_{ITO}: ITO resistance on the LCD glass. (Any component is not necessary to be attached.)

C_L: A parasitic capacitance to VSS in an application circuit. (Any component is not necessary to be attached.)



I/O Equivalence Circuit

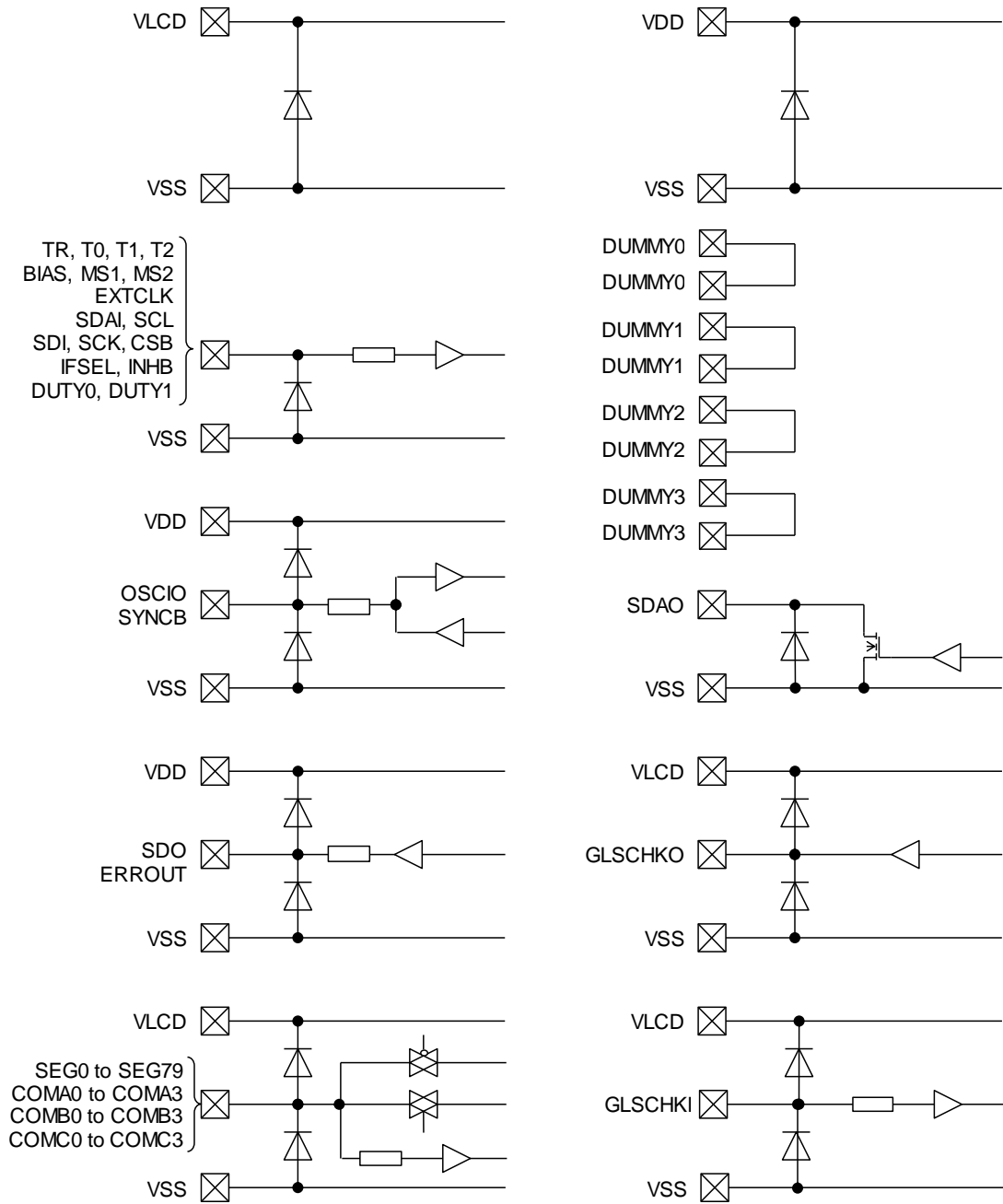

MCU Interface

BU91R64CH-M supports two MCU Interfaces. In IFSEL = VSS, 2-wire Serial Interface (hereinafter referred to as “2-wire”) is available. And in IFSEL = VDD, 3-wire Serial Interface (hereinafter referred to as “3-SPI”) is available.

START and STOP Condition (2-wire)

In IFSEL = VSS, BU91R64CH-M is controlled by 2-wire signals (SDAI, SCL).

It is necessary to generate “START Condition” and “STOP Condition” when sending command or Display Data.

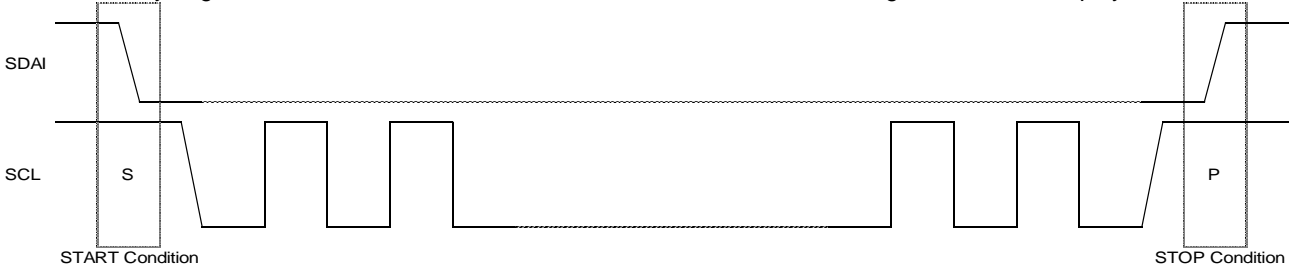

Figure 6. 2-wire Command / Data Transfer Format

Acknowledge (ACK) (2-wire)

Data format is comprised of 8-bit data to SDAI. And an acknowledge bit is returned from SDAO terminal after the 8-bit data is sent. SDAO is also used in Display Data read-back and Command Registers read-back. The serial data input line (SDAI) and the serial data output line (SDAO) are separated in PAD assignment, but both terminals can be connected together to facilitate a single line SDA.

After the transfer of 8-bit data (Slave Address, Control Byte, Command, Display Data), release the SDA line at the falling edge of the eighth clock. The SDA line is then pulled low until the falling edge of the ninth clock SCL. (Output cannot be pulled high because of open-drain NMOS output structure). If the acknowledge function is not required, keep SDA line at low level from the eighth falling edge to the ninth falling edge of SCL.

Not acknowledged bit (NACK) will be returned in following cases.

- (1) Incorrect Slave Address
- (2) Different Sub Address (in receiving Display Data, CNTSET and COMSET commands)

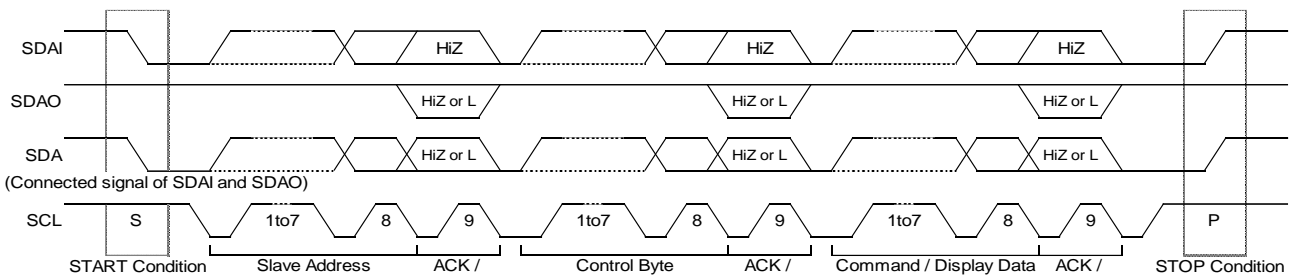

Figure 7. Acknowledge Timing

When Slave Address cannot be recognized correctly in the first data transfer, NACK will be generated and next transfer will be invalid. Even in the invalid status, BU91R64CH-M will return to valid status by receiving “START Condition” again.

Consider MCU Interface Characteristics such as Input rise time and Setup / Hold time when transferring command and data. Refer to [2-wire Serial Interface Characteristics](#).

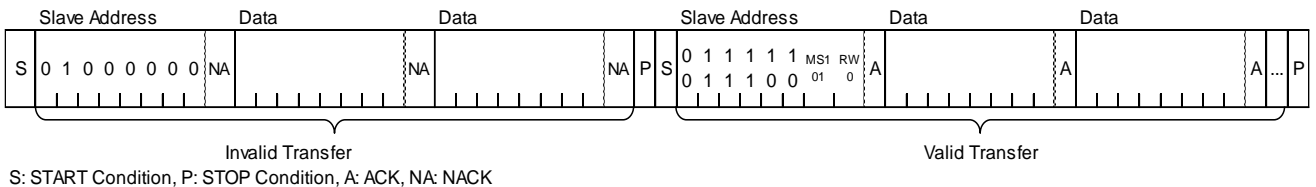

Figure 8. Wrong Slave Address Case

MCU Interface - continued

Command / Display Data Transfer Method (2-wire)

Issue Slave Address after generating "START Condition". The first byte after Slave Address must be Control Byte. The Control Byte consists of 8bits: CO, RS, and 6 undefined bits. The first bit is CO: continuous data bytes / single data byte selector and the second bit is RS: Command / Display Data selector and the others are undefined bits.

CO	Function
0	Continuous data bytes available after the Control Byte.
1	Only single data byte available after the Control Byte. After the data byte, Control Byte can be accepted again.

RS	Function
0	Command is received after the Control Byte.
1	Display Data is received after the Control Byte. Continuous Display Data is available regardless of CO value.

The following procedure shows how to transfer Command and Display Data.

- (1) Generate "START Condition".
- (2) Issue Slave Address. *(Note 1)*
- (3) Transfer Control Byte.
- (4) Transfer Command and Display Data.
- (5) Generate "STOP Condition".

(Note 1) Slave Address is specified by MS1 setting. (2-wire mode only)

MS1	Slave Address [7:1]
0	0111110 / 0111000
1	0111111 / 0111001

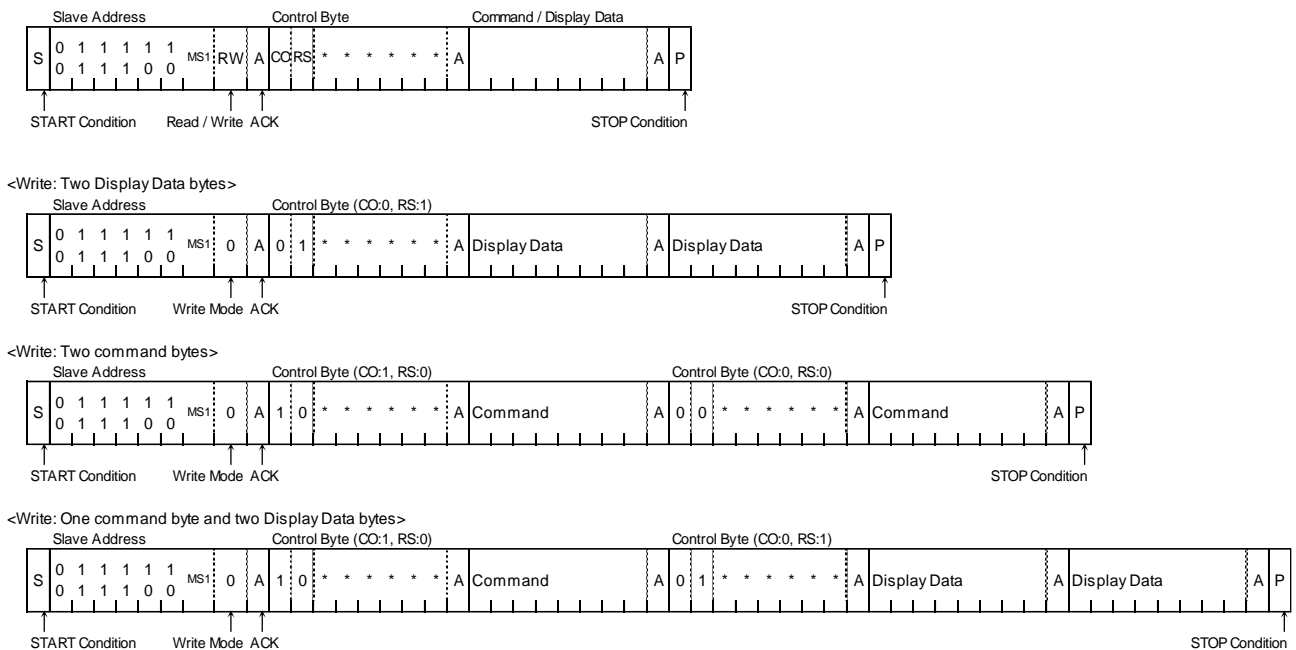
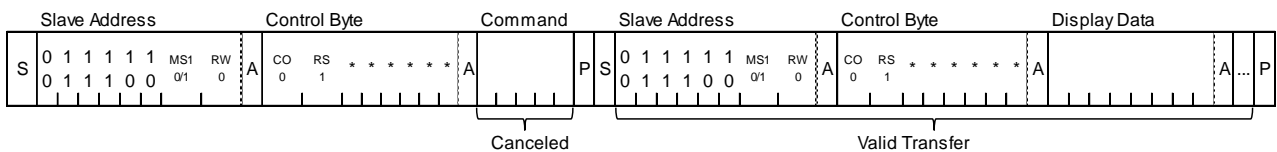

Figure 9. 2-wire Interface Protocol

BU91R64CH-M cannot accept Control Byte / Command once it enters into continuous data transfer state. "STOP Condition" and "START Condition" are necessary in order to accept Command again. If "START Condition" or "STOP Condition" is received during Command / Display Data transfer, the byte in transferring will be cancelled.

Then if Slave Address is received after the "START Condition", BU91R64CH-M enters into Control Byte transfer state.



S: START Condition, P: STOP Condition, A: ACK, NA: NACK

Figure 10. Case of Exiting Data Transfer State in 2-wire

MCU Interface - continued

Display Data Transfer Method (2-wire)

For Display Data write, set R/W bit in Slave Address byte to "0" (Write Mode) and Bit6 in Control Byte to "1". BU91R64CH-M has a Display Data RAM (DDRAM) of 80 x 4 = 320-bit. SADSET and ADSET commands specify the address where the first Display Data Byte is written. The address is automatically incremented in every 4-bit data and the Display Data is written to DDRAM at the same timing. Smaller Display Data than 4-bit will be cancelled in the transfer.

Burst write into DDRAM is available by transferring data continuously. The address is returned to 00h by the auto-increment function after writing Display Data to the last address. BU91R64CH-M escapes from the burst mode by STOP Condition.

Ex. in 1/4 Duty Drive, the address is returned to 00h (for SEG0) after writing data into address = 4Fh (for SEG79). In case of Static Drive Mode, maximum address is 13h (for SEG76 to SEG79).

The relationships between input Display Data, DDRAM address map and SEG output are as follows.

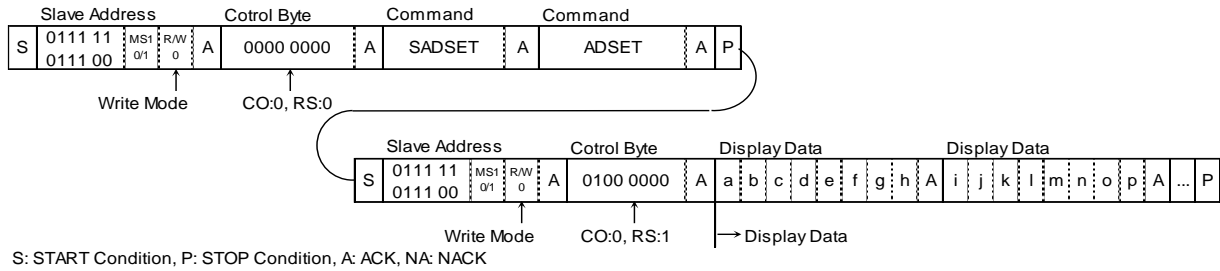

Figure 11. Display Data Transfer in 2-wire

1/4 Duty

ADSET	00h	01h	02h	03h	04h	05h	06h	07h	08h	09h	0Ah	0Bh	0Ch	0Dh	0Eh	0Fh	...	40h	41h	42h	43h	44h	45h	46h	47h	48h	49h	4Ah	4Bh	4Ch	4Dh	4Eh	4Fh		
D7,D3	a	e	i	m														...																	
D6,D2	b	f	j	n														...																	
D5,D1	c	g	k	o														...																	
D4,D0	d	h	l	p														...																	
	SEG0	SEG1	SEG2	SEG3	SEG4	SEG5	SEG6	SEG7	SEG8	SEG9	SEG10	SEG11	SEG12	SEG13	SEG14	SEG15	...	SEG64	SEG65	SEG66	SEG67	SEG68	SEG69	SEG70	SEG71	SEG72	SEG73	SEG74	SEG75	SEG76	SEG77	SEG78	SEG79		

1/3 Duty

ADSET	00h	01h	02h	03h	04h	05h	06h	07h	08h	09h	0Ah	0Bh	0Ch	0Dh	0Eh	0Fh	...	40h	41h	42h	43h	44h	45h	46h	47h	48h	49h	4Ah	4Bh	4Ch	4Dh	4Eh	4Fh		
D7,D3	a	e	i	m														...																	
D6,D2	b	f	j	n														...																	
D5,D1	c	g	k	o														...																	
	SEG0	SEG1	SEG2	SEG3	SEG4	SEG5	SEG6	SEG7	SEG8	SEG9	SEG10	SEG11	SEG12	SEG13	SEG14	SEG15	...	SEG64	SEG65	SEG66	SEG67	SEG68	SEG69	SEG70	SEG71	SEG72	SEG73	SEG74	SEG75	SEG76	SEG77	SEG78	SEG79		

1/2 Duty

ADSET	00h	01h	02h	03h	04h	05h	06h	07h	08h	09h	0Ah	0Bh	0Ch	0Dh	0Eh	0Fh	...	40h	41h	42h	43h	44h	45h	46h	47h	48h	49h	4Ah	4Bh	4Ch	4Dh	4Eh	4Fh		
D7,D3	a	e	i	m														...																	
D6,D2	b	f	j	n														...																	
	SEG0	SEG1	SEG2	SEG3	SEG4	SEG5	SEG6	SEG7	SEG8	SEG9	SEG10	SEG11	SEG12	SEG13	SEG14	SEG15	...	SEG64	SEG65	SEG66	SEG67	SEG68	SEG69	SEG70	SEG71	SEG72	SEG73	SEG74	SEG75	SEG76	SEG77	SEG78	SEG79		

Area for bank blink

Static drive

ADSET	00h				01h				02h				03h				...	10h				11h				12h				13h					
D7 to D0	a	b	c	d	e	f	g	h	i	j	k	l	m	n	o	p	...																		
	SEG0	SEG1	SEG2	SEG3	SEG4	SEG5	SEG6	SEG7	SEG8	SEG9	SEG10	SEG11	SEG12	SEG13	SEG14	SEG15	...	SEG64	SEG65	SEG66	SEG67	SEG68	SEG69	SEG70	SEG71	SEG72	SEG73	SEG74	SEG75	SEG76	SEG77	SEG78	SEG79		

Area for bank blink

Figure 12. DDRAM Address Map in Write Mode

MCU Interface - continued

Display Data Read-back Method (2-wire)

For Read Mode, set RW bit in Slave Address byte to "1". In advance, Read_data bit in RDCTL must be set to "1" for reading Display Data. The Display Data values can be read during Read Mode. The sequence of the Display Data read-back is shown below.

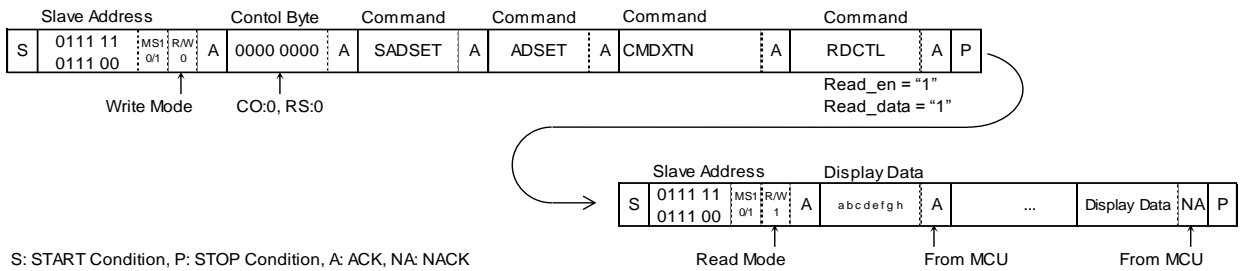

Figure 13. Display Data Read-back in 2-wire

During Read Mode, the Display Data can be read from the DDRAM through the SDAO line. The data will output synchronized with falling edge of SCL input.

SADSET and ADSET must be set first during Write Mode in advance. If DDRAM address is not specified before Display Data read, the current DDRAM address is used as the first read address. Address will be incremented automatically by +2 addresses after 8-bit data output. The Address will be set to 00h automatically after maximum address.

MCU must reply ACK to BU91R64CH-M after each 8-bit data output to keep Read Mode. If MCU replies no ACK response (NACK), BU91R64CH-M will escape Read Mode and SDAO output status will be released.

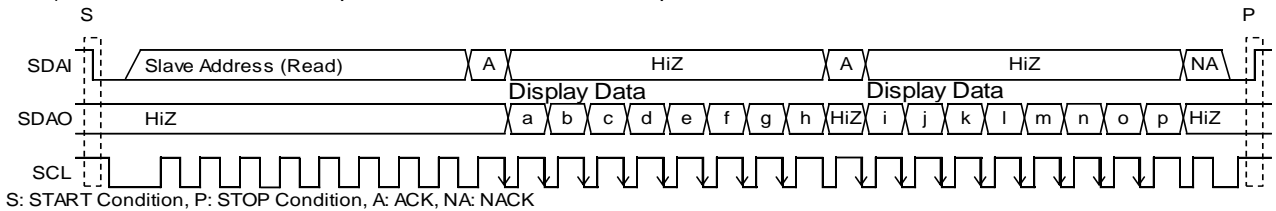

Figure 14. Bit-Assignment in Display Data Read-back in 2-wire

1/4 Duty		1/3 Duty		1/2 Duty		Static drive	
ADSET	00h-4Fh	ADSET	00h-4Fh	ADSET	00h-4Fh	ADSET	00h-4Fh
D7,D3	a e i m	a e i m	a e i m	a e i m	a e i m	a e i m	a e i m
D6,D2	b f j n	b f j n	b f j n	b f j n	b f j n	b f j n	b f j n
D5,D1	c g k o	c g k o	c g k o	c g k o	c g k o	c g k o	c g k o
D4,D0	d h l p	* * * *	* * * *	d h l p	* * * *	d h l p	* * * *
SEG0							
SEG1							
SEG2							
SEG3							
SEG4							
SEG5							
SEG6							
SEG7							
SEG8							
SEG9							
SEG10							
SEG11							
SEG12							
SEG13							
SEG14							
SEG15							
SEG64							
SEG65							
SEG66							
SEG67							
SEG68							
SEG69							
SEG70							
SEG71							
SEG72							
SEG73							
SEG74							
SEG75							
SEG76							
SEG77							
SEG78							
SEG79							

Figure 15. DDRAM Address Map in Read Mode

MCU Interface - continued

Command Registers Read-back Method (2-wire)

For Read Mode, set R/W bit in Slave Address byte to "1". In advance, Read_data bit in RDCTL must be set to "0" for reading Command Registers. The Command Registers can be read during Read Mode. The sequence of the Command Registers read-back is shown below and is similar to the Display Data read sequence.

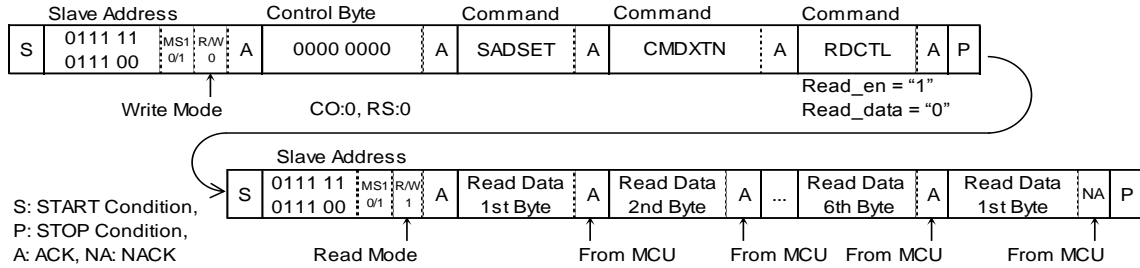

Figure 16. Command Registers Read-back Method in 2-wire

After the sixth byte data, the first byte data will be outputted again. Command Registers read-back mode can be released at NACK condition (Same as Read Display Data).

Table 3. Command Registers Map for Read-back

Byte	Bit	Read Data	Remark
1st Byte	D7	Enable for Glass Breaking Detection	MODESET2 P3
	D6	Enable for Interface Checksum Detection	MODESET2 P2
	D5	Enable for Logic Error Detection	MODESET2 P1
	D4	Enable for SEG / COM Toggle Detection	MODESET2 P0
	D3	Status of Glass Breaking Detection	1: Abnormal, 0: Normal
	D2	Status of Interface Checksum Detection	1: Abnormal, 0: Normal
	D1	Status of Logic Error Detection	1: Abnormal, 0: Normal
	D0	Status of SEG / COM Toggle Detection	1: Abnormal, 0: Normal
2nd Byte	D7	Display On	MODESET1 P3
	D6	Blink Mode	BLKCTL1 P2
	D5	2x frequency in frame Inversion	MODESET3 P1
	D4	Inversion Mode	MODESET3 P2
	D3	Higher Frequency Mode	MODESET3 P0
	D2	Frame Rate Bit2	FRSET P2
	D1	Frame Rate Bit1	FRSET P1
	D0	Frame Rate Bit0	FRSET P0
3rd Byte	D7	Blink Freq. Bit1	BLKCTL1 P1
	D6	Blink Freq. Bit0	BLKCTL1 P0
	D5	Blink Area Select	BLKCTL2 P1
	D4	EVR Bit4	COMSET P3
	D3	EVR Bit3	CNTSET P3
	D2	EVR Bit2	CNTSET P2
	D1	EVR Bit1	CNTSET P1
	D0	EVR Bit0	CNTSET P0
4th Byte	D7	IFCHKSUM Bit3	CHKSUM P3
	D6	IFCHKSUM Bit2	CHKSUM P2
	D5	IFCHKSUM Bit1	CHKSUM P1
	D4	IFCHKSUM Bit0	CHKSUM P0
	D3	0	-
	D2	COMSET Bit2	COMSET P2
	D1	COMSET Bit1	COMSET P1
	D0	COMSET Bit0	COMSET P0
5th Byte	D7	0	-
	D6	0	-
	D5	Sub Address Set Bit1	SADSET P1
	D4	Sub Address Set Bit0	SADSET P0
	D3	0	-
	D2	0	-
	D1	0	-
	D0	0	-
6th Byte	D7	0	-
	D6	Address Set Bit6	ADSET P6
	D5	Address Set Bit5	ADSET P5
	D4	Address Set Bit4	ADSET P4
	D3	Address Set Bit3	ADSET P3
	D2	Address Set Bit2	ADSET P2
	D1	Address Set Bit1	ADSET P1
	D0	Address Set Bit0	ADSET P0

MCU Interface - continued

Command / Display Data Transfer Method (3-SPI)

In IFSEL = VDD, BU91R64CH-M is controlled by 3-wire signals (CSB, SCK, and SDI). First, Interface counter is initialized with CSB = high, then CSB = low enables SDI and SCK input.

D7 to D0 follows continuously after CSB = low. Internal data is latched at the rising edge of SCK. Command is converted to 8-bit parallel data at the rising edge of the eighth SCK. Display Data is stored at the fourth and the eighth falling edge of SCK. The protocol of 3-SPI transfer is as follows.

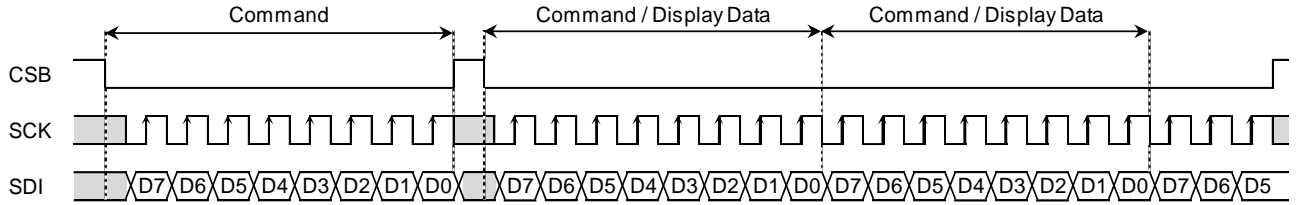

Figure 17. Command / Data Transfer in 3-SPI Command / Data Transfer in 3-SPI

Command Transfer Method (3-SPI)

After CSB changes from high to low, the first byte is always a command input. To escape Display Data transfer condition or to send command again, CSB should be set from low to high then set to low.

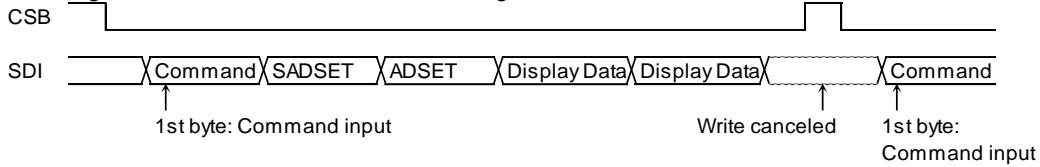

Figure 18. Escape from Data Transfer Condition in 3-SPI

Command transfer is done by 8-bit unit, so if CSB is set from low to high with less than 8-bit data transfer, command will be cancelled. It will be able to transfer command when CSB = low again.

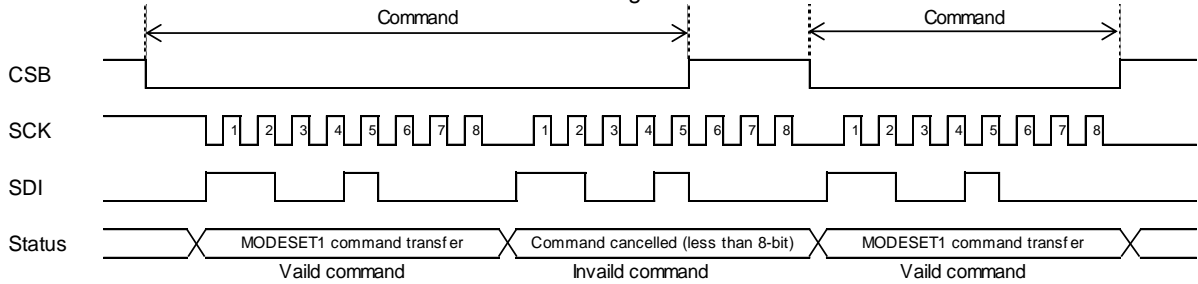

Figure 19. Case of Less Than 8-bit Data Transfer in 3-SPI

MCU Interface - continued

Display Data Transfer Method (3-SPI)

In 3-SPI, BU91R64CH-M enters to Display Data write state after receiving ADSET command. BU91R64CH-M has a Display Data RAM (DDRAM) of 80 x 4 = 320-bit. SADSET and ADSET commands specify the address where the first Display Data Byte is written. The address is automatically incremented in every 4-bit data and the Display Data is written to DDRAM at the same timing. Smaller Display Data than 4-bit will be cancelled in the transfer.

Burst write into DDRAM is available by transferring data continuously. The address is returned to 00h by the auto-increment function after writing Display Data to the last address. BU91R64CH-M escapes from the burst mode by setting CSB to high. Ex. in 1/4 Duty Drive mode, the address is returned to 00h (for SEG0) after writing Display Data into address = 4Fh (for SEG79). In case of Static Drive Mode, maximum address is 13h (for SEG76 to SEG79).

The DDRAM address map is same as the one in 2-wire Serial Interface (Refer to [Figure 12. DDRAM Address Map in Write Mode](#)).

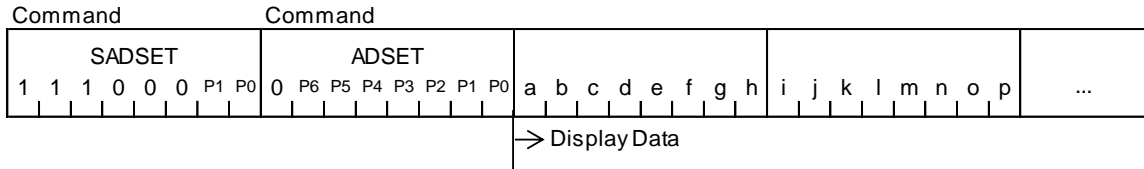

Figure 20. Display Data Transfer and Bit Assignment in 3-SPI

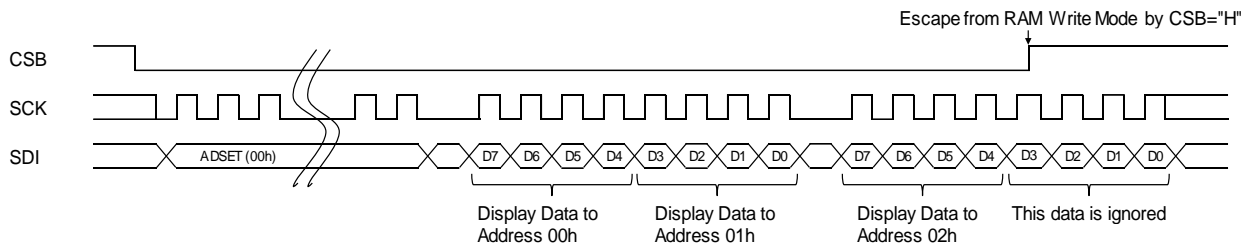

Figure 21. Case of Less Than 4-bit Write Data Transfer in 3-SPI

MCU Interface - continued

Display Data Read-back Method (3-SPI)

Set Read_en = "1" and Read_data = "1" in RDCTL register to enter to Display Data Read Mode. The Display Data values can be read during this mode. The sequence of the Display Data Read-back is shown below.

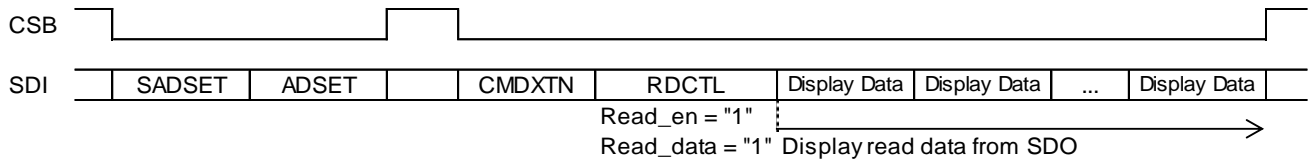

Figure 22. Display Data Read-back in 3-SPI

During Display Data Read Mode, the Display Data can be read from the DDRAM through the SDO line. The data will output synchronized with falling edge of SCK input.

SADSET and ADSET must be set first during Write Mode in advance. If DDRAM address is not specified before Display Data read, the current DDRAM address is used as the first read address. Address will be incremented automatically by +2 addresses after 8-bit data output. The Address will be set to 00h automatically after maximum address. Display Data Read Mode will be released by setting CSB to high (SDO output also be stopped).

The DDRAM address map is same as the one in 2-wire Serial Interface (Refer to [Figure 15. DDRAM Address Map in Read Mode](#)).

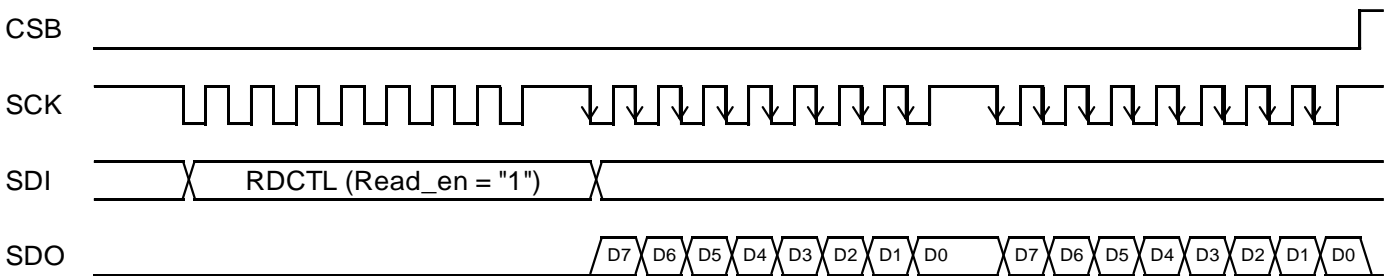

Figure 23. Bit Assignment in Display Data Read-back in 3-SPI

Command Registers Read-back Method (3-SPI)

Set Read_en = "1" and Read_data = "0" in RDCTL register to enter Command Registers Read Mode. The Command Registers values can be read during this mode. The sequence of the Command Registers read-back is shown below.

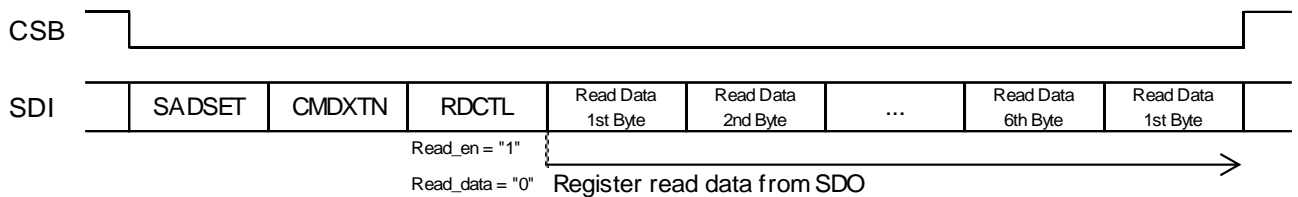

Figure 24. Command Registers Read-back in 3-SPI

After reading the 6th byte data, the first byte data will be output again. Command Registers Read Mode will be released after CSB change from low to high. (SDO stops).

The Command Registers Map is same as the one in 2-wire. Refer to [Table 3. Command Registers Map for Read-back](#).

OSC (Oscillator)

In master chip (MS1 = VSS and MS2 = VSS), the clock mode can be selected by EXTCLK. The clock signals for logic and analog circuit can be generated in internal oscillator if EXTCLK = VSS or can be provided from external clock input if EXTCLK = VDD.

Clock Mode	EXTCLK	OSCIO
Internal Clock Mode	VSS	To Output Internal Generated Clock Signal
External Clock Mode	VDD	To Input External Clock

In cascaded connection, slave chip (MS1 = VDD or MS2 = VDD) is always in External Clock Mode regardless of EXTCLK.

In case of External Clock Mode, a clock signal should be always supplied to BU91R64CH-M. Removing the clock may freeze the LCD in a DC state which is not suitable for the LCD.

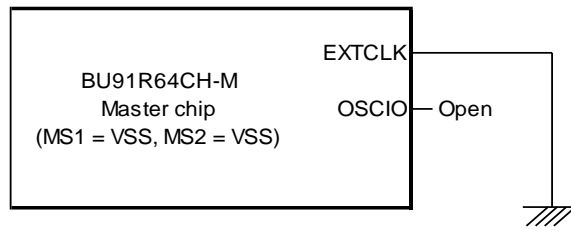

Figure 25. Internal Clock Mode

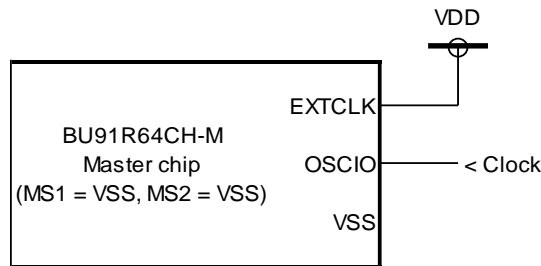

Figure 26. External Clock Mode

SYNC CTRL (Multi-chip Structure)

BU91R64CH-M supports large display application by connecting up to four IC in cascade. BU91R64CH-M can be combined with BU91R65CH-M and BU91R66CH-M.

The relationship of MS1 / MS2 setting, OSCIO, SYNCB and SADSET are shown below. To synchronize each IC, connect the synchronizing signal (SYNCB) and the synchronous clock (OSCIO) from the Master to Slave ICs.

In case of 2-wire Serial Interface

MS2	MS1	Mode	Slave Address [7:1]	OSCIO				SYNCB		SADSET (P1,P0)
				EXTCLK = VDD (Note 1)		EXTCLK = VSS (Note 2)		I/O	Connected to	
VSS	VSS	Master	0111 110 / 0111 000	IN	MCU	OUT	Slave1 to Slave3 (OSCIO)	OUT	Slave1 to Slave3 (SYNCB)	(0,*)
VSS	VDD	Slave1	0111 111 / 0111 001	IN	MCU	IN	Master (OSCIO)	IN	Master (SYNCB)	(0,*)
VDD	VSS	Slave2	0111 110 / 0111 000	IN	MCU	IN	Master (OSCIO)	IN	Master (SYNCB)	(1,*)
VDD	VDD	Slave3	0111 111 / 0111 001	IN	MCU	IN	Master (OSCIO)	IN	Master (SYNCB)	(1,*)

(*: don't care)

(Note 1) Frame rate is fixed (24 clock / frame) regardless of FRSET and MODESET3.

(Note 2) Frame rate depends on FRSET and MODESET3. All of Master and Slave1 to Slave3 must be same setting in the registers.

In case of 3-wire Serial Interface

MS2	MS1	Mode	OSCIO				SYNCB		SADSET (P1,P0)
			EXTCLK = VDD (Note 1)		EXTCLK = VSS (Note 2)		I/O	Connected to	
VSS	VSS	Master	IN	MCU	OUT	Slave1 to Slave3 (OSCIO)	OUT	Slave1 to Slave3 (SYNCB)	(0, 0)
VSS	VDD	Slave1	IN	MCU	IN	Master (OSCIO)	IN	Master (SYNCB)	(0, 1)
VDD	VSS	Slave2	IN	MCU	IN	Master (OSCIO)	IN	Master (SYNCB)	(1, 0)
VDD	VDD	Slave3	IN	MCU	IN	Master (OSCIO)	IN	Master (SYNCB)	(1, 1)

(Note 1) Frame rate is fixed (24 clock / frame) regardless of FRSET and MODESET3.

(Note 2) Frame rate depends on FRSET and MODESET3. All of Master and Slave1 to Slave3 must be same setting in the registers.

SYNC CTRL (Multi-chip Structure) - continued

The relationship between COM and SYNCB timing is as follows.

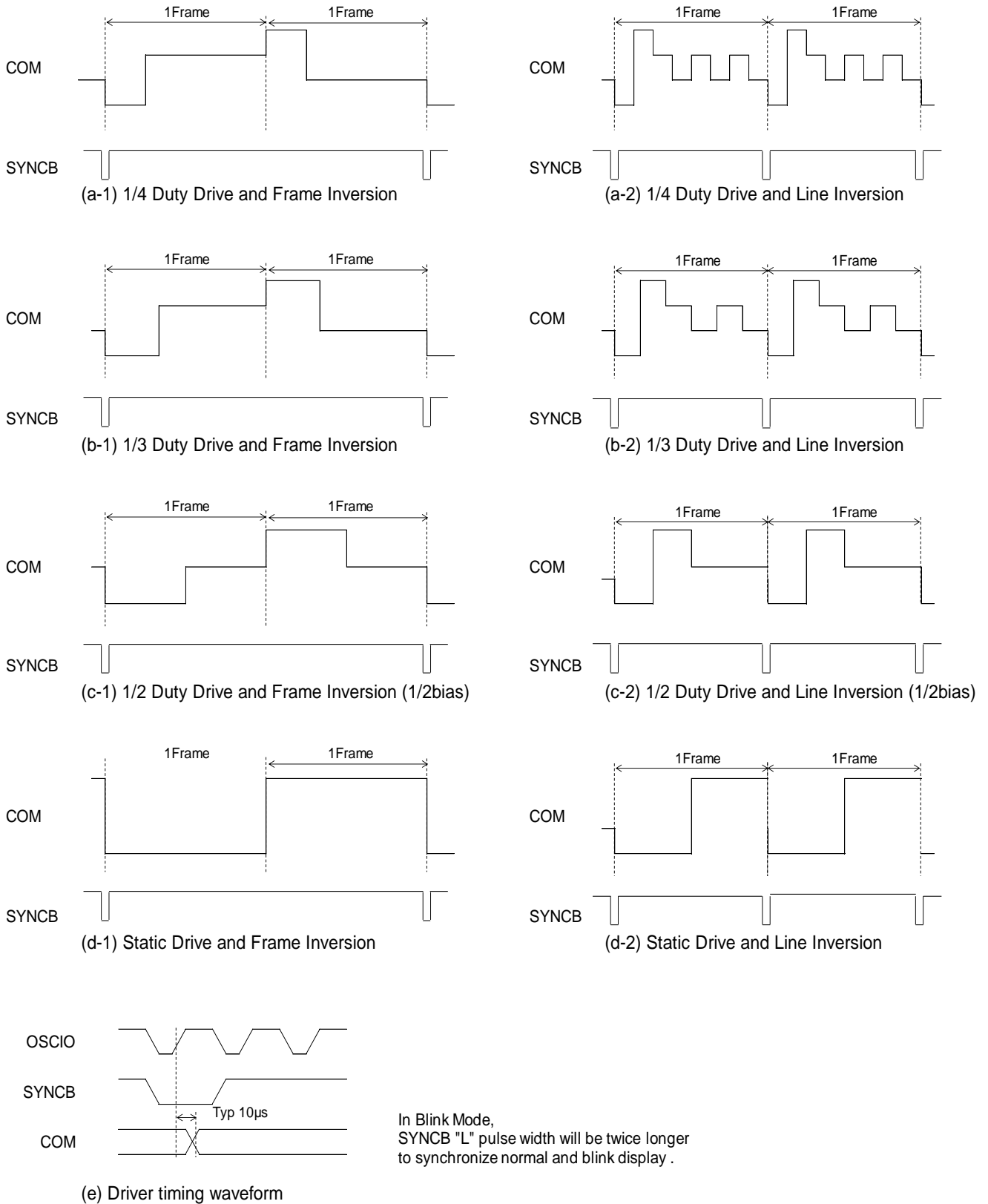
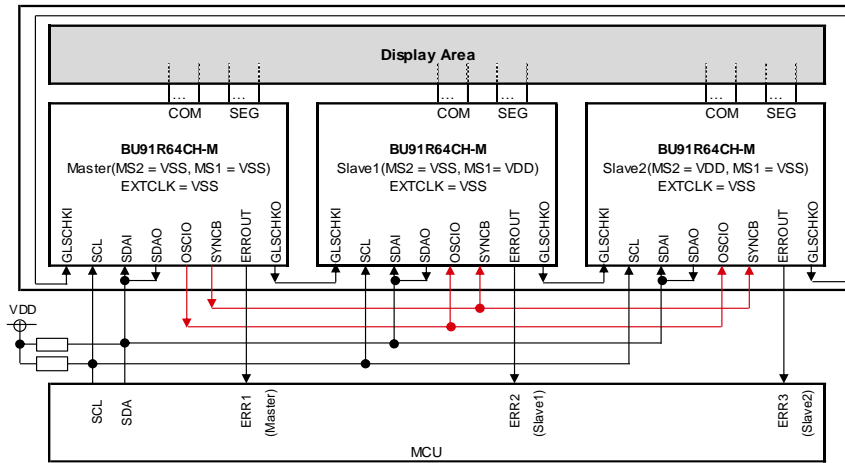

Figure 27. Synchronization of Multi-chip Cascaded Connection

SYNC CTRL (Multi-chip Structure) - continued

The example of cascaded connection

<2-wire serial, Internal Clock Mode, Detection enable>



<3-wire serial, External Clock Mode, Detection disable>

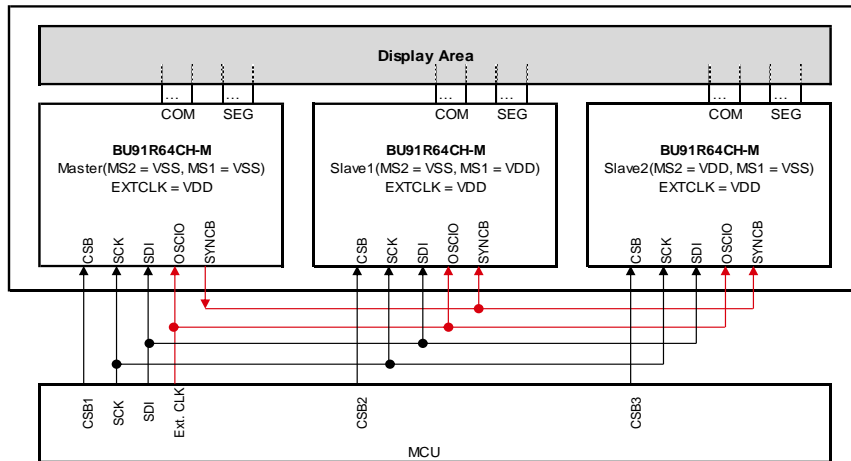

Figure 28. Example of Cascaded Connection

<Different Duty Panel Combination>

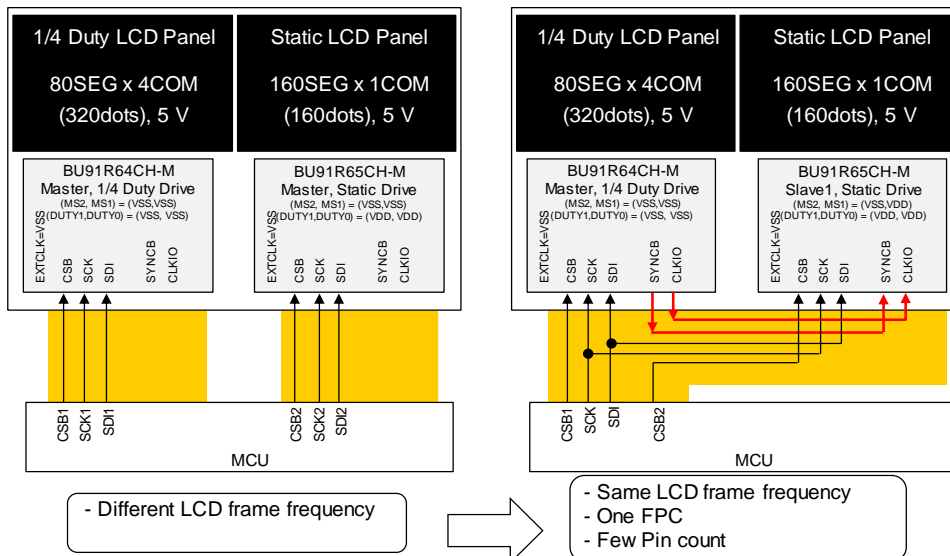

Figure 29. Example Different Duty Drive Panel Configuration

LCD Driver Voltage Generator / LCD Bias Selector

BU91R64CH-M generates LCD driving voltage with on-chip Buffer AMP. 1/3 or 1/2 Bias Drive can be selected by external terminal (BIAS) setting. Line / frame inversion can be set by MODESET3 command. Refer to [LCD Driving Waveform](#).

POR and Reset Initialize Condition

BU91R64CH-M has POR (Power On Reset) circuit. Keep Power On / Off specification and sequence described in [Cautions in Power On / Off](#). Initial condition after executing Software Reset and POR is as follows.

- Display is off.
- DDRAM address is initialized (DDRAM Data is not initialized).
- Each Command Registers are reset initialize condition. Refer to [Detailed Command Description](#).

Blink Control (Blink Timing Generator)

Blink function is asserted by Blink Control1 command (BLKCTL1). In All Segments Blink Mode, all dots blink is available. In Bank Blink Mode, individual dot blink is available only in 1/2 Duty and Static Drive mode. Refer to [5. Blink Control1 \(BLKCTL1\)](#). The Displayed RAM mapping is switched at blink frequency as following images.

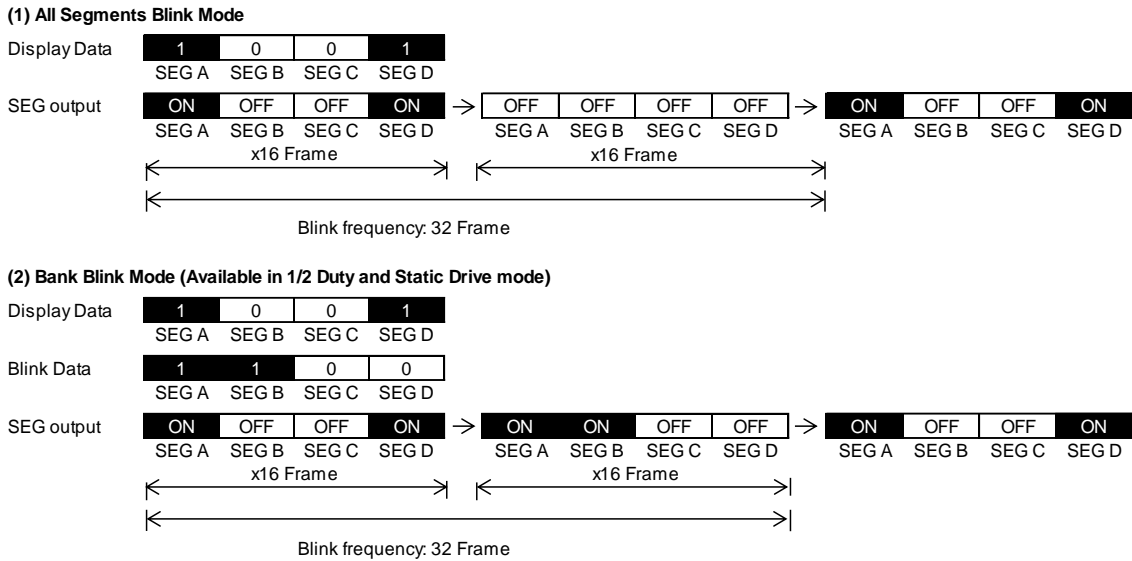

Figure 30. Bank Blink Mode Function (Blink Frequency as 32 Frame Case)

Blink data can be written in Blink Control 2 command (BLKCTL2) P1 = "1". The command sequence and the relationship between data input and DDRAM Address Map are as follows.

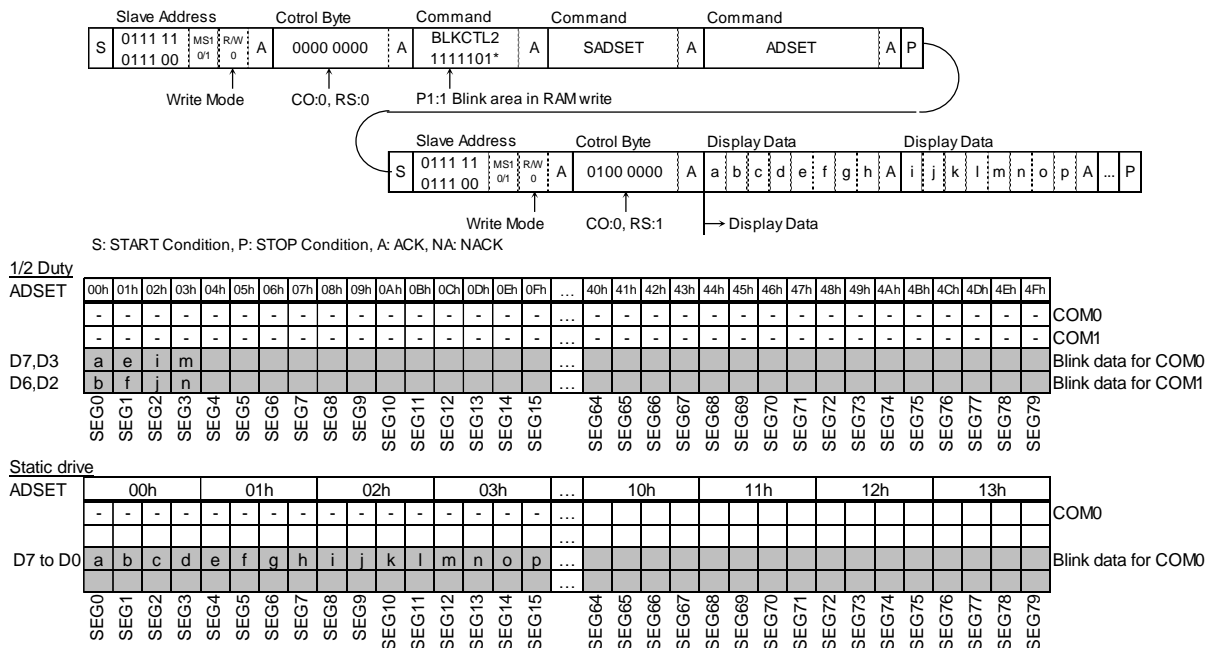

Figure 31. DDRAM Address Map of Blink Area (Bank Blink Mode)

Error Detection

BU91R64CH-M has the following Error Detection functions. When one of functions in a following table detects abnormal status, ERROUT terminal output high level. Then the item with abnormal status can be identified by reading Command Registers.

MCU can detect all events which cause abnormal display by these functions. MCU can take action such as Stopping the display or displaying information about abnormal state when LCD module encountered problem.

Table 4. Detection Functions

Item	Detected Error	Detection Function Availability	Detection Timing
Glass Breaking Detection	LCD Glass Breaking	During DISPON	By DISPON Command
Checksum Detection	I/F Communication Error	Always	By CHKSUM Command
Logic Error Detection	Logic DFF Malfunction	During DISPON	Always in DISPON
SEG / COM Toggle Detection	SEG / COM Output Level Error	During DISPON	Always in DISPON
Contact Resistance Check	COG Bonding Status	(No Power Applied)	(In LCD Module Assembly)

Block diagram and data path of Detection block are shown below.

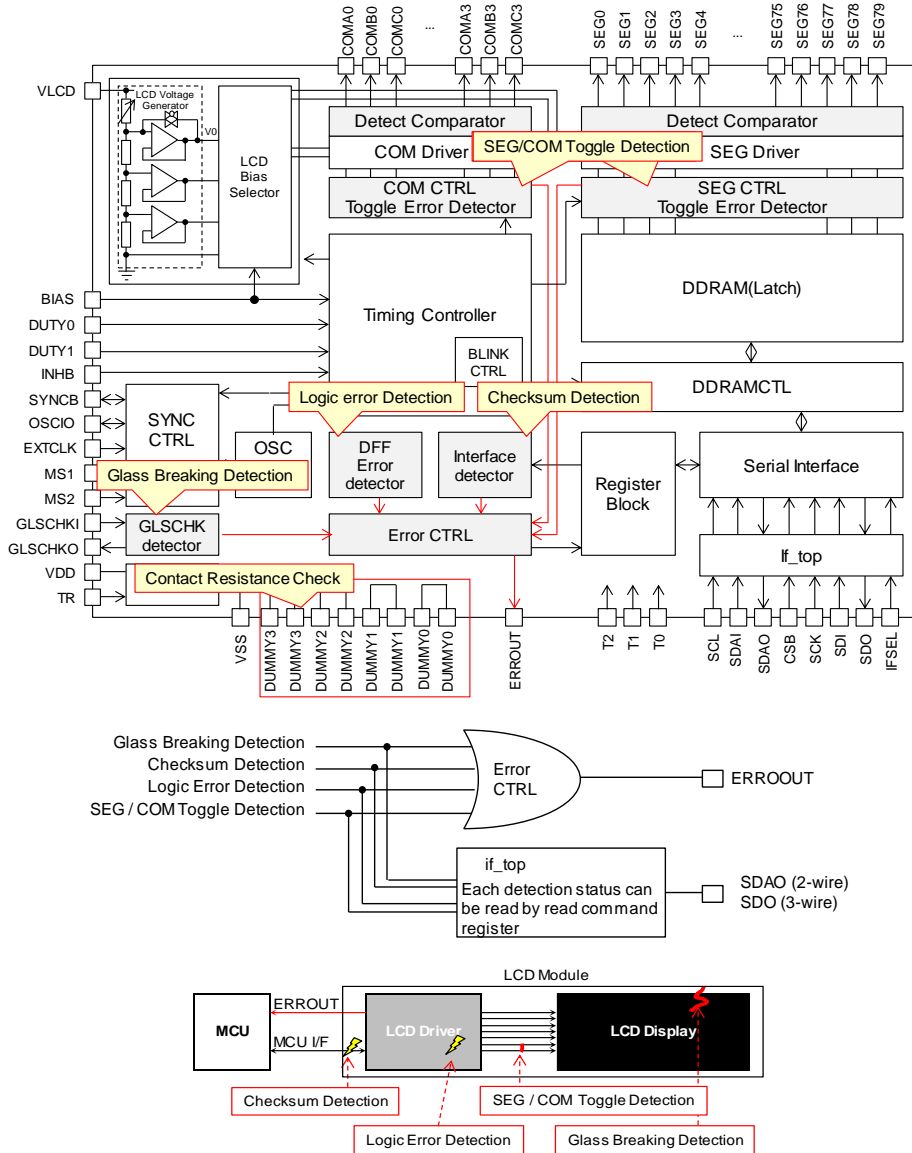

Figure 32. Detection Block and Data Path

Error Detection - continued

Glass Breaking Detection

BU91R64CH-M can detect LCD glass breaking status.

In Single-chip Use Case,

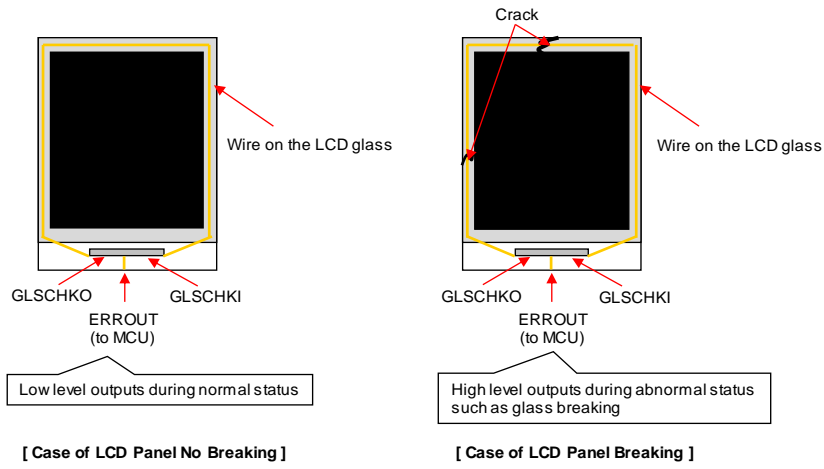

In Multi-chip Cascaded Use Case,

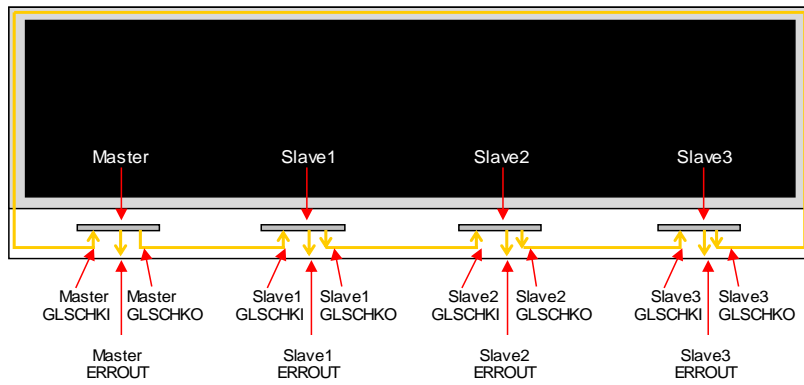

Figure 33. Glass Breaking Detection

Glass Breaking Detection – continued

Glass breaking detection will be judged after 4 frames from MODESET1 command (DISPON). High level will be judged at the end of the second frame after MODESET1 command (DISPON) and low level will be judged at the end of the fourth frame after the command. See following sequence.

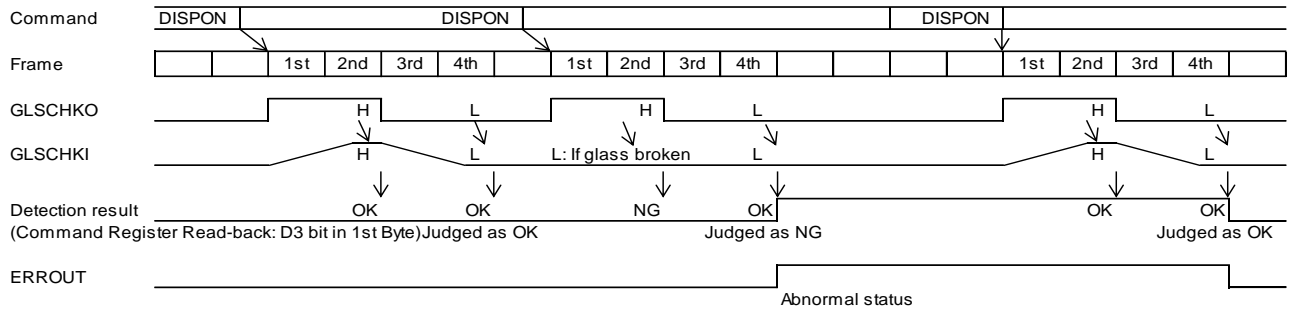

Figure 34. Sequence of Glass Breaking Detection

Thus, the detection period depends on the Frame Frequency setting. It is necessary to consider ITO wiring resistance and capacitance to keep the following calculation:

$$2 \times \tau < 2 \times \text{Frame Duty} \quad [\text{s}] \quad (\text{A})$$

where:

τ is the CR time constant. $\tau = C \times R$. C : ITO capacitance, R : ITO resistance.

<Calculation example>

When Frame rate = 200 Hz, Wire length around LCD glass = 500 counts, ITO sheet count = 60 Ω and ITO capacitance = 100 pF

$$\text{ITO resistance} = 60[\Omega] \times 500 [\text{count}] = 30,000 \quad [\Omega]$$

$$2 \times \tau = 2 \times C \times R = 2 \times 100[\text{pF}] \times 30[\text{k}\Omega] = 6 \quad [\mu\text{s}]$$

$$2 \times \text{Frame Duty} = 2 \times \frac{1}{200} = 10 \quad [\text{ms}]$$

In this case, (A) is satisfied. So glass check function will work correctly.

Error Detection - continued

Checksum Detection

This function detects the error due to command or Display Data alteration by electric noise during transfer from MCU. Checksum detection will be judged after every CHKSUM command. See following sequence.

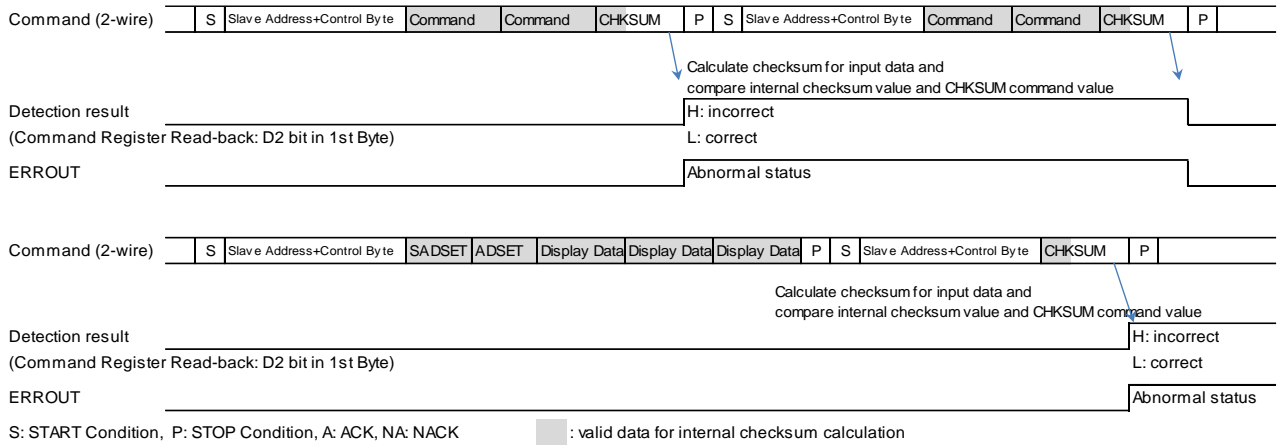
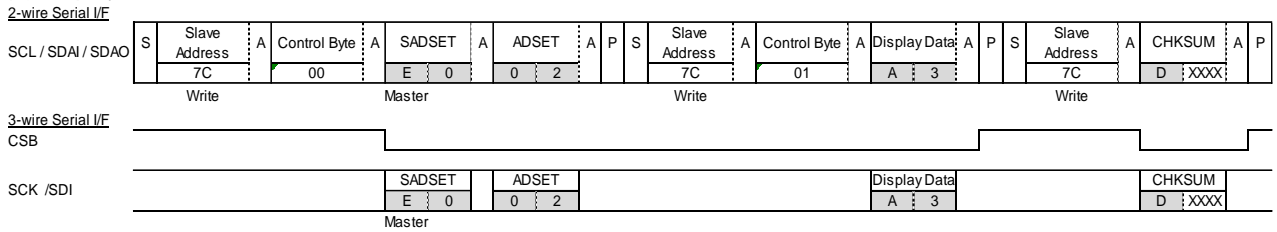

Figure 35. Sequence of Checksum Detection

Checksum calculation example:

(1) Display Data Write Case



(2) Command Registers Read Case (Read values are not used for checksum calculation.)

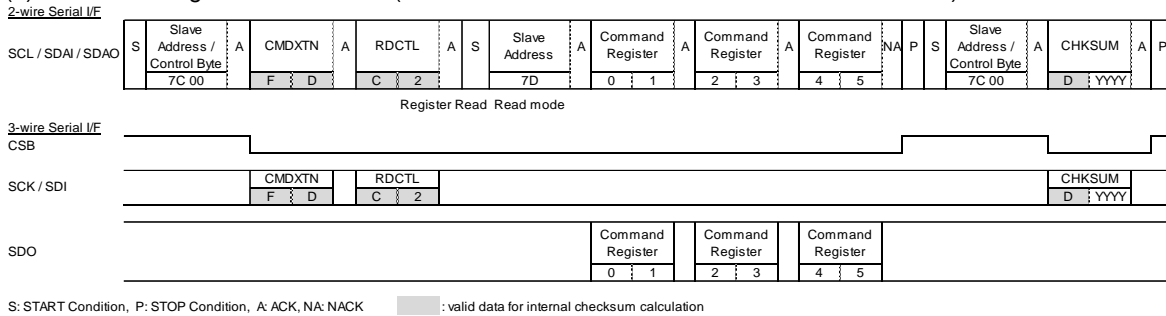

Calculation (1) RAM Write Case			Calculation (2) Read Case		
	Hex	Dec		Hex	Dec
SADSET upper 4-bit	E	14	CMDXTN upper 4-bit	F	15
SADSET lower 4-bit	0	0	CMDXTN lower 4-bit	D	13
ADSET upper 4-bit	0	0	RDCTL upper 4-bit	C	12
ADSET lower 4-bit	2	2	RDCTL lower 4-bit	2	2
Display Data upper 4-bit	A	10	CHKSUM upper 4-bit	D	13
Display Data lower 4-bit	3	3	Sum	37	55
CHKSUM upper 4-bit	D	13			
Sum	2A	42			

-> "XXXX" = "Ah"

-> "YYYY" = "7h"

Figure 36. Example of Checksum Calculation

In 2-wire, the checksum calculation value will be same in ICs which use same Slave Address and different sub address. In 3-wire, all IC's checksum values will be same.

Error Detection - continued

Logic Error Detection

This function detects occurrence of registers (DFF) errors due to electric noise. DFFs for detection are placed around logic area. Judgement is always proceeding in DISPON status. Logic error detection will be judged after every 2 frames from DISPON command. See following sequence.

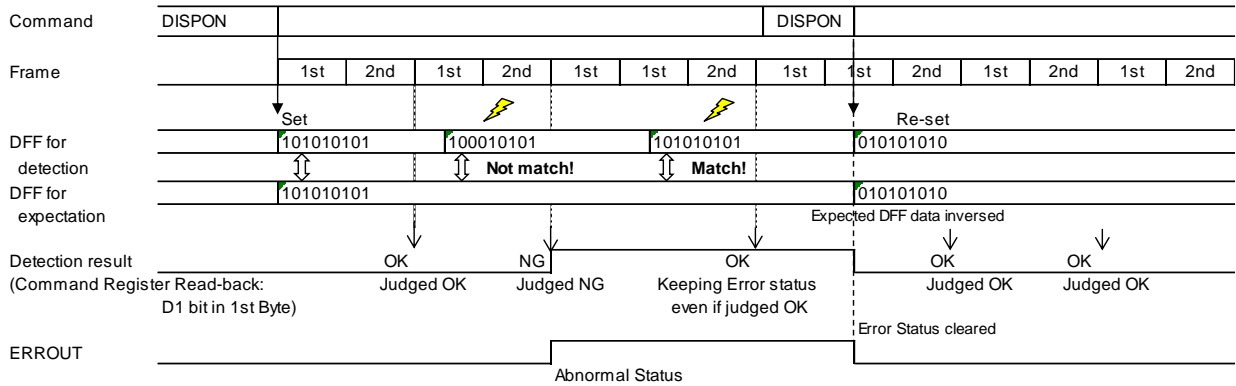

Figure 37. Sequence of Logic Error Detection

Error Detection - continued

SEG / COM Toggle Detection

This function is to detect whether SEG / COM output toggle (AC inversion) in DDRAM data bit = "1". Detectable status are considered as following conditions,

- (1) SEG / COM waveform stuck at VSS level (SEG can detect in DDRAM data bit = "1" case only).
 - (a) LCD broken.
 - (b) ITO wiring connected to VSS line.
 - (c) SEG / COM output broken such as short with VSS level.
- (2) SEG / COM waveform stuck at V0 level (SEG can detect in DDRAM data bit = "1" case only).
 - (a) LCD broken.
 - (b) ITO wiring connected to VLCD line.
 - (c) SEG / COM output broken such as short with VLCD / V0 level.

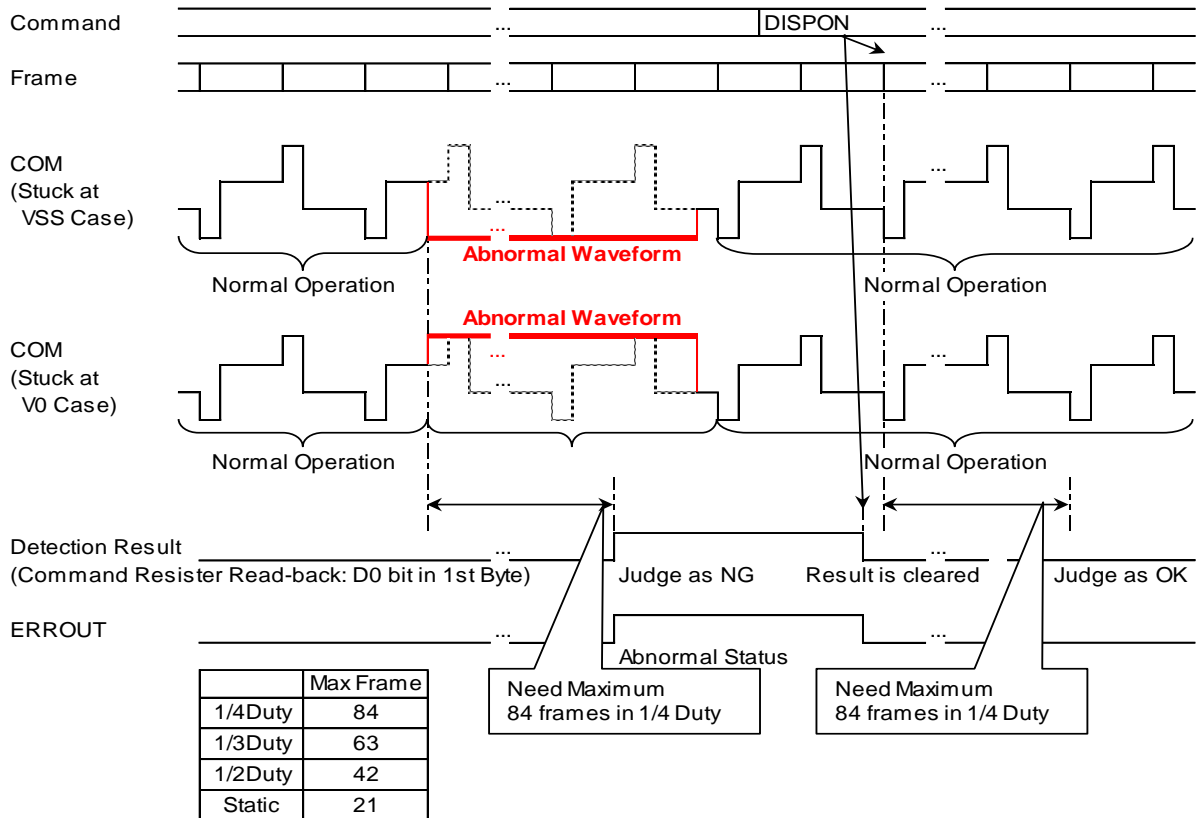

Figure 38. Sequence of SEG / COM Toggle Detection

Contact Resistance Check

COG contact resistance can be inspected by measuring resistance in DUMMY0, DUMMY1, DUMMY2 and DUMMY3 terminals. Abnormal COG bonding status can be detected if the values are outliers.

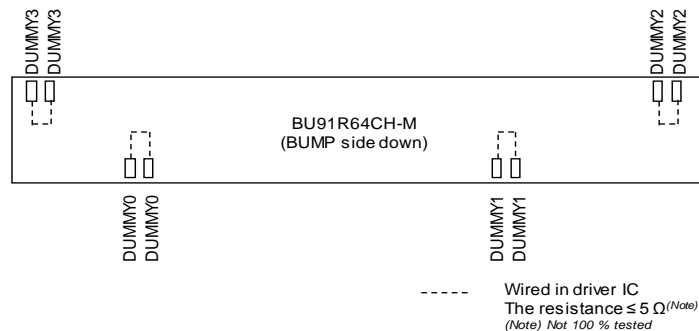

Figure 39. DUMMY PADs for the Contact Resistance Measurement

Command / Function List

Description List of Command / Function

No.	Command	Function	Identify Sub Address by SADSET	Available in CMDXTN Mode
Normal Command				
1	Mode Set 1(MODESET1)	Display On / Off	-	No
2	Address Set (ADSET)	DDRAM Address Setting	-	No
3	Sub Address Set (SADSET)	IC Selecting	-	No
4	Frame Rate Set (FRSET)	Frame Frequency	-	No
5	Blink Control1 (BLKCTL1)	Blink Mode / Blink Frequency Setting	-	No
6	Blink Control2 (BLKCTL2)	Blink Area Setting	-	No
7	Command Extension (CMDXTN)	Access enable for extended commands	-	-
Extension Command				
8	Software Reset (SWRST)	Software Reset	-	Yes
9	Mode Set 2(MODESET2)	Error Detection Control	-	Yes
10	Mode Set 3(MODESET3)	Line / Frame Inversion, Frame Frequency	-	Yes
11	Contrast Setting (CNTSET)	Contrast adjustment	Yes	Yes
12	Read Control (RDCTL)	Read Control	-	Yes
13	Checksum(CHKSUM)	Checksum Trigger and Expected Value	-	Yes
14	COM Set (COMSET)	COM driving order select, Contrast adjustment	Yes	Yes

Detailed Command Description**1. Mode Set 1 (MODESET1)**

MSB							LSB
D7	D6	D5	D4	D3	D2	D1	D0
1	1	0	0	P3	*	*	*

(*: don't care)

Set Display On and Off

P3	Setup	Reset Initialize Condition
0	Display Off (DISPOFF)	○
1	Display On (DISPON)	-

Display Off: Regardless of DDRAM data, all Segment and Common output will be stopped (VSS level).

Display On: Segment and Common output will be active and will start to read the Display Data from DDRAM.

Detailed Command Description – continued

2. Address Set (ADSET)

MSB							LSB
D7	D6	D5	D4	D3	D2	D1	D0
0	P6	P5	P4	P3	P2	P1	P0

Set address. (P6 to P0 = "0000000" in reset initialize condition)
 Don't set out of range address, otherwise address will be set to "0000000".
 In 3-SPI case, next transferred data will be recognized as Display Data.

The range of address (7-bit) is shown as bellow.
 1/4, 1/3 and 1/2 Duty Drive mode: 00h to 4Fh
 Static Drive Mode: 00h to 13h

3. Sub Address Set (SADSET)

MSB							LSB
D7	D6	D5	D4	D3	D2	D1	D0
1	1	1	0	0	0	P1	P0

Set sub address to define one of BU91R6xCH sub address.
 The following command can be set independently after SADSET command.

- Display Data write
- Display Data read
- Command Registers read
- Contrast Setting (CNTSET)
- COM set (COMSET)

In 2-wire Serial Interface mode

P1	P0	Available IC	Reset Initialize Condition
0	*	Master or Slave1 ^(Note 1) (MS2 = VSS)	○
1	*	Slave2 or Slave3 ^(Note 1) (MS2 = VDD)	-

(Note 1): Bit1 of Slave Address selects one of "Master / Slave1" or one of "Slave2 / Slave3".
 (*: don't care)

In 3-wire Serial Interface mode

P1	P0	Available IC	Reset Initialize Condition
0	0	Master (MS2 = VSS, MS1 = VSS)	○
0	1	Slave1 (MS2 = VSS, MS1 = VDD)	-
1	0	Slave2 (MS2 = VDD, MS1 = VSS)	-
1	1	Slave3 (MS2 = VDD, MS1 = VDD)	-

Detailed Command Description – continued

4. Frame Rate Set (FRSET)

MSB				LSB			
D7	D6	D5	D4	D3	D2	D1	D0
1	1	1	0	1	P2	P1	P0

Set Frame Frequency

In Internal Clock Mode, Frame Frequency is calculated as shown in the following table.

Table 5. Frame Frequency (Internal Clock Mode)

MODESET3		FRSET			Frame Frequency [Hz] (Number of Clock Pulses)		Reset Initialize Condition
P1	P0	P2	P1	P0	Line Inversion	Frame Inversion	
0	0	0	0	0	65.7 (624)		-
0	0	0	0	1	74.3 (552)		-
0	0	0	1	0	85.4 (480)		-
0	0	0	1	1	122.0 (336)		-
0	0	1	0	0	131.4 (312)		-
0	0	1	0	1	142.4 (288)		-
0	0	1	1	0	155.3 (264)		○
0	0	1	1	1	170.8 (240)		-
0	1	0	0	0	189.8 (216)		-
0	1	0	0	1	213.5 (192)		-
0	1	0	1	0	244.0 (168)		-
0	1	0	1	1	284.7 (144)		-
0	1	1	0	0	427.1 (96)		-
0	1	1	0	1	569.4 (72) (Prohibited)		-
0	1	1	1	0	854.2 (48) (Prohibited)		-
0	1	1	1	1	1708.3 (24) (Prohibited)		-
1	0	0	0	0	65.7 (624)	131.4 (312)	-
1	0	0	0	1	74.3 (552)	148.6 (276)	-
1	0	0	1	0	85.4 (480)	170.8 (240)	-
1	0	0	1	1	122.0 (336)	244.0 (168)	-
1	0	1	0	0	131.4 (312)	262.8 (156)	-
1	0	1	0	1	142.4 (288)	284.7 (144)	-
1	0	1	1	0	155.3 (264)	310.6 (132)	-
1	0	1	1	1	170.8 (240)	341.7 (120)	-
1	1	0	0	0	189.8 (216)	379.6 (108)	-
1	1	0	0	1	213.5 (192)	427.1 (96)	-
1	1	0	1	0	244.0 (168)	488.1 (84)	-
1	1	0	1	1	284.7 (144)	569.4 (72) (Prohibited)	-
1	1	1	0	0	427.1 (96)	854.2 (48) (Prohibited)	-
1	1	1	0	1	569.4 (72) (Prohibited)	1138.9 (36) (Prohibited)	-
1	1	1	1	0	854.2 (48) (Prohibited)	1708.3 (24) (Prohibited)	-
1	1	1	1	1	1708.3 (24) (Prohibited)	3416.7 (12) (Prohibited)	-

In External Clock Mode, Frame Frequency is calculated as shown in following table,

Table 6. Frame Frequency (External Clock Mode)

MODESET3		FRSET			Frame Frequency [Hz]		Reset Initialize Condition
P1	P0	P2	P1	P0	Line Inversion	Frame Inversion	
0	*	*	*	*	External Clock / 24		○
1	*	*	*	*	External Clock / 24	External Clock / 12	-

(*: don't care)

(Example 1)

EXTCLK = VDD

External Clock: 1,800 Hz

MODESET3 P1: 0

Frame Frequency = External Clock / 24 = 1,800 / 24 = 75 Hz @Line / Frame Inversion

(Example 2)

EXTCLK = VDD

External Clock: 3,500 Hz

MODESET3 P1: 1

Frame Frequency = External Clock / 24 = 3,500 / 24 = 145.8 Hz @Line Inversion

Frame Frequency = External Clock / 12 = 3,500 / 12 = 291.7 Hz @Frame Inversion

Detailed Command Description – continued

5. Blink Control1 (BLKCTL1)

MSB						LSB	
D7	D6	D5	D4	D3	D2	D1	D0
1	1	1	1	0	P2	P1	P0

Set Blink Mode

P2	Blink Mode	Reset Initialize Condition
0	All Segments Blink Mode	○
1	Bank Blink Mode	-

Bank Blink Mode is available in 1/2 Duty Drive and Static Drive.

Set Blink Frequency

P1	P0	Blink Frequency	Reset Initialize Condition
0	0	Off	○
0	1	32 Frames	-
1	0	64 Frames	-
1	1	128 Frames	-

About Frame Frequency calculation, refer to [4. Frame Rate Set \(FRSET\)](#).

About Bank Blink Mode, refer to [Blink Control \(Blink Timing Generator\)](#).

6. Blink Control2 (BLKCTL2)

MSB						LSB	
D7	D6	D5	D4	D3	D2	D1	D0
1	1	1	1	1	0	P1	*

(*: don't care)

Set Blink Area in 1/2 Duty Drive and Static Drive in Bank Blink Mode

P1	DDRAM Write Area	Reset Initialize Condition
0	Normal Display Area	○
1	Blink Area	-

This register is available only in 1/2 Duty Drive and Static Drive.

About data writing to blink area, refer to [Blink Control \(Blink Timing Generator\)](#).

Detailed Command Description – continued

7. Command Extension (CMDXTN)

MSB							LSB
D7	D6	D5	D4	D3	D2	D1	D0
1	1	1	1	1	1	0	P0

Set CMDXTN Mode Effective

P0	Mode	Reset Initialize Condition
0	Ineffective CMDXTN Mode (Normal Mode)	○
1	CMDXTN Mode (Extension Mode)	-

The following extension commands are accessible only in CMDXTN mode,

1. SWRST
2. MODESET2
3. MODESET3
4. CNTSET
5. RDCTL
6. CHKSUM
7. COMSET

To access normal command such as DISPON etc., set P0 = "0" (ineffective CMDXTN mode).
Refer to [Command / Function List](#).

8. Software Reset (SWRST)

MSB							LSB
D7	D6	D5	D4	D3	D2	D1	D0
1	0	0	0	*	*	*	P0

(*: don't care)

This register can be accessed in CMDXTN mode only.

Set software reset effective

P0	Operation	Reset Initialize Condition
0	No Operation	○
1	Software Reset Execute	-

When "Software Reset" is executed, BU91R64CH-M will be reset to initial condition.
Refer to [POR and Reset Initialize Condition](#).

Detailed Command Description – continued

9. Mode Set 2 (MODESET2)

MSB							LSB
D7	D6	D5	D4	D3	D2	D1	D0
1	0	0	1	P3	P2	P1	P0

This register can be accessed in CMDXTN mode only.

Set Glass breaking detection to enable

P3	Setup	Reset Initialize Condition
0	Disable	○
1	Enable	-

Set Checksum detection to enable

P2	Setup	Reset Initialize Condition
0	Disable	○
1	Enable	-

Set Logic error detection to enable

P1	Setup	Reset Initialize Condition
0	Disable	○
1	Enable	-

Set SEG / COM toggle detection to enable

P0	Setup	Reset Initialize Condition
0	Disable	○
1	Enable	-

ERROUT output function will be effective when any bit of P3 to P0 is set to enable, refer to [Detailed Command Description](#).

10. Mode Set 3 (MODESET3)

MSB							LSB
D7	D6	D5	D4	D3	D2	D1	D0
1	0	1	0	0	P2	P1	P0

This register can be accessed in CMDXTN mode only.

Set LCD Driving Mode

P2	Driving Mode	Reset Initialize Condition
0	Line Inversion Mode	○
1	Frame Inversion Mode	-

Power consumption is reduced in the following order: Line inversion > Frame inversion
Typically, when driving large capacitance LCD, Line inversion will increase the influence of crosstalk.
Regarding driving waveform, refer to [LCD Driving Waveform](#).

Set x2 Frame frequency in Frame inversion mode

P1	Mode	Reset Initialize Condition
0	Normal Frequency Mode	○
1	x2 Frequency in Frame Inversion	-

This command is only effective in Frame inversion mode.

In detail, refer to [4. Frame Rate Set \(FRSET\)](#).

Set Frame Frequency Mode

P0	Frame Frequency Mode	Reset Initialize Condition
0	Normal Frequency Mode	○
1	High Frequency Mode	-

In detail, refer to [4. Frame Rate Set \(FRSET\)](#).

Detailed Command Description – continued

11. Contrast Setting (CNTSET)

MSB								LSB
D7	D6	D5	D4	D3	D2	D1	D0	
1	0	1	1	P3	P2	P1	P0	

This register can be accessed in CMDXTN mode only.
 This command can set sub address individually by SADSET command.

Set EVR for Contrast adjustment.

BU91R64CH-M is able to control V0 voltage level (the maximum level voltage of LCD driving) by a 32-step electrical volume register (EVR).

Table 7. V0 Voltage Setting

Unit: V

COMSET	CNTSET				Formula	VLCD [V]							Reset Initialize Condition
	P3	P3	P2	P1		P0	6.0	5.5	5.0	4.0	3.5	3.0	
0	0	0	0	0	1.000 * VLCD	6.000	5.500	5.000	4.000	3.500	3.000	2.500	O
0	0	0	0	1	0.967 * VLCD	5.802	5.323	4.839	3.871	3.387	2.903	2.419	-
0	0	0	1	0	0.937 * VLCD	5.622	5.156	4.688	3.750	3.281	2.813	2.344	-
0	0	0	1	1	0.909 * VLCD	5.454	5.000	4.545	3.636	3.182	2.727	2.273	-
0	0	1	0	0	0.882 * VLCD	5.292	4.853	4.412	3.529	3.088	2.647	2.206	-
0	0	1	0	1	0.857 * VLCD	5.142	4.714	4.286	3.429	3.000	2.571	2.143	-
0	0	1	1	0	0.833 * VLCD	4.998	4.583	4.167	3.333	2.917	2.500	2.083	-
0	0	1	1	1	0.810 * VLCD	4.860	4.459	4.054	3.243	2.838	2.432	2.027	-
0	1	0	0	0	0.789 * VLCD	4.734	4.342	3.947	3.158	2.763	2.368	1.974	-
0	1	0	0	1	0.769 * VLCD	4.614	4.231	3.846	3.077	2.692	2.308	1.923	-
0	1	0	1	0	0.750 * VLCD	4.500	4.125	3.750	3.000	2.625	2.250	1.875	-
0	1	0	1	1	0.731 * VLCD	4.386	4.024	3.659	2.927	2.561	2.195	1.829	-
0	1	1	0	0	0.714 * VLCD	4.284	3.929	3.571	2.857	2.500	2.143	1.786	-
0	1	1	0	1	0.697 * VLCD	4.182	3.837	3.488	2.791	2.442	2.093	1.744	-
0	1	1	1	0	0.681 * VLCD	4.086	3.750	3.409	2.727	2.386	2.045	1.705	-
0	1	1	1	1	0.666 * VLCD	3.996	3.667	3.333	2.667	2.333	2.000	1.667	-
1	0	0	0	0	0.652 * VLCD	3.912	3.587	3.261	2.609	2.283	1.957	1.630	-
1	0	0	0	1	0.638 * VLCD	3.828	3.511	3.191	2.553	2.234	1.915	1.596	-
1	0	0	1	0	0.625 * VLCD	3.750	3.438	3.125	2.500	2.188	1.875	1.563	-
1	0	0	1	1	0.612 * VLCD	3.672	3.367	3.061	2.449	2.143	1.837	1.531	-
1	0	1	0	0	0.600 * VLCD	3.600	3.300	3.000	2.400	2.100	1.800	1.500	-
1	0	1	0	1	0.588 * VLCD	3.528	3.235	2.941	2.353	2.059	1.765	1.471	-
1	0	1	1	0	0.576 * VLCD	3.456	3.173	2.885	2.308	2.019	1.731	1.442	-
1	0	1	1	1	0.566 * VLCD	3.396	3.113	2.830	2.264	1.981	1.698	1.415	-
1	1	0	0	0	0.555 * VLCD	3.330	3.056	2.778	2.222	1.944	1.667	1.389	-
1	1	0	0	1	0.545 * VLCD	3.270	3.000	2.727	2.182	1.909	1.636	1.364	-
1	1	0	1	0	0.535 * VLCD	3.210	2.946	2.679	2.143	1.875	1.607	1.339	-
1	1	0	1	1	0.526 * VLCD	3.156	2.895	2.632	2.105	1.842	1.579	1.316	-
1	1	1	0	0	0.517 * VLCD	3.102	2.845	2.586	2.069	1.810	1.552	1.293	-
1	1	1	0	1	0.508 * VLCD	3.048	2.797	2.542	2.034	1.780	1.525	1.271	-
1	1	1	1	0	0.500 * VLCD	3.000	2.750	2.500	2.000	1.750	1.500	1.250	-
1	1	1	1	1	0.491 * VLCD	2.946	2.705	2.459	1.967	1.721	1.475	1.230	-

Prohibited Setting

Avoid setting EVR of “V0 < 2.5V” and “V0 > VLCD – 0.6V” condition. BU91R64CH-M output voltage will be unstable in such conditions.

Detailed Command Description – continued

12. Read Control (RDCTL)

MSB							LSB
D7	D6	D5	D4	D3	D2	D1	D0
1	1	0	0	*	*	P1	P0

(*: don't care)

This register can be accessed in CMDXTN mode only.

Set Read enable (This bit is available in 3SPI mode only. In 2-wire, this bit is undefined.)

P1	Read_en	Reset Initialize Condition
0	Read disable (Write Mode)	○
1	Read enable (Read Mode)	-

Set Read data

P0	Read_mode	Reset Initialize Condition
0	Command Registers Read	○
1	DDRAM Data Read	-

13. Checksum (CHKSUM)

MSB							LSB
D7	D6	D5	D4	D3	D2	D1	D0
1	1	0	1	P3	P2	P1	P0

This register can be accessed in CMDXTN mode only.

P3 to P0: The sum of all Command Registers value for interface checksum function. Set this value after calculating the sum of each Command Registers value. In detail, refer to [Checksum Detection](#).

Detailed Command Description – continued

14. COM Set (COMSET)

MSB								LSB
D7	D6	D5	D4	D3	D2	D1	D0	
1	1	1	0	P3	P2	P1	P0	

This register can be accessed in CMDXTN mode only.
 This command can set sub address individually by SADSET command.

P3: Set MSB of CNTSET
 Refer to Contrast Setting command (CNTSET).

P2 to P0: Set COM scanning order of COMA, COMB and COMC individually.
 P2: Set COMC Scanning Order
 P1: Set COMB Scanning Order
 P0: Set COMA Scanning Order

P2 (COMC)	P1 (COMB)	P0 (COMA)	Duty Drive	Toggle Order of COM*0 to COM*3	Reset Initialize Condition
0	0	0	1/4 Duty	COM*0→COM*1→COM*2→COM*3	○
			1/3 Duty	COM*0→COM*1→COM*2 (Note 1)	
			1/2 Duty	COM*0→COM*1 (Note 2)	
			Static	COM*0 (Note 3)	
1	1	1	1/4 Duty	COM*3→COM*2→COM*1→COM*0	-
			1/3 Duty	COM*3→COM*2→COM*1 (Note 1)	
			1/2 Duty	COM*1→COM*0 (Note 2)	
			Static	COM*0 (Note 3)	

(*: A for P0, or B for P1, or C for P3)
 (Note 1) COMA3 = COMA0
 (Note 2) COMA2 = COMA0, COMA3 = COMA1
 (Note 3) COMA1 / 2 / 3 = COMA0

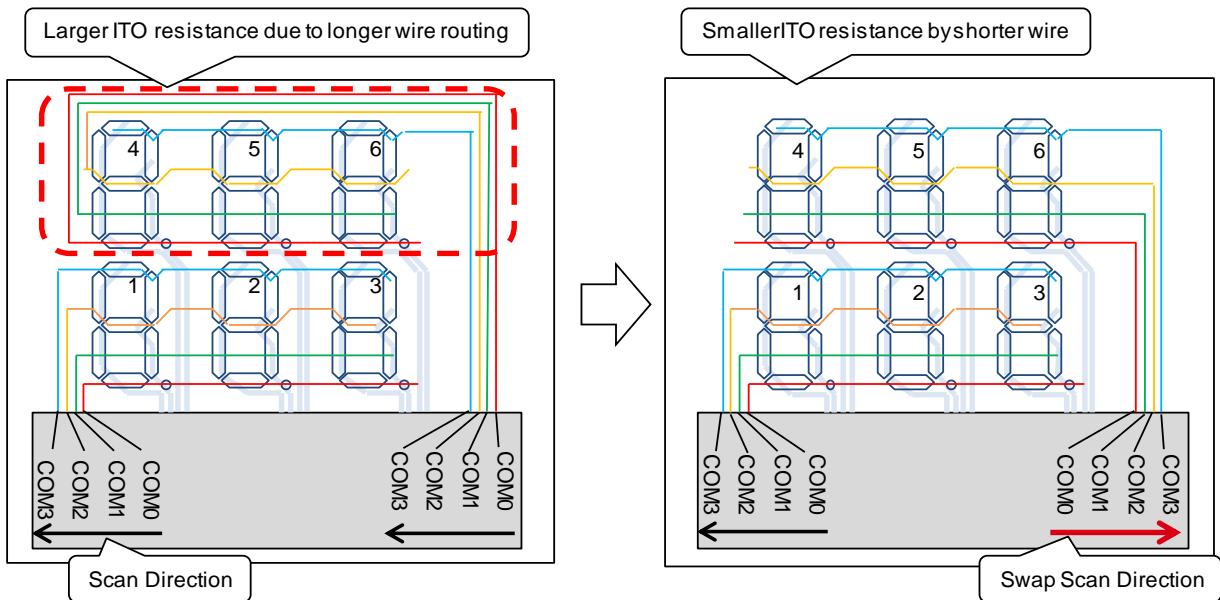
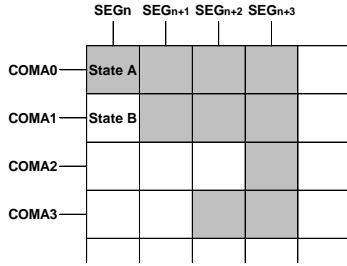

Figure 40. COM Scan Direction Image

LCD Driving Waveform

1/3 Bias, 1/4 Duty Drive

Frame Inversion



Line Inversion

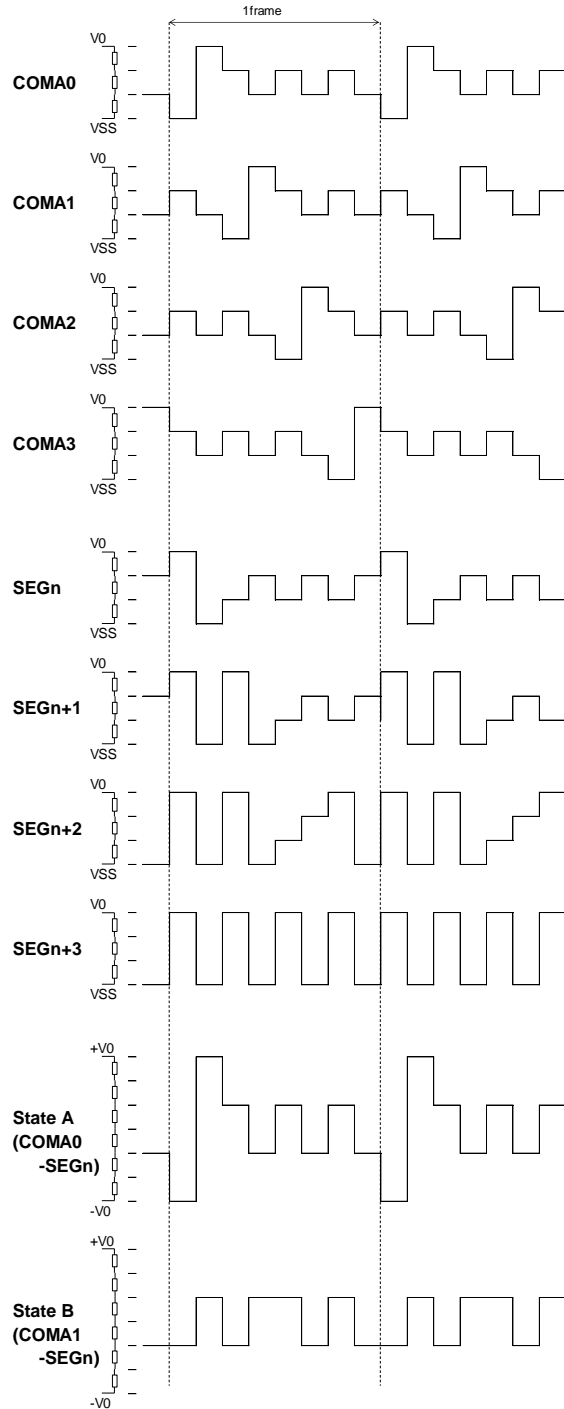
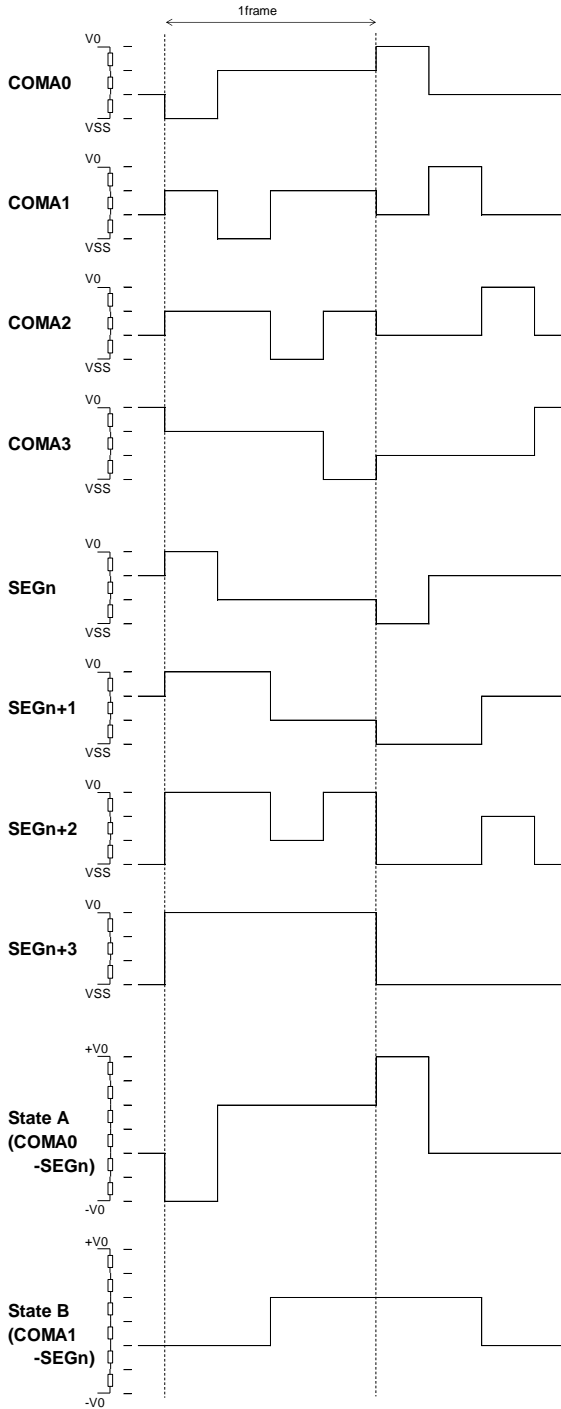
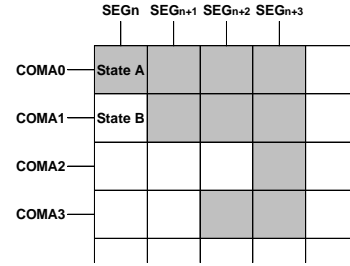

COMSET P2 = "0", Normally white type LCD case

LCD Driving Waveform - continued

1/2 Bias, 1/4 Duty Drive

Frame Inversion

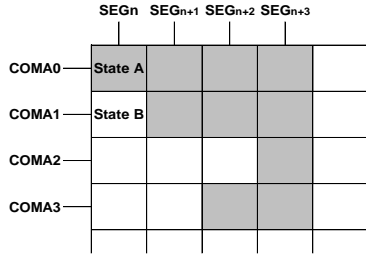

Line Inversion

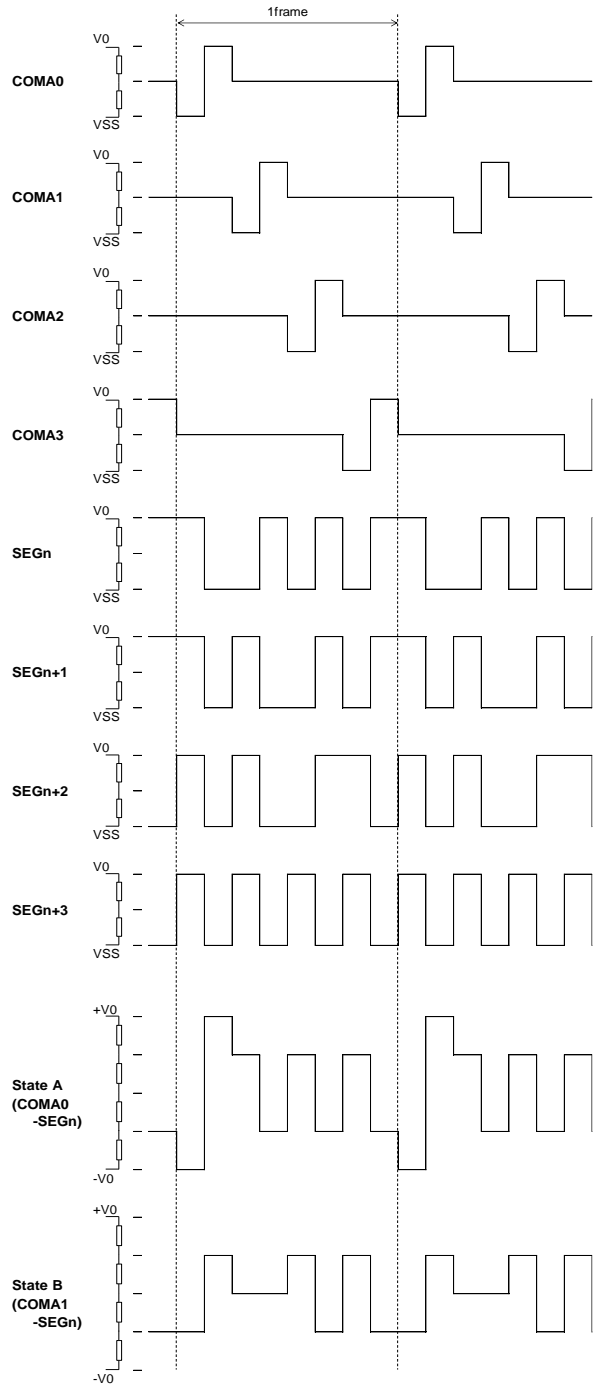
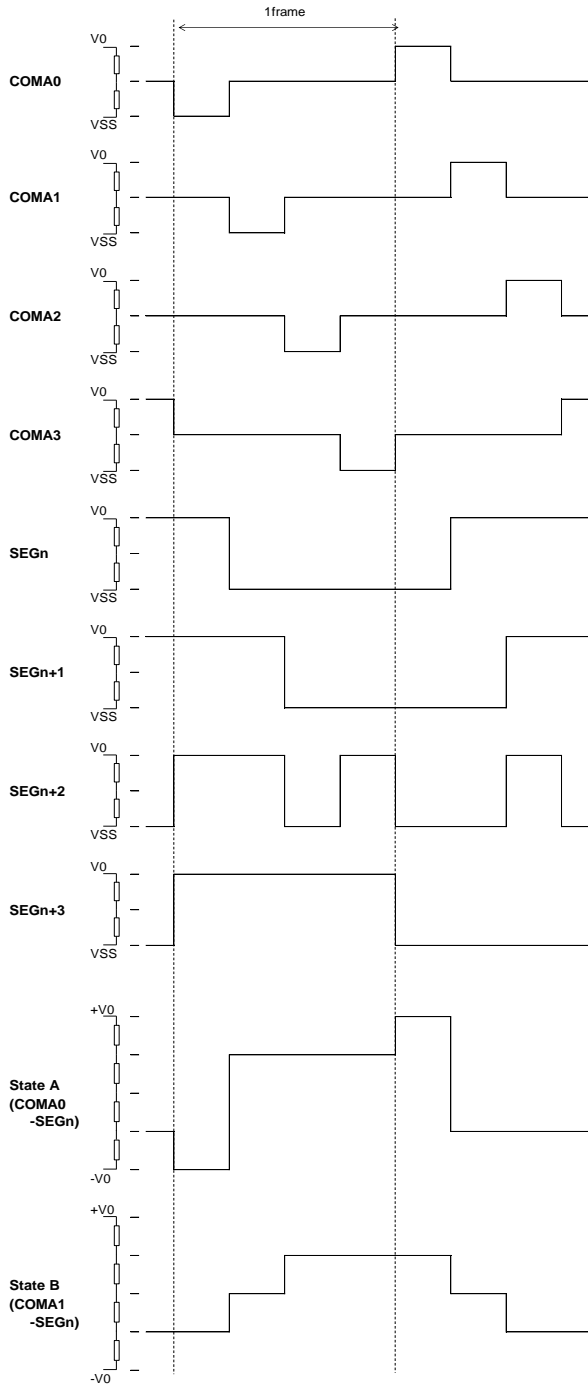
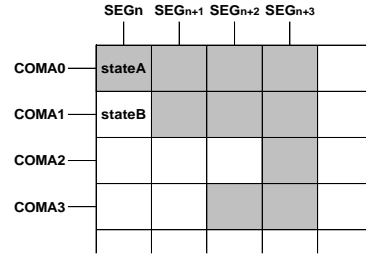

COMSET P2 = "0", Normally white type LCD case

LCD Driving Waveform - continued

1/3 Bias, 1/3 Duty Drive

Frame Inversion

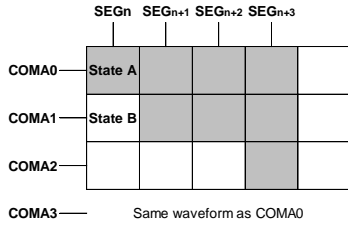

Line Inversion

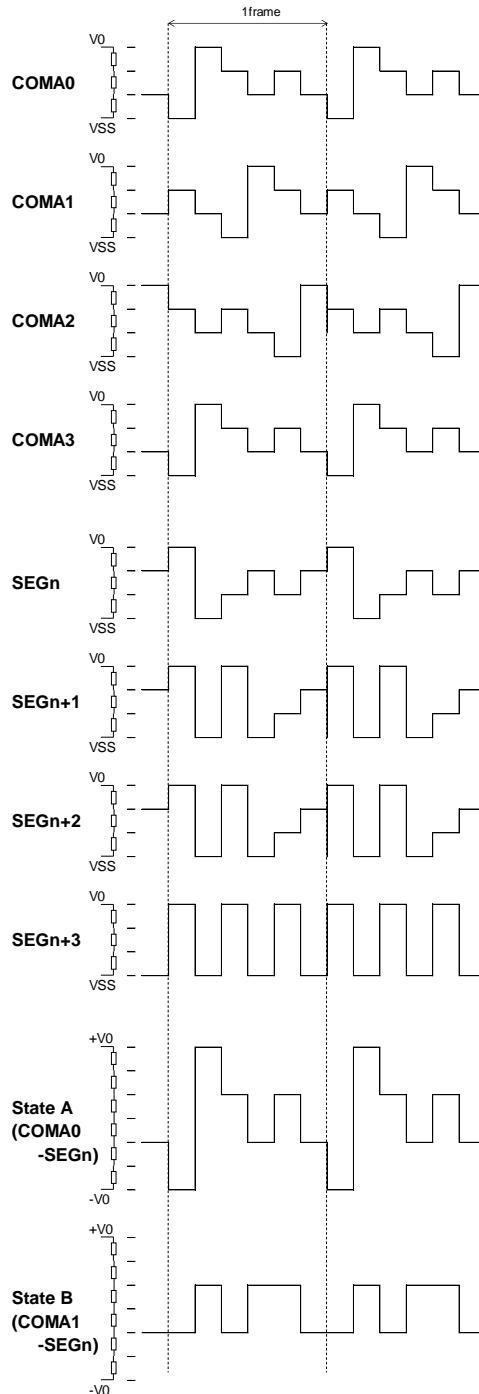
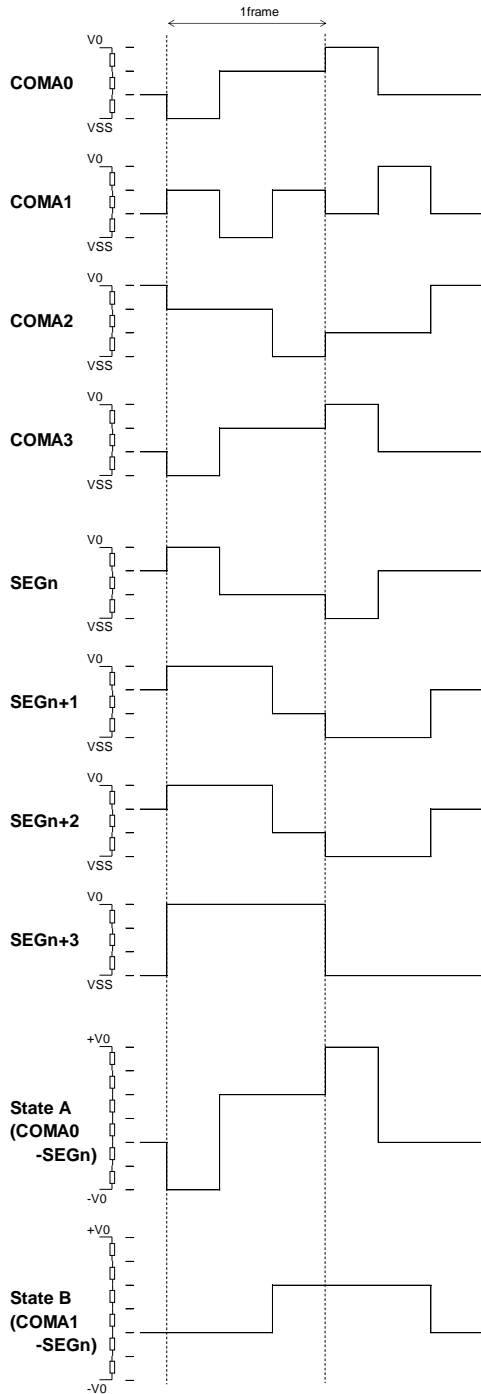
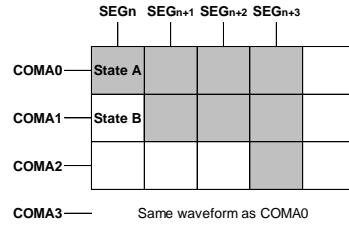

COMSET P2 = "0", Normally white type LCD case

LCD Driving Waveform - continued

1/2 Bias, 1/3 Duty Drive

Frame Inversion

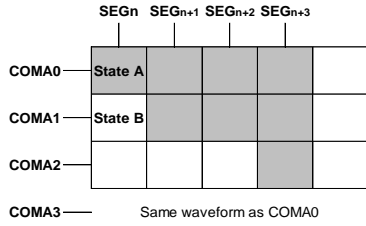

Line Inversion

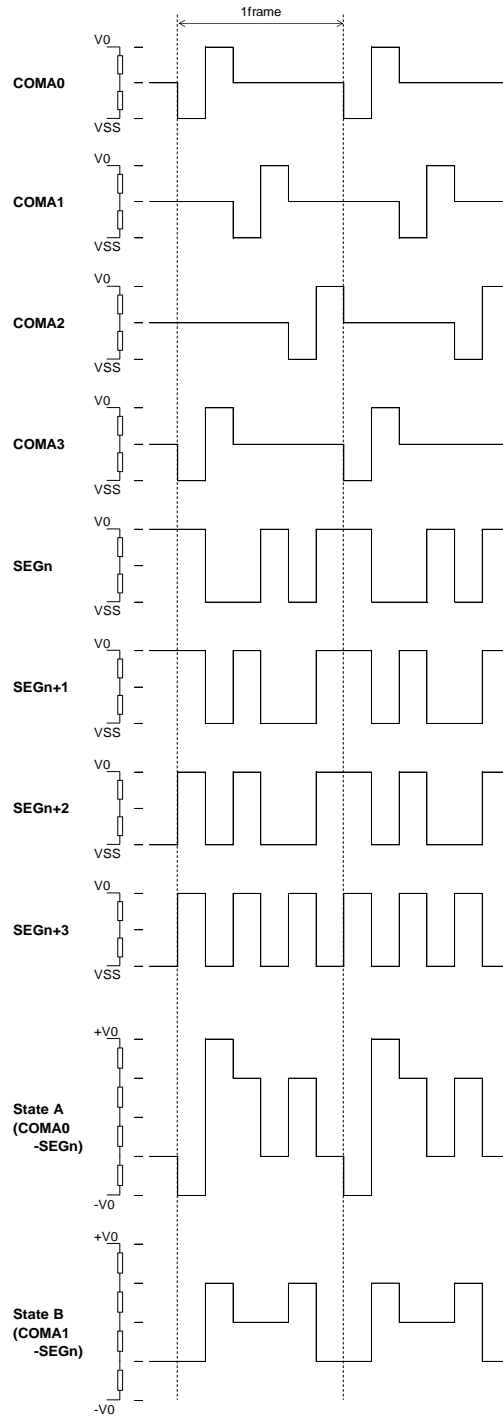
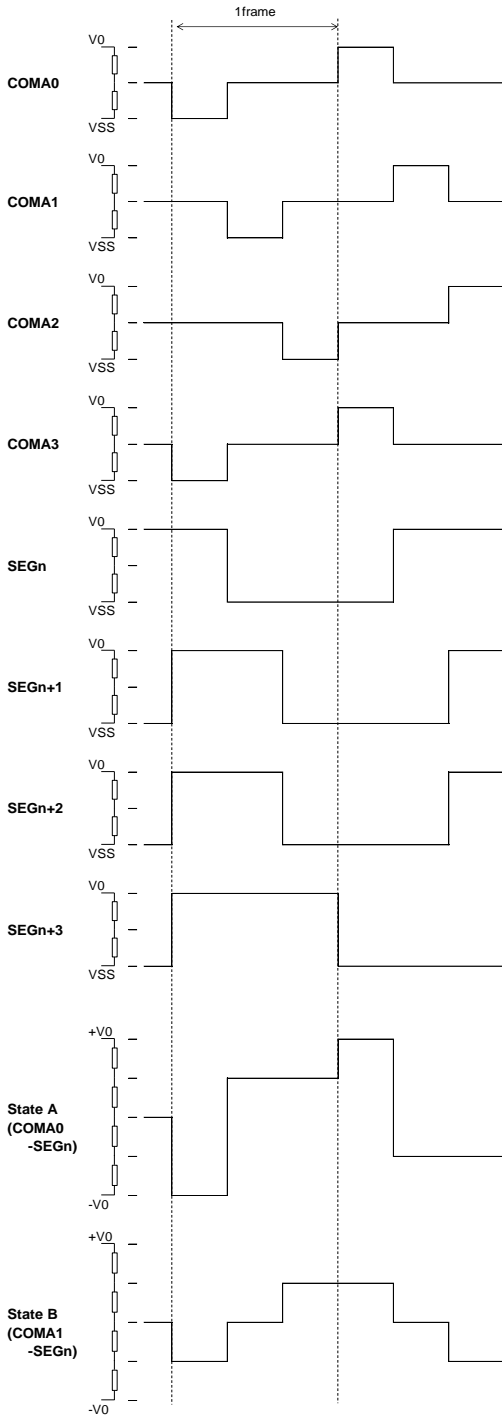
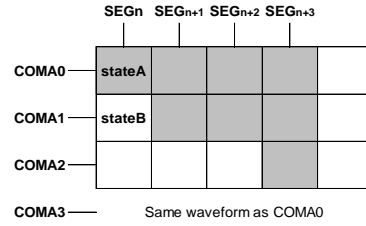

COMSET P2 = "0", Normally white type LCD case

LCD Driving Waveform - continued

1/3 Bias, 1/2 Duty Drive

Frame Inversion

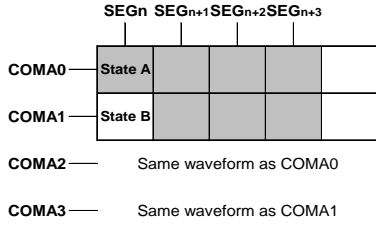

Line Inversion

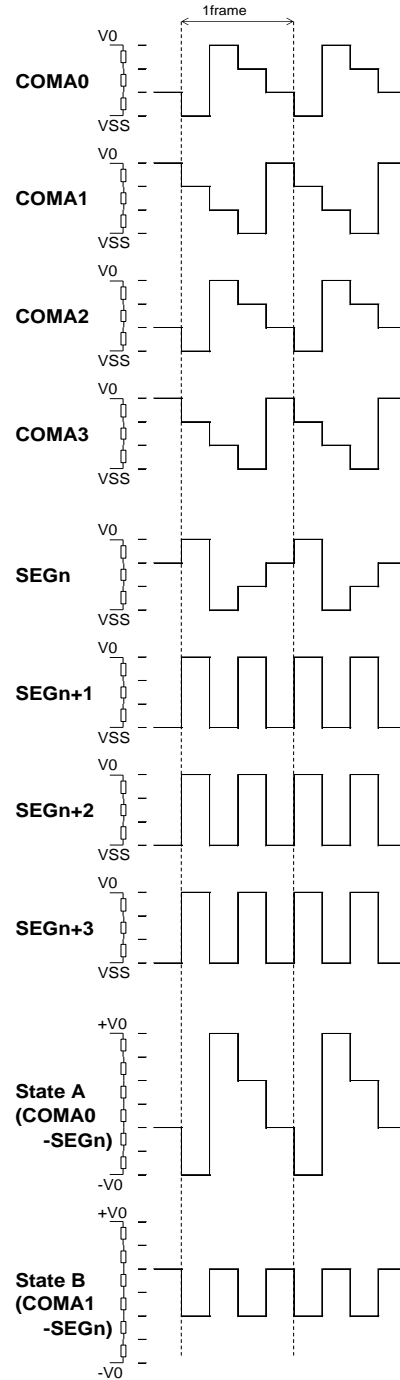
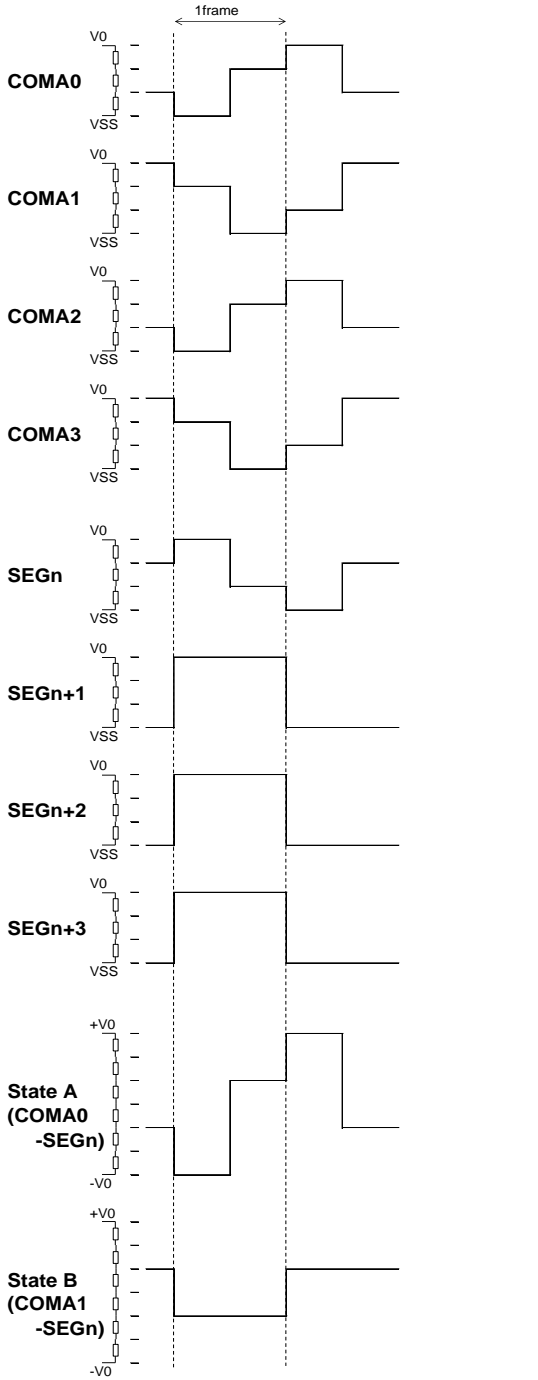
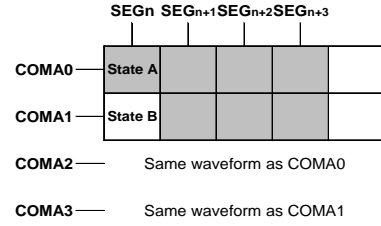

COMSET P2 = "0", Normally white type LCD case

LCD Driving Waveform - continued

1/2 Bias, 1/2 Duty Drive

Frame Inversion

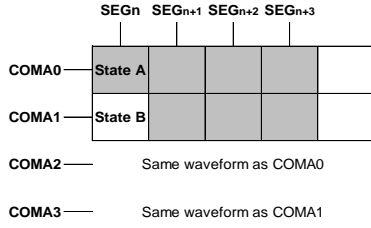

Line Inversion

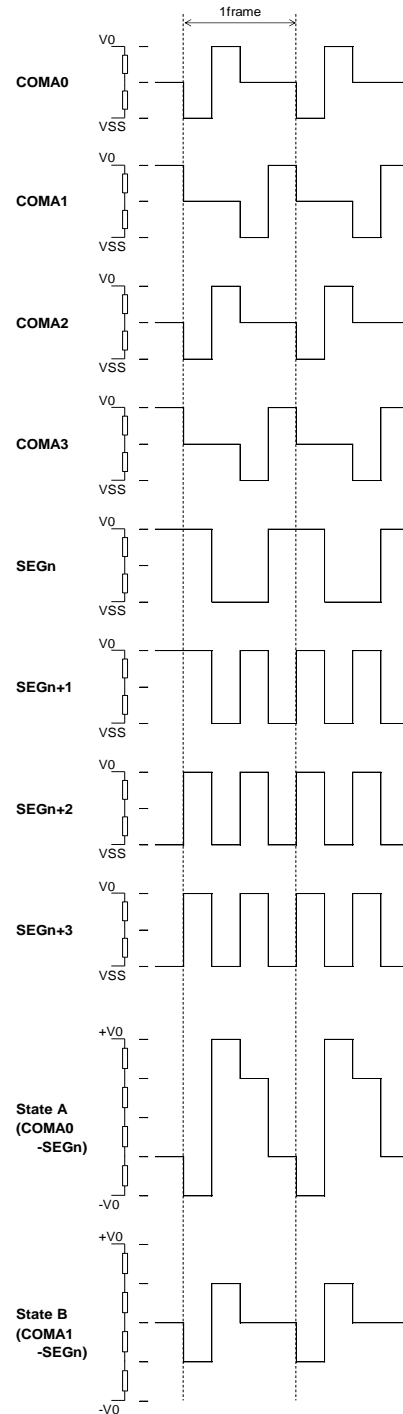
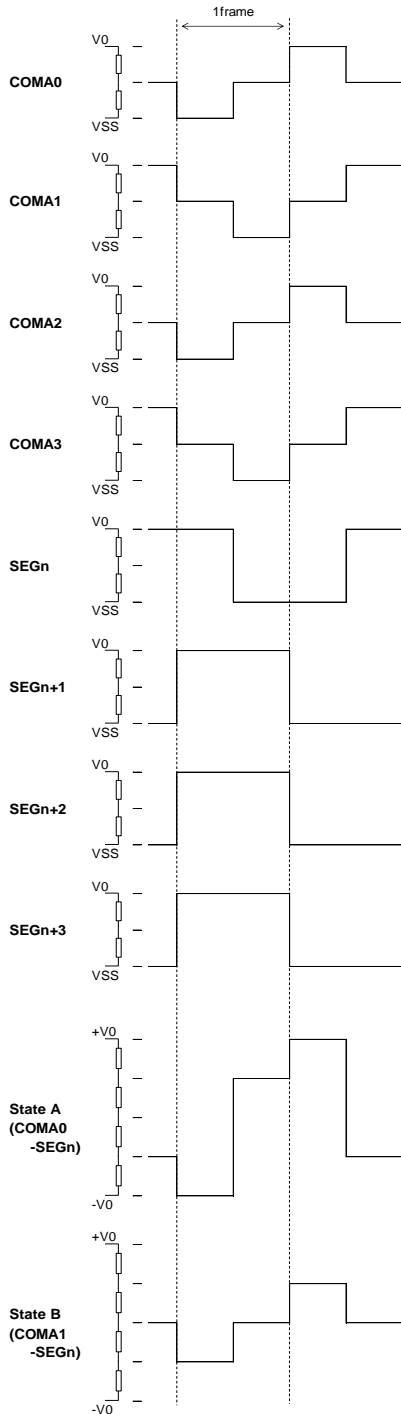
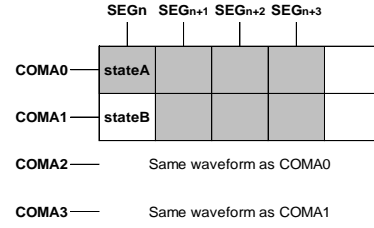

COMSET P2 = "0", Normally white type LCD case

LCD Driving Waveform - continued

Static Drive

Frame Inversion

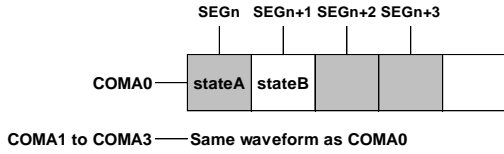

Line Inversion

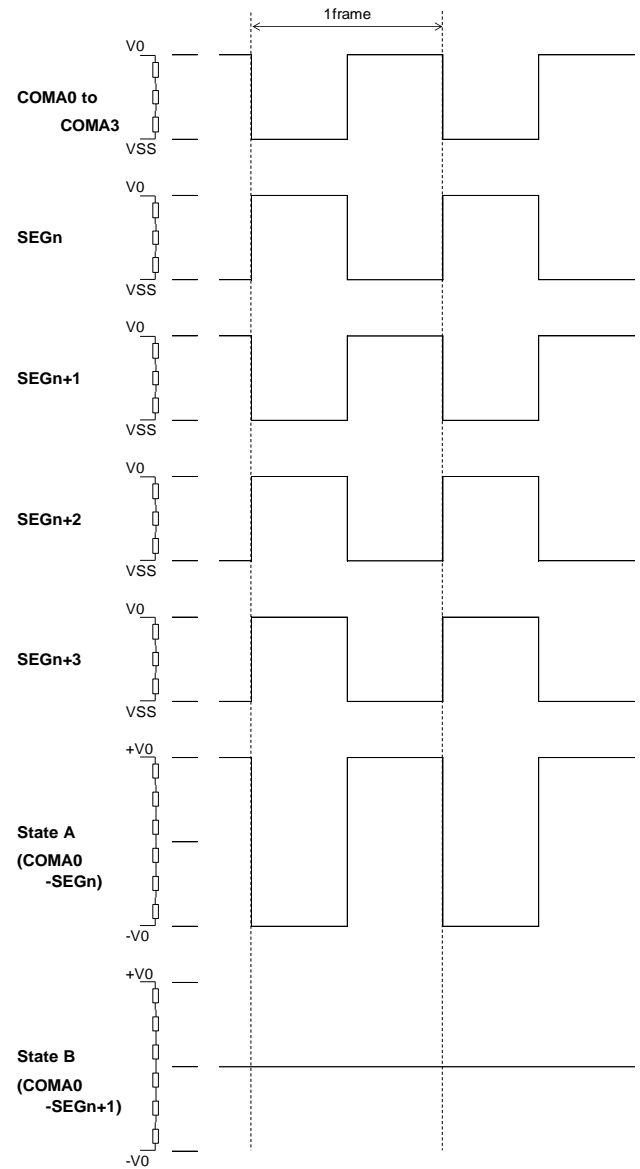
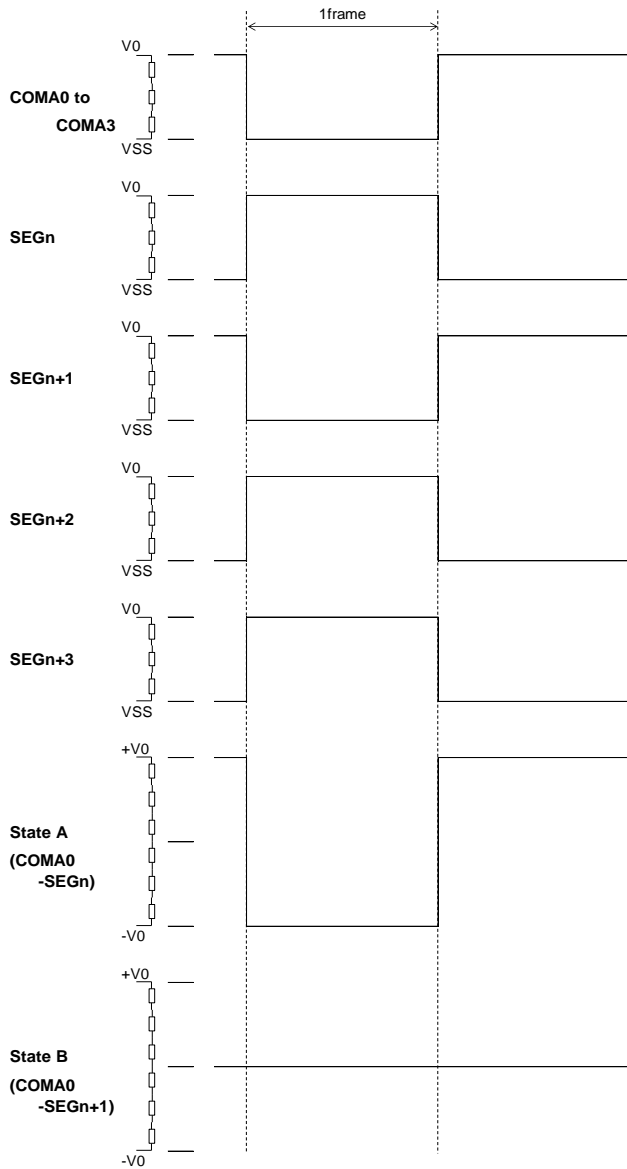
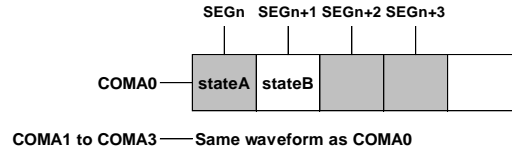

Normally white type LCD case

Example of Display Data

In case of LCD layout pattern shown in [Figure 41. Example COM Line Pattern](#) and [Figure 42. Example SEG Line Pattern](#) and DDRAM data shown in [Table 8. DDRAM Data Example](#), display pattern will be shown as in [Figure 43. Example Display Pattern](#).

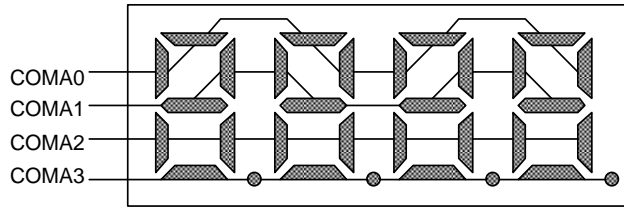

Figure 41. Example COM Line Pattern

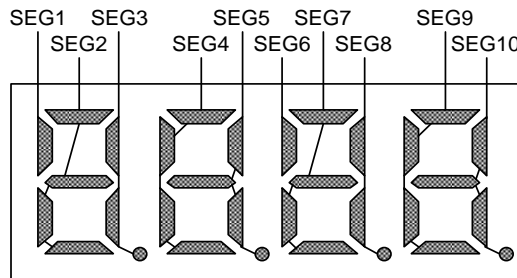

Figure 42. Example SEG Line Pattern

Table 8. DDRAM Data Example

	SEG0	SEG1	SEG2	SEG3	SEG4	SEG5	SEG6	SEG7	SEG8	SEG9	SEG10	SEG11	SEG12	SEG13	SEG14	SEG15	SEG16	SEG17	SEG18	SEG19
COMA0	0	1	0	0	0	0	1	1	0	0	1	0	0	0	0	0	0	0	0	0
COMA1	0	0	1	0	0	0	0	1	1	0	1	0	0	0	0	0	0	0	0	0
COMA2	0	0	1	1	1	1	0	0	1	0	0	0	0	0	0	0	0	0	0	0
COMA3	0	0	1	0	1	1	0	1	0	0	0	0	0	0	0	0	0	0	0	0
Address	00h	01h	02h	03h	04h	05h	06h	07h	08h	09h	0Ah	0Bh	0Ch	0Dh	0Eh	0Fh	10h	11h	12h	13h

(The COM scan order: COMSET P0 = "0")

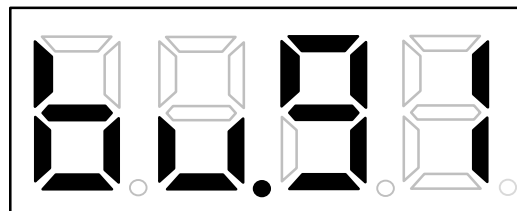
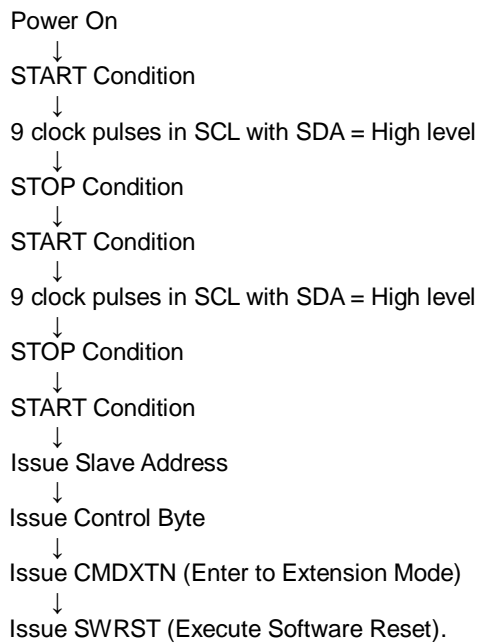

Figure 43. Example Display Pattern

Initialize Sequence

Follow the Power On sequence below to set IC to initial reset condition.



After Power On and before sending initialize sequence, each register value, DDRAM address and DDRAM data are random if POR is disabled by TR = VDD or Power On sequence cannot keep the conditions in [Figure 45. Power On / Off Waveform](#).

Start Sequence

Start Sequence Example1

No.	Input	D7	D6	D5	D4	D3	D2	D1	D0	Descriptions
1	Power On	-	-	-	-	-	-	-	-	VDD = 0 V→3.3 V ($t_R = 1$ ms), VLCD = 0 V→5.0 V
2	Wait 100 μ s	-	-	-	-	-	-	-	-	Initialize BU91R64CH-M
3	START	-	-	-	-	-	-	-	-	START Condition
4	Dummy Byte	1	1	1	1	1	1	1	1	9 clock pulses in SCL with SDA = High level
5	STOP	-	-	-	-	-	-	-	-	STOP Condition
6	START	-	-	-	-	-	-	-	-	START Condition
7	Dummy Byte	1	1	1	1	1	1	1	1	9 clock pulses in SCL with SDA = High level
8	STOP	-	-	-	-	-	-	-	-	STOP Condition
9	START	-	-	-	-	-	-	-	-	START Condition
10	Slave Address	0	1	1	1	1	1	0	0	Issue Slave Address
11	Control Byte	0	0	0	0	0	0	0	0	Issue Control Byte
12	CMDXTN	1	1	1	1	1	1	0	1	Enter to Extension Mode
13	SWRST	1	0	0	0	0	0	0	1	Software Reset
14	STOP	-	-	-	-	-	-	-	-	STOP Condition
15	START	-	-	-	-	-	-	-	-	START Condition
16	Slave Address	0	1	1	1	1	1	0	0	Issue Slave Address
17	Control Byte	0	0	0	0	0	0	0	0	Issue Control Byte
18	MODESET1	1	1	0	0	0	0	0	0	Display Off
19	CMDXTN	1	1	1	1	1	1	0	1	Enter to Extension Mode
20	MODESET2	1	0	0	1	0	0	0	0	All detections: disabled
21	MODESET3	1	0	1	0	0	0	0	0	Line Inversion, Normal Frequency Mode
22	CNTSET	1	0	1	1	0	0	0	0	V0 = 1.000 x VLCD level
23	RDCTL	1	1	0	0	0	0	0	0	Read setting (disabled)
24	COMSET	1	1	1	0	0	0	0	0	COM Set
25	CMDXTN	1	1	1	1	1	1	0	0	Enter to Normal Mode
26	FRSET	1	1	1	0	1	1	1	0	Frame frequency = 155.3 Hz
27	BLKCTL1	1	1	1	1	0	0	0	0	Blink off
28	BLKCTL2	1	1	1	1	1	0	0	0	Data write access to Normal Display Area
29	SADSET	1	1	1	0	0	0	0	0	Sub Address Set
30	ADSET	0	0	0	0	0	0	0	0	Address Set
31	STOP	-	-	-	-	-	-	-	-	STOP Condition
32	START	-	-	-	-	-	-	-	-	START Condition
33	Slave Address	0	1	1	1	1	1	0	0	Issue Slave Address
34	Control Byte	0	1	0	0	0	0	0	0	Issue Control Byte
35	Display Data	*	*	*	*	*	*	*	*	Address 00h to 01h
	Display Data	*	*	*	*	*	*	*	*	Address 02h to 03h
	:	:	:	:	:	:	:	:	:	:
	Display Data	*	*	*	*	*	*	*	*	Address 4Eh to 4Fh
36	STOP	-	-	-	-	-	-	-	-	STOP Condition
37	START	-	-	-	-	-	-	-	-	START Condition
38	Slave Address	0	1	1	1	1	1	0	0	Issue Slave Address
39	Control Byte	0	0	0	0	0	0	0	0	Issue Control Byte
40	MODESET1	1	1	0	0	1	0	0	0	Display On
41	STOP	-	-	-	-	-	-	-	-	STOP Condition

(*: don't care)

Start Sequence – continued

Start Sequence Example2

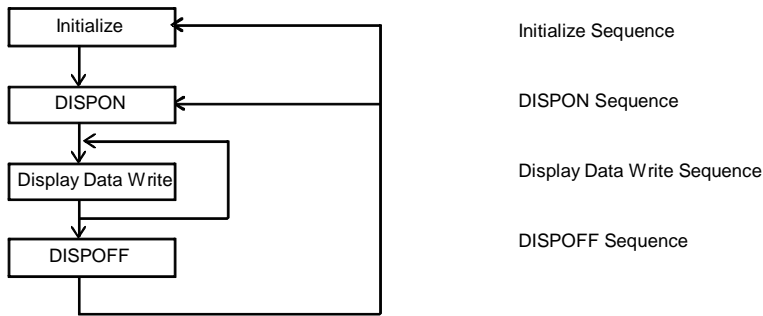

BU91R64CH-M is initialized with “Initialize Sequence”, starts to display with “DISPON Sequence”, updates Display Data with “Display Data Write Sequence” and stops the display with “DISPOFF Sequence”. Execute “DISPON Sequence” when MCU starts display again.

Initialize Sequence		Data								Description
Input	D7	D6	D5	D4	D3	D2	D1	D0		
VDD on										
VLCD on										
Wait for 100µs										
START										
Dummy Byte	1	1	1	1	1	1	1	1	Keep high in ACK bit	
STOP										
START										
Dummy Byte	1	1	1	1	1	1	1	1	Keep high in ACK bit	
STOP										
START										
Slave Address	0	1	1	1	1	1	0	0	Enter to Extension Mode Software Reset	
Control Byte	0	0	0	0	0	0	0	0		
CMDXTN	1	1	1	1	1	1	0	1		
SWRST	1	0	0	0	0	0	0	1		
STOP										
START										
Slave Address	0	1	1	1	1	1	0	0	Display Off Enter to Extension Mode All detections: disabled Inversion / FR setting Contrast Set Read setting COM Set Enter to Normal Mode Frame Frequency Blink setting Data write setting Sub Address Set Address Set	
Control Byte	0	0	0	0	0	0	0	0		
MODESET1	1	1	0	0	0	0	0	0		
CMDXTN	1	1	1	1	1	1	0	1		
MODESET2	1	0	0	1	0	0	0	0		
MODESET3	1	0	1	0	0	0	0	0		
CNTSET	1	0	1	1	0	0	0	0		
RDCTL	1	1	0	0	0	0	0	0		
COMSET	1	1	1	0	0	0	0	0		
CMDXTN	1	1	1	1	1	1	0	0		
FRSET	1	1	1	0	1	1	1	0		
BLKCTL1	1	1	1	1	0	0	0	0		
BLKCTL2	1	1	1	1	1	0	0	0		
SADSET	1	1	1	0	0	0	0	0		
ADSET	0	0	0	0	0	0	0	0		
STOP										
START										
Slave Address	0	1	1	1	1	1	0	0		
Control Byte	0	1	0	0	0	0	0	0		
Display Data	*	*	*	*	*	*	*	*		
:										
STOP										

DISPON Sequence		Data								Description
Input	D7	D6	D5	D4	D3	D2	D1	D0		
START										
Slave Address	0	1	1	1	1	1	0	0	Enter to Extension Mode All detections: disabled Inversion / FR setting Contrast Set Read setting COM Set Enter to Normal Mode Frame Frequency Blink setting Data write setting Display On	
Control Byte	0	0	0	0	0	0	0	0		
CMDXTN	1	1	1	1	1	1	0	1		
MODESET2	1	0	0	1	0	0	0	0		
MODESET3	1	0	1	0	0	0	0	0		
CNTSET	1	0	1	1	0	0	0	0		
RDCTL	1	1	0	0	0	0	0	0		
COMSET	1	1	1	0	0	0	0	0		
CMDXTN	1	1	1	1	1	1	0	0		
FRSET	1	1	1	0	1	1	1	0		
BLKCTL1	1	1	1	1	0	0	0	0		
BLKCTL2	1	1	1	1	1	0	0	0		
MODESET1	1	1	0	0	1	0	0	0		
STOP										

Display Data Write Sequence		Data								Description
Input	D7	D6	D5	D4	D3	D2	D1	D0		
START										
Slave Address	0	1	1	1	1	1	0	0	Display On Enter to Extension Mode All detections: disabled Inversion / FR setting Contrast Set Read setting COM Set Enter to Normal Mode Frame Frequency Blink setting Data write setting Sub Address Set Address Set	
Control Byte	0	0	0	0	0	0	0	0		
MODESET1	1	1	0	0	1	0	0	0		
CMDXTN	1	1	1	1	1	1	0	1		
MODESET2	1	0	0	1	0	0	0	0		
MODESET3	1	0	1	0	0	0	0	0		
CNTSET	1	0	1	1	0	0	0	0		
RDCTL	1	1	0	0	0	0	0	0		
COMSET	1	1	1	0	0	0	0	0		
CMDXTN	1	1	1	1	1	1	0	0		
FRSET	1	1	1	0	1	1	1	0		
BLKCTL1	1	1	1	1	0	0	0	0		
BLKCTL2	1	1	1	1	1	0	0	0		
SADSET	1	1	1	0	0	0	0	0		
ADSET	0	0	0	0	0	0	0	0		
STOP										
START										
Slave Address	0	1	1	1	1	1	0	0		
Control Byte	0	1	0	0	0	0	0	0		
Display Data	*	*	*	*	*	*	*	*		
:										
STOP										

DISPOFF Sequence		Data								Description
Input	D7	D6	D5	D4	D3	D2	D1	D0		
START										
Slave Address	0	1	1	1	1	1	0	0	Display Off	
Control Byte	0	0	0	0	0	0	0	0		
MODESET1	1	1	0	0	0	0	0	0		
STOP										

(*: don't care)

Abnormal operation may occur in BU91R64CH-M due to the effect of noise or other external factor. To avoid this phenomenon, it is highly recommended to input command according to sequence described above during initialization, Display On / Off and refresh of Display Data.

Cautions in Power On / Off

Please keep Power On / Off sequence as below waveform. To prevent incorrect display, malfunction and abnormal current, VDD must be turned on before VLCD in power up sequence. VDD must be turned off after VLCD in power down sequence. Please satisfies $t_1 > 0$ ns, $t_2 > 0$ ns.
 To refrain from data transmission is strongly recommended while power supply is rising up or falling down to prevent from the occurrence of disturbances on transmission and reception.

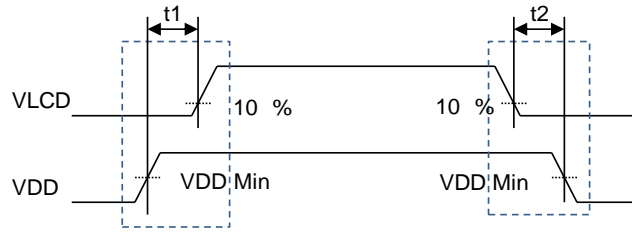

Figure 44. Recommended Power On / Off Sequence

BU91R64CH-M has “POR” (Power On Reset) circuit and Software Reset function. Keep the following recommended Power On conditions in order to power up properly.
 Set power up conditions to meet the recommended t_R , t_F , t_{OFF} , and V_{BOT} specification below in order to ensure POR operation. Set terminal TR = VSS to enable POR circuit.

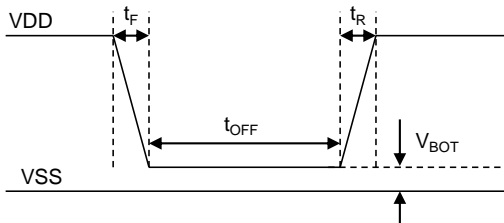

Figure 45. Power On / Off Waveform

Recommended condition of t_R , t_F , t_{OFF} , V_{BOT} ($T_a = 25$ °C)

$t_R^{(Note)}$	$t_F^{(Note)}$	$t_{OFF}^{(Note)}$	$V_{BOT}^{(Note)}$
1 ms to 500 ms	1 ms to 500 ms	Min 20 ms	Less than 0.1 V

(Note) This function is guaranteed by design, not tested in production process.

If it is difficult to keep above conditions, execute the following sequence as quickly as possible after Power On. Setting TR = VDD disables the POR circuit, in such case, execute the following sequence. Note that however it cannot accept command while supply is unstable or below the minimum supply range. Note also that software reset is not a complete alternative to POR function.

2-wire Serial Interface	3-wire Serial Interface
<p>1. Generate two dummy bytes with START and STOP Conditions SDAI must be “1” as data.</p> <p style="text-align: center;">Figure 46. Dummy Clock / STOP / START Condition</p> <p>2. Execute Software Reset as follows Send START Condition Send Slave Address (7Ch, 7Eh, 70h or 72h) Send Control Byte (00h) Send CMDXTN command (FDh) Send SWRST command (81h)</p>	<p>1. Set CSB to High level.</p> <p style="text-align: center;">Figure 47. CSB Timing</p> <p>2. Set CSB to low level, then execute Software Reset as follows: Send CMDXTN command (FDh) Send SWRST command (81h)</p>

Display Off Operation in External Clock Mode

Clock stop timing in Display Off

After receiving MODESET1 Display Off (DISPOFF), BU91R64CH-M enters to DISPOFF sequence synchronized with frame then Segment and Common terminals output VSS level.

Therefore, in External Clock Mode, it is necessary to input the external clock (minimum 26 clock pulses) based on each Frame Frequency setting after sending MODESET1 DISPOFF command.

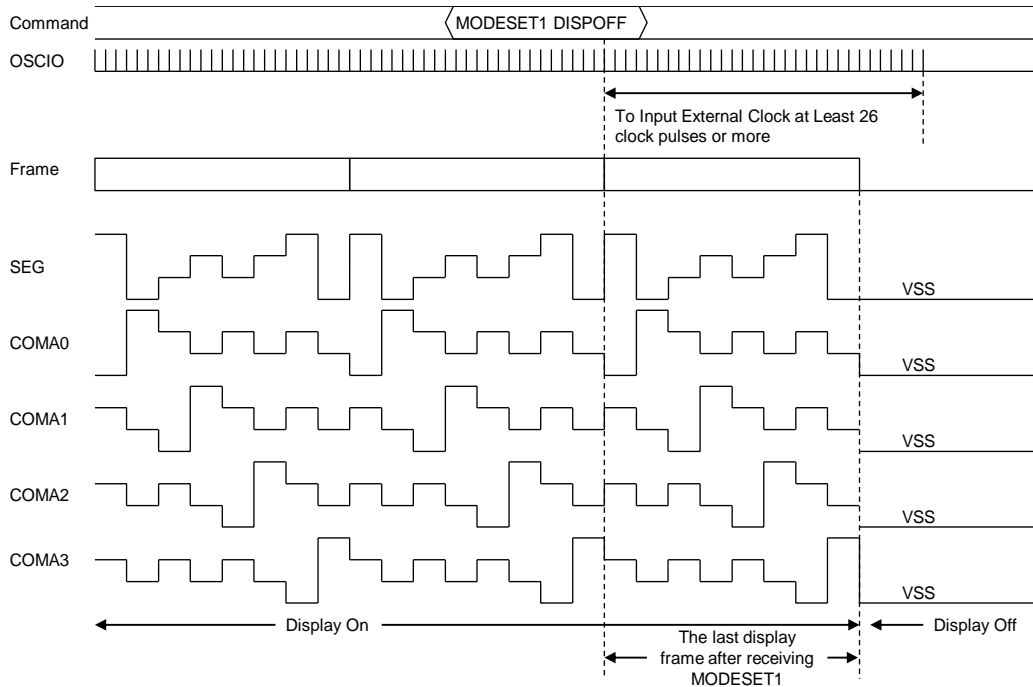

Figure 48. External Clock Stop Timing

In case of External Clock Mode, a clock signal shall be always supplied to BU91R64CH-M. Removing the clock may freeze the LCD in a DC state which is not suitable for the LCD.

In Multi-chip Structure in Internal Clock Mode

In multi-chip structure and in internal clock mode, clock signal for Slave 1 to Slave 3 display are provided by Master IC. So if Master IC receives Display Off before Slave ICs, the clock from Master IC will stop and Slave ICs hold the SEG and COM level not VSS level, then causes abnormal display. To prevent this issue, DISPOFF must be sent to Slave ICs earlier than to Master IC.

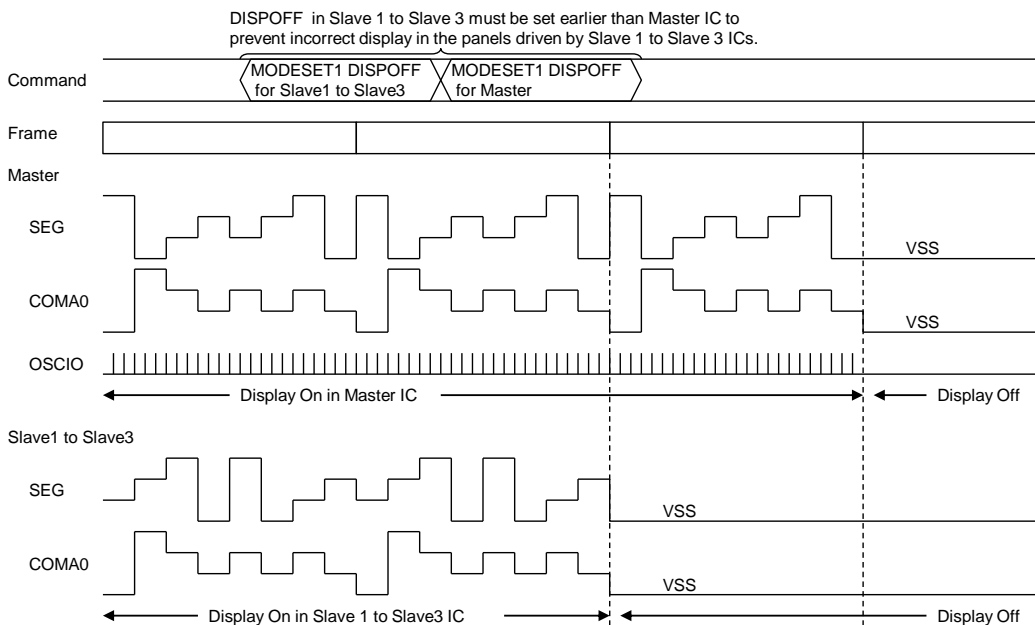

Figure 49. DISPOFF Sequence in Multi-chip Structure

Note on The Multiple Device Connection to 2-wire Serial Interface.

Do not access the other device without power supply (VDD) to the BU91R64CH-M.

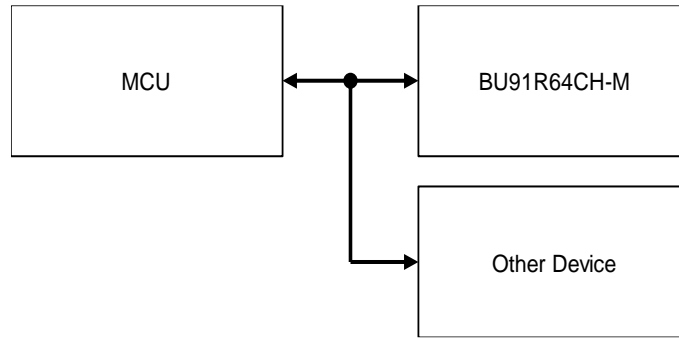

Figure 50. Example of BUS Connection

To control the slope of the falling edge, a capacitor is connected between gate and drain of a NMOS transistor as shown in the following figure. The gate is in a high-impedance state when the power supply (VDD) is not supplied.

In this condition, the gate voltage is pulled up by the current flow through the capacitance as a result of the SDAO signal's transition from low to high.

The NMOS transistor turns on and draws some current (I_{ds}) from the SDAO if the gate voltage (V_g) is higher than the threshold voltage (V_{th}).

An external resistor (R) is connected between the power line and SDAO line to keep the SDA line as logic high. But the line cannot be kept as logic high if the voltage drop ($R \cdot I_{ds}$) is large.

Apply power supply (VDD) to BU91R64CH-M when the multiple devices are on the same bus.

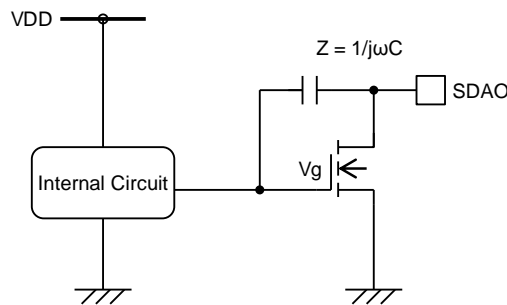

Figure 51. SDA Output Cell Structure

Note in Case that the SDA is stuck at LOW

Normally, BU91R64CH-M SDA status is controlled by MCU, so it set SDA to VSS level only in ACK timing and in output "0" case during Read Mode.

If the data line (SDAO) is stuck at LOW by BU91R64CH-M unexpectedly, MCU should send two dummy bytes with START and STOP Conditions as show in [Figure 52. Recovery Sequence from SDA Stuck](#). BU91R64CH-M will release SDAO stuck within this sequence.

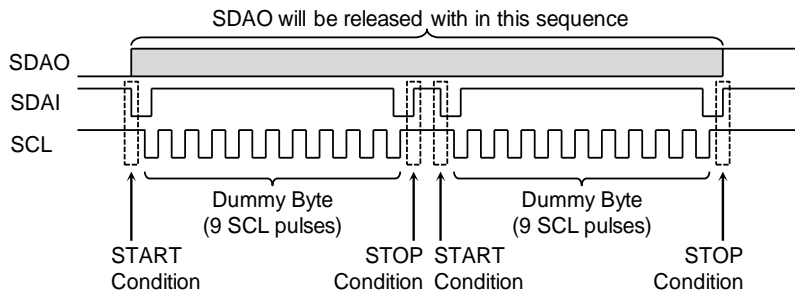

Figure 52. Recovery Sequence from SDA Stuck

Operational Notes

1. Reverse Connection of Power Supply

Connecting the power supply in reverse polarity can damage the IC. Take precautions against reverse polarity when connecting the power supply, such as mounting an external diode between the power supply and the IC's power supply pins.

2. Power Supply Lines

Design the PCB layout pattern to provide low impedance supply lines. Separate the ground and supply lines of the digital and analog blocks to prevent noise in the ground and supply lines of the digital block from affecting the analog block. Furthermore, connect a capacitor to ground at all power supply pins. Consider the effect of temperature and aging on the capacitance value when using electrolytic capacitors.

3. Ground Voltage

Ensure that no pins are at a voltage below that of the ground pin at any time, even during transient condition.

4. Ground Wiring Pattern

When using both small-signal and large-current ground traces, the two ground traces should be routed separately but connected to a single ground at the reference point of the application board to avoid fluctuations in the small-signal ground caused by large currents. Also ensure that the ground traces of external components do not cause variations on the ground voltage. The ground lines must be as short and thick as possible to reduce line impedance.

5. Recommended Operating Conditions

The function and operation of the IC are guaranteed within the range specified by the recommended operating conditions. The characteristic values are guaranteed only under the conditions of each item specified by the electrical characteristics.

6. Inrush Current

When power is first supplied to the IC, it is possible that the internal logic may be unstable and inrush current may flow instantaneously due to the internal powering sequence and delays, especially if the IC has more than one power supply. Therefore, give special consideration to power coupling capacitance, power wiring, width of ground wiring, and routing of connections.

7. Testing on Application Boards

When testing the IC on an application board, connecting a capacitor directly to a low-impedance output pin may subject the IC to stress. Always discharge capacitors completely after each process or step. The IC's power supply should always be turned off completely before connecting or removing it from the test setup during the inspection process. To prevent damage from static discharge, ground the IC during assembly and use similar precautions during transport and storage.

8. Inter-pin Short and Mounting Errors

Ensure that the direction and position are correct when mounting the IC on the PCB. Incorrect mounting may result in damaging the IC. Avoid nearby pins being shorted to each other especially to ground, power supply and output pin. Inter-pin shorts could be due to many reasons such as metal particles, water droplets (in very humid environment) and unintentional solder bridge deposited in between pins during assembly to name a few.

9. Unused Input Pins

Input pins of an IC are often connected to the gate of a MOS transistor. The gate has extremely high impedance and extremely low capacitance. If left unconnected, the electric field from the outside can easily charge it. The small charge acquired in this way is enough to produce a significant effect on the conduction through the transistor and cause unexpected operation of the IC. So unless otherwise specified, unused input pins should be connected to the power supply or ground line.

10. Regarding the Input Pin of the IC

In the construction of this IC, P-N junctions are inevitably formed creating parasitic diodes or transistors. The operation of these parasitic elements can result in mutual interference among circuits, operational faults, or physical damage. Therefore, conditions which cause these parasitic elements to operate, such as applying a voltage to an input pin lower than the ground voltage should be avoided. Furthermore, do not apply a voltage to the input pins when no power supply voltage is applied to the IC. Even if the power supply voltage is applied, make sure that the input pins have voltages within the values specified in the electrical characteristics of this IC.

11. Ceramic Capacitor

When using a ceramic capacitor, determine a capacitance value considering the change of capacitance with temperature and the decrease in nominal capacitance due to DC bias and others.

Operational Notes – continued**12. Disturbance Light**

In a device where a portion of silicon is exposed to light such as in a WL-CSP and chip products, IC characteristics may be affected due to photoelectric effect. For this reason, it is recommended to come up with countermeasures that will prevent the chip from being exposed to light.

Ordering Information

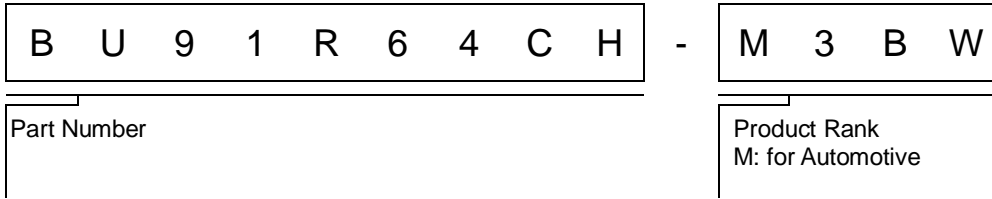

Minimum Order Quantity (MOQ)

Orderable Part Number	Minimum Order Quantity
BU91R64CH-M3BW	900 pcs

Marking Diagram

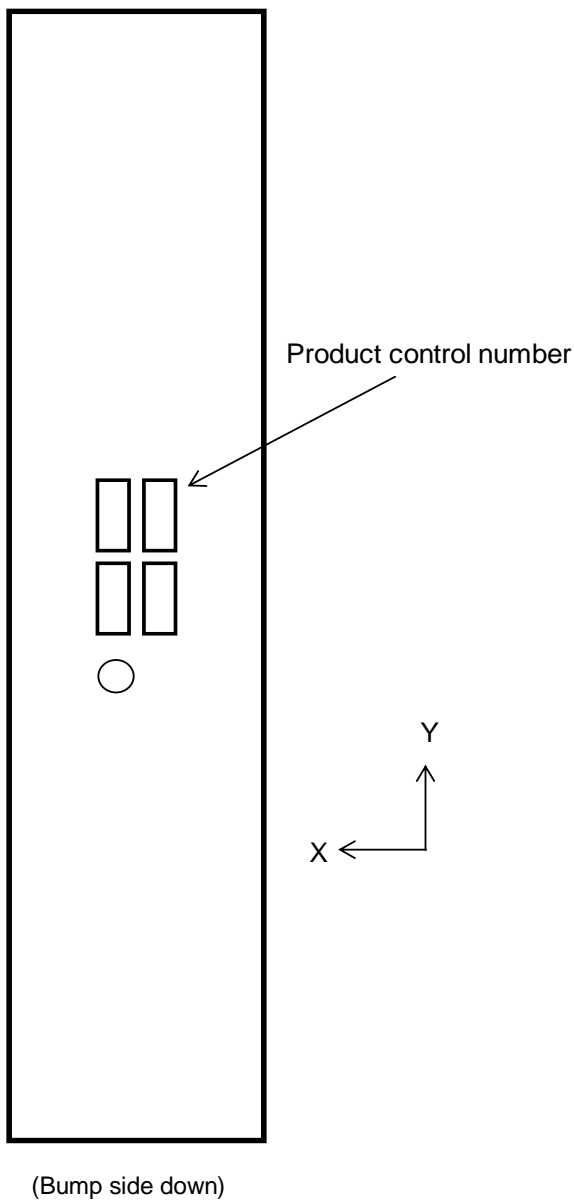

Refer to [PAD Arrangement](#) for the definition of X/Y coordinates.

Packing Quantity

Packing QTY. (Standard QTY)	Tray:	90	pcs / tray
	Block:	450	pcs / block (1 block = 5 trays)
	Vacuum Pack:	450	pcs / vacuum pack (1 vacuum pack = 1 blocks)
	Inner Box	900	pcs / inner box (1 inner box = 2 vacuum packs)
	Outer Box	1,800	pcs / outer box (1 outer box = 2 inner boxes)

Pellet Drawing

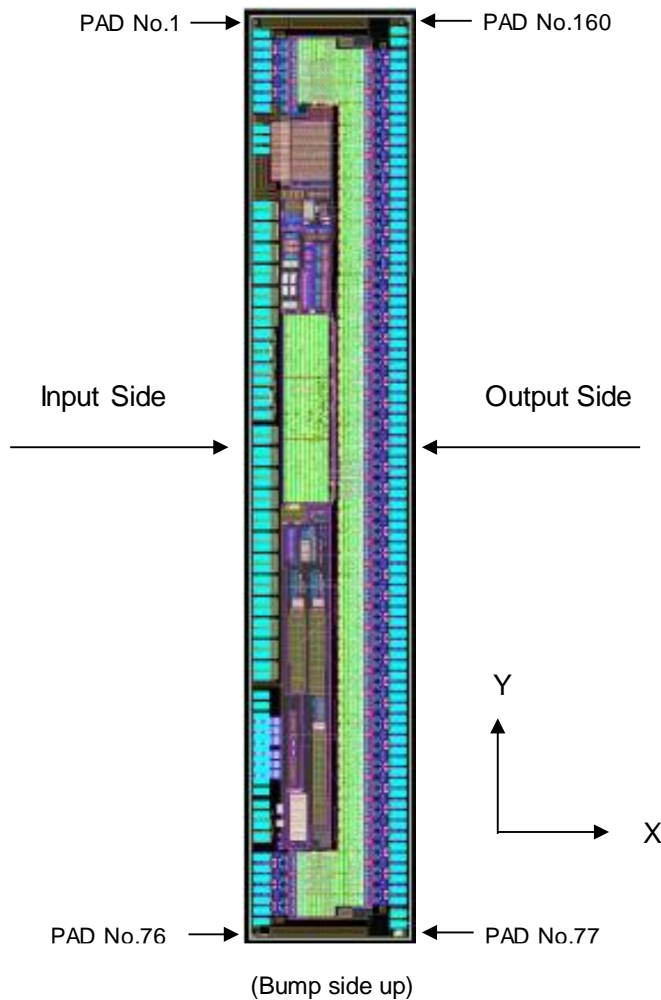

Refer to [PAD Arrangement](#) for the definition of X/Y coordinates.

Package Condition

Products should be aligned to the same direction with Bump side up.
 "Chamfering" side is aligned with X/Y direction of the chip as shown in the following drawing.

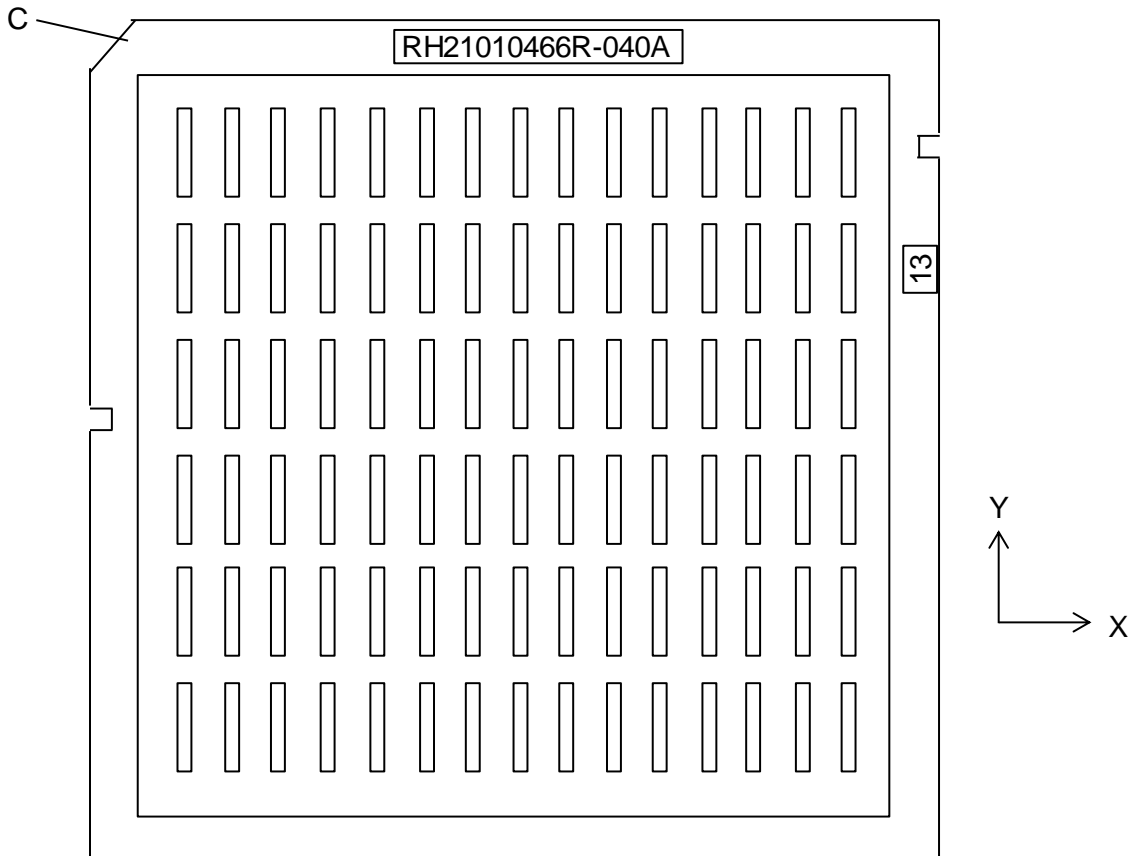

Refer to [PAD Arrangement](#) for the definition of X/Y coordinates.

Physical Dimension Tray Information

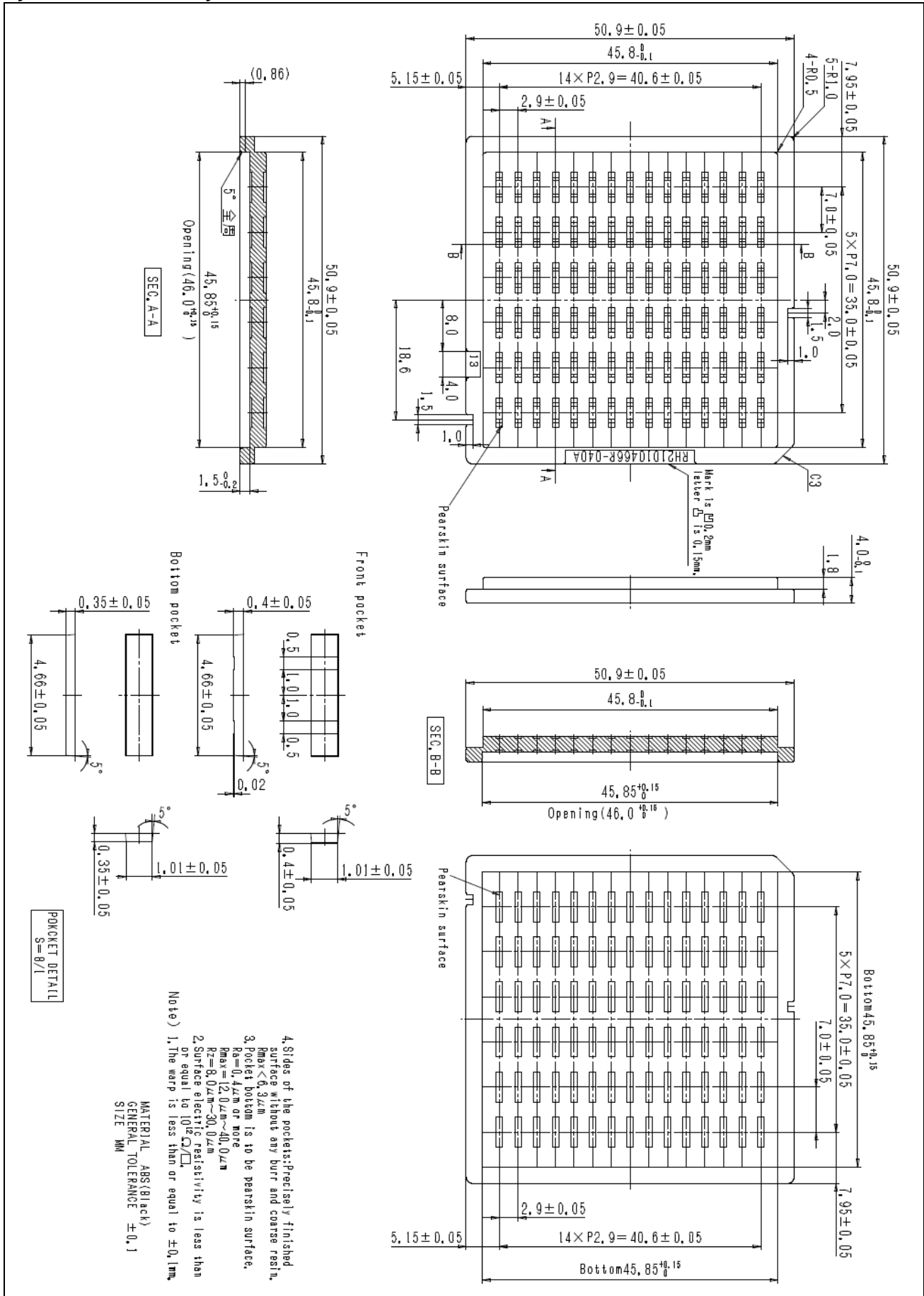

Revision History

Data	Revision	Changes
18.May. 2018	001	New Release
13.Sep. 2019	002	Updating Minimum Order Quantity and Packing Quantity Minor modifications by formality check
08.Jan. 2020	003	Updating Minimum Order Quantity and Packing Quantity Minor modifications by formality check

Notice

Precaution on using ROHM Products

1. If you intend to use our Products in devices requiring extremely high reliability (such as medical equipment ^(Note 1), aircraft/spacecraft, nuclear power controllers, etc.) and whose malfunction or failure may cause loss of human life, bodily injury or serious damage to property ("Specific Applications"), please consult with the ROHM sales representative in advance. Unless otherwise agreed in writing by ROHM in advance, ROHM shall not be in any way responsible or liable for any damages, expenses or losses incurred by you or third parties arising from the use of any ROHM's Products for Specific Applications.

(Note1) Medical Equipment Classification of the Specific Applications

JAPAN	USA	EU	CHINA
CLASS III	CLASS III	CLASS II b	CLASS III
CLASS IV		CLASS III	

2. ROHM designs and manufactures its Products subject to strict quality control system. However, semiconductor products can fail or malfunction at a certain rate. Please be sure to implement, at your own responsibilities, adequate safety measures including but not limited to fail-safe design against the physical injury, damage to any property, which a failure or malfunction of our Products may cause. The following are examples of safety measures:
 - [a] Installation of protection circuits or other protective devices to improve system safety
 - [b] Installation of redundant circuits to reduce the impact of single or multiple circuit failure
3. Our Products are not designed under any special or extraordinary environments or conditions, as exemplified below. Accordingly, ROHM shall not be in any way responsible or liable for any damages, expenses or losses arising from the use of any ROHM's Products under any special or extraordinary environments or conditions. If you intend to use our Products under any special or extraordinary environments or conditions (as exemplified below), your independent verification and confirmation of product performance, reliability, etc. prior to use, must be necessary:
 - [a] Use of our Products in any types of liquid, including water, oils, chemicals, and organic solvents
 - [b] Use of our Products outdoors or in places where the Products are exposed to direct sunlight or dust
 - [c] Use of our Products in places where the Products are exposed to sea wind or corrosive gases, including Cl₂, H₂S, NH₃, SO₂, and NO₂
 - [d] Use of our Products in places where the Products are exposed to static electricity or electromagnetic waves
 - [e] Use of our Products in proximity to heat-producing components, plastic cords, or other flammable items
 - [f] Sealing or coating our Products with resin or other coating materials
 - [g] Use of our Products without cleaning residue of flux (Exclude cases where no-clean type fluxes is used. However, recommend sufficiently about the residue.); or Washing our Products by using water or water-soluble cleaning agents for cleaning residue after soldering
 - [h] Use of the Products in places subject to dew condensation
4. The Products are not subject to radiation-proof design.
5. Please verify and confirm characteristics of the final or mounted products in using the Products.
6. In particular, if a transient load (a large amount of load applied in a short period of time, such as pulse, is applied, confirmation of performance characteristics after on-board mounting is strongly recommended. Avoid applying power exceeding normal rated power; exceeding the power rating under steady-state loading condition may negatively affect product performance and reliability.
7. De-rate Power Dissipation depending on ambient temperature. When used in sealed area, confirm that it is the use in the range that does not exceed the maximum junction temperature.
8. Confirm that operation temperature is within the specified range described in the product specification.
9. ROHM shall not be in any way responsible or liable for failure induced under deviant condition from what is defined in this document.

Precaution for Mounting / Circuit board design

1. When a highly active halogenous (chlorine, bromine, etc.) flux is used, the residue of flux may negatively affect product performance and reliability.
2. In principle, the reflow soldering method must be used on a surface-mount products, the flow soldering method must be used on a through hole mount products. If the flow soldering method is preferred on a surface-mount products, please consult with the ROHM representative in advance.

For details, please refer to ROHM Mounting specification

Precautions Regarding Application Examples and External Circuits

1. If change is made to the constant of an external circuit, please allow a sufficient margin considering variations of the characteristics of the Products and external components, including transient characteristics, as well as static characteristics.
2. You agree that application notes, reference designs, and associated data and information contained in this document are presented only as guidance for Products use. Therefore, in case you use such information, you are solely responsible for it and you must exercise your own independent verification and judgment in the use of such information contained in this document. ROHM shall not be in any way responsible or liable for any damages, expenses or losses incurred by you or third parties arising from the use of such information.

Precaution for Electrostatic

This Product is electrostatic sensitive product, which may be damaged due to electrostatic discharge. Please take proper caution in your manufacturing process and storage so that voltage exceeding the Products maximum rating will not be applied to Products. Please take special care under dry condition (e.g. Grounding of human body / equipment / solder iron, isolation from charged objects, setting of Ionizer, friction prevention and temperature / humidity control).

Precaution for Storage / Transportation

1. Product performance and soldered connections may deteriorate if the Products are stored in the places where:
 - [a] the Products are exposed to sea winds or corrosive gases, including Cl₂, H₂S, NH₃, SO₂, and NO₂
 - [b] the temperature or humidity exceeds those recommended by ROHM
 - [c] the Products are exposed to direct sunshine or condensation
 - [d] the Products are exposed to high Electrostatic
2. Even under ROHM recommended storage condition, solderability of products out of recommended storage time period may be degraded. It is strongly recommended to confirm solderability before using Products of which storage time is exceeding the recommended storage time period.
3. Store / transport cartons in the correct direction, which is indicated on a carton with a symbol. Otherwise bent leads may occur due to excessive stress applied when dropping of a carton.
4. Use Products within the specified time after opening a humidity barrier bag. Baking is required before using Products of which storage time is exceeding the recommended storage time period.

Precaution for Product Label

A two-dimensional barcode printed on ROHM Products label is for ROHM's internal use only.

Precaution for Disposition

When disposing Products please dispose them properly using an authorized industry waste company.

Precaution for Foreign Exchange and Foreign Trade act

Since concerned goods might be fallen under listed items of export control prescribed by Foreign exchange and Foreign trade act, please consult with ROHM in case of export.

Precaution Regarding Intellectual Property Rights

1. All information and data including but not limited to application example contained in this document is for reference only. ROHM does not warrant that foregoing information or data will not infringe any intellectual property rights or any other rights of any third party regarding such information or data.
2. ROHM shall not have any obligations where the claims, actions or demands arising from the combination of the Products with other articles such as components, circuits, systems or external equipment (including software).
3. No license, expressly or implied, is granted hereby under any intellectual property rights or other rights of ROHM or any third parties with respect to the Products or the information contained in this document. Provided, however, that ROHM will not assert its intellectual property rights or other rights against you or your customers to the extent necessary to manufacture or sell products containing the Products, subject to the terms and conditions herein.

Other Precaution

1. This document may not be reprinted or reproduced, in whole or in part, without prior written consent of ROHM.
2. The Products may not be disassembled, converted, modified, reproduced or otherwise changed without prior written consent of ROHM.
3. In no event shall you use in any way whatsoever the Products and the related technical information contained in the Products or this document for any military purposes, including but not limited to, the development of mass-destruction weapons.
4. The proper names of companies or products described in this document are trademarks or registered trademarks of ROHM, its affiliated companies or third parties.

General Precaution

1. Before you use our Products, you are requested to carefully read this document and fully understand its contents. ROHM shall not be in any way responsible or liable for failure, malfunction or accident arising from the use of any ROHM's Products against warning, caution or note contained in this document.
2. All information contained in this document is current as of the issuing date and subject to change without any prior notice. Before purchasing or using ROHM's Products, please confirm the latest information with a ROHM sales representative.
3. The information contained in this document is provided on an "as is" basis and ROHM does not warrant that all information contained in this document is accurate and/or error-free. ROHM shall not be in any way responsible or liable for any damages, expenses or losses incurred by you or third parties resulting from inaccuracy or errors of or concerning such information.