

AC/DC Converter Controller

Application Information

IC Product Name	BM2P0363F
Control Method	PWM
Input	85 Vac to 264 Vac
Output	20.6V 0.3A
Type	Non- Isolation
Document Number	66AN140E
Revision	001

Reference Circuit

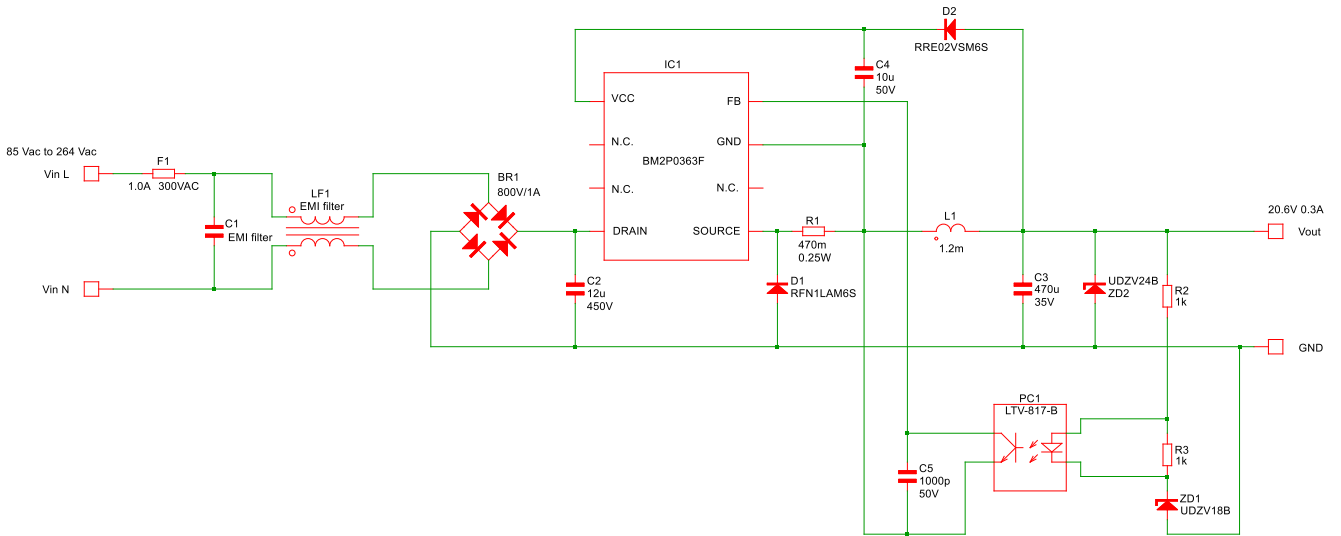

Fig1. Reference Circuit

Bill of Materials

Item	Specification	Parts name	Manufacture
IC1		BM2P0363F	Rohm
BR1	800V/1A		
C1	EMI filter	X-Capacitor	
C2	12 μ F/450V		
C3	470 μ F/35V		
C4	10 μ F/50V		
C5	1000pF/50V		
D1	600V/0.8A	RFN1LAM6S	Rohm
D2	600V/0.2A	RRE02VSM6S	Rohm
F1	1.0A/300VAC		
L1※	1.2mH/0.8A		
LF1	EMI filter		
PC1		LTV-817-B	
R1	470m Ω /0.25W		
R2	1k Ω	MCR03EZPFX1001	Rohm
R3	1k Ω	MCR03EZPFX1001	Rohm
ZD1	18V/0.2W	UDZV18B	Rohm
ZD2	24V/0.2W	UDZV24B	Rohm

※コイルは閉磁型のものを選んでください。

Use a shield coil.

Fig2. Bill of Materials

Typical Characteristics

	85Vac	100Vac	230Vac	264Vac
0A	20.63V	20.62V	20.62V	20.63V
0.005A	20.60V	20.59V	20.61V	20.60V
0.01A	20.60V	20.61V	20.61V	20.62V
0.05A	20.62V	20.62V	20.61V	20.61V
0.1A	20.62V	20.63V	20.64V	20.65V
0.2A	20.64V	20.64V	20.63V	20.63V
0.3A	20.62V	20.62V	20.62V	20.62V

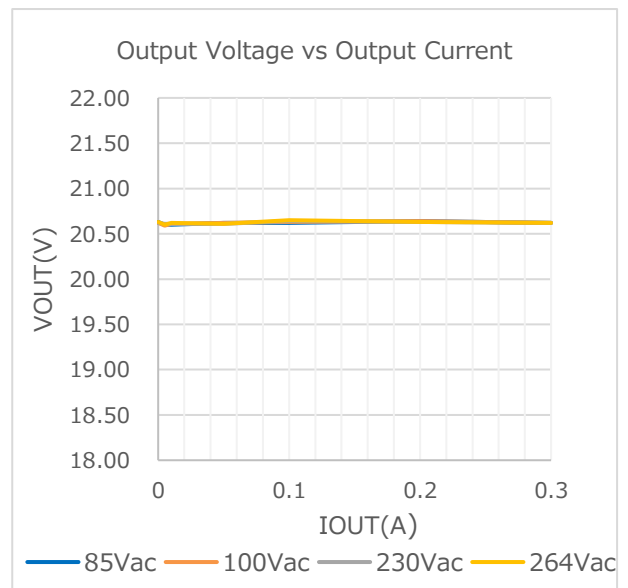

Fig3. Output Voltage vs Output Current

	85Vac	100Vac	230Vac	264Vac
0.005A	65.5%	65.4%	61.7%	60.4%
0.01A	74.9%	74.7%	70.8%	69.4%
0.05A	86.5%	86.3%	82.6%	81.2%
0.1A	87.6%	87.6%	85.7%	84.9%
0.2A	87.7%	87.8%	86.9%	86.4%
0.3A	87.2%	87.2%	86.9%	86.6%

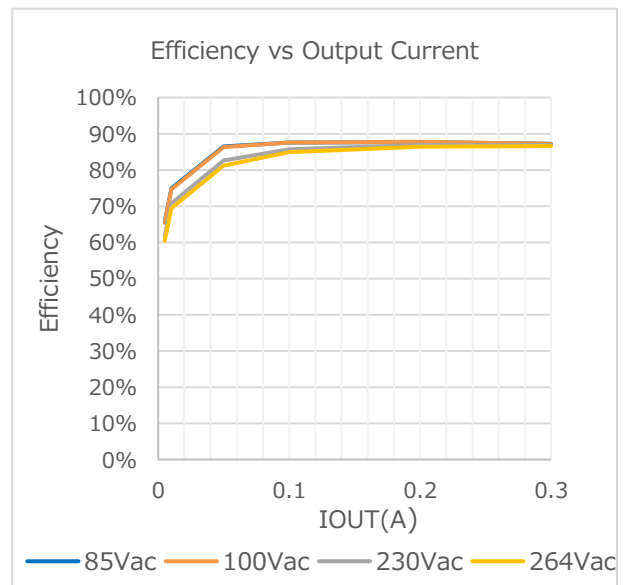

Fig4. Efficiency vs Output Current

Revision History

Date	Revision	Changes
19.Feb.2024	001	New Release

Notice

- 1) The information contained in this document is intended to introduce ROHM Group (hereafter referred to as ROHM) products. When using ROHM products, please verify the latest specifications or datasheets before use.
- 2) ROHM products are designed and manufactured for use in general electronic equipment and applications (such as Audio Visual equipment, Office Automation equipment, telecommunication equipment, home appliances, amusement devices, etc.) or specified in the datasheets. Therefore, please contact the ROHM sales representative before using ROHM products in equipment or devices requiring extremely high reliability and whose failure or malfunction may cause danger or injury to human life or body or other serious damage (such as medical equipment, transportation, traffic, aircraft, spacecraft, nuclear power controllers, fuel control, automotive equipment including car accessories, etc. hereafter referred to as Specific Applications). Unless otherwise agreed in writing by ROHM in advance, ROHM shall not be in any way responsible or liable for any damages, expenses, or losses incurred by you or third parties arising from the use of ROHM Products for Specific Applications.
- 3) Electronic components, including semiconductors, can fail or malfunction at a certain rate. Please be sure to implement, at your own responsibilities, adequate safety measures including but not limited to fail-safe design against physical injury, and damage to any property, which a failure or malfunction of products may cause.
- 4) The information contained in this document, including application circuit examples and their constants, is intended to explain the standard operation and usage of ROHM products, and is not intended to guarantee, either explicitly or implicitly, the operation of the product in the actual equipment it will be used. As a result, you are solely responsible for it, and you must exercise your own independent verification and judgment in the use of such information contained in this document. ROHM shall not be in any way responsible or liable for any damages, expenses, or losses incurred by you or third parties arising from the use of such information.
- 5) When exporting ROHM products or technologies described in this document to other countries, you must abide by the procedures and provisions stipulated in all applicable export laws and regulations, such as the Foreign Exchange and Foreign Trade Act and the US Export Administration Regulations, and follow the necessary procedures in accordance with these provisions.
- 6) The technical information and data described in this document, including typical application circuits, are examples only and are not intended to guarantee to be free from infringement of third parties intellectual property or other rights. ROHM does not grant any license, express or implied, to implement, use, or exploit any intellectual property or other rights owned or controlled by ROHM or any third parties with respect to the information contained herein.
- 7) No part of this document may be reprinted or reproduced in any form by any means without the prior written consent of ROHM.
- 8) All information contained in this document is current as of the date of publication and subject to change without notice. Before purchasing or using ROHM products, please confirm the latest information with the ROHM sales representative.
- 9) ROHM does not warrant that the information contained herein is error-free. ROHM shall not be in any way responsible or liable for any damages, expenses, or losses incurred by you or third parties resulting from errors contained in this document.



Thank you for your accessing to ROHM product informations.
More detail product informations and catalogs are available, please contact us.

ROHM Customer Support System

<https://www.rohm.com/contactus>