

Secondary Buck DC/DC Converter

Single Synchronous Buck DC/DC Converter For Automotive BD9S300MUF-C Evaluation Board

BD9S300MUF-TSB-001 (2.7V to 5.5V Input, 1.2V, 3A Output)

Introduction

This user's guide will provide the necessary steps to operate the Evaluation Board of ROHM's BD9S300MUF-C Buck DC/DC converter. This includes the external parts, operating procedures and application data.

Description

This Evaluation Board was developed for ROHM's single Synchronous buck DC/DC converter BD9S300MUF-C. It is a synchronous buck DC/DC converter with built-in low On Resistance power MOSFETs. The BD9S300MUF-C accepts a power supply input range of 2.7V to 5.5V and generates a maximum output current of 3A. The SLLM™ control provides excellent efficiency characteristics in light-load conditions which make the product ideal for reducing standby power consumption of equipment. BD9S300MUF-C is a current mode control DC/DC Converter and features high-speed transient response.

Application

- Automotive Equipment
- Other Electronic Equipment

Recommended Operating Conditions

Table 1. Recommended Operating Conditions

| Parameter | Min | Typ | Max | Units | Conditions |
|---|-----|------|----------------------|-------|-----------------------------|
| Input Voltage | 2.7 | - | 5.5 | V | |
| Output Voltage for BD9S300MUF-C (Note1) | 0.8 | - | $P_{VIN} \times 0.8$ | V | |
| Output Current Range | - | - | 3.0 | A | |
| Switching Frequency | - | 2.2 | - | MHz | |
| Maximum Efficiency (Vo=3.3V) | - | 92.1 | - | % | VIN=5.0V, Io=1.0A, Ta=25°C |
| Maximum Efficiency (Vo=1.0V) | - | 82.1 | - | % | VIN=3.3V, Io=0.65A, Ta=25°C |

(Note 1) Although the minimum output voltage is configurable up to 0.8 V, it may be limited by the SW min ON pulse width. SW Minimum ON Time that BD9S300MUF-C can output stably in the entire load range is 95ns. Use the value to calculate the

input and output conditions that satisfy the equation of $95[\text{ns}] \leq \frac{V_{out}}{V_{IN} \times f_{SW}}$

Evaluation Board

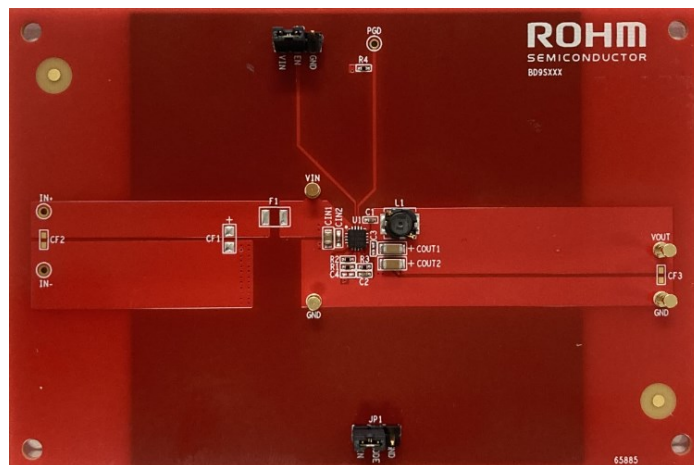

Figure 3. Evaluation Board Top View

Evaluation Board Schematic

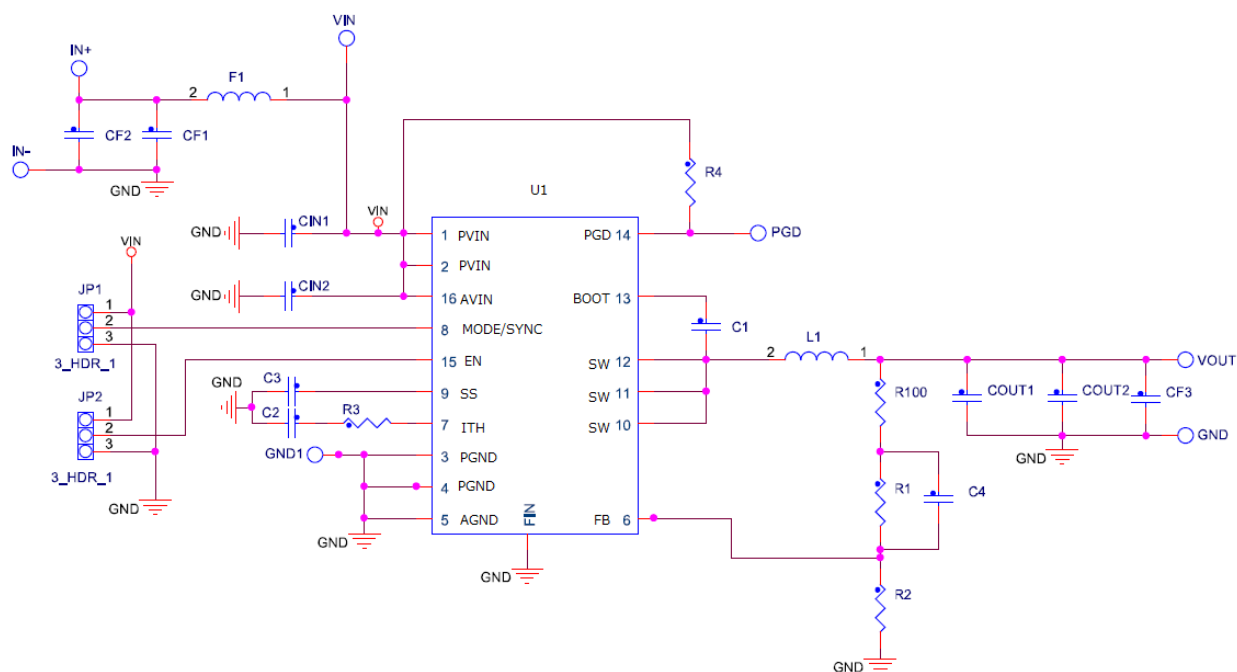

Figure 4. Circuit Diagram

Operating Procedure

1. Turn off EN and connect the GND terminal of the power supply to the GND terminal of Evaluation Board.
2. Connect power supply to the VIN terminal of the Evaluation Board.
3. Connect the load to the Evaluation Board's VOUT and GND terminals. When using an electronic load, connect with the load turned off.
4. Connect a voltmeter to the Evaluation Board's VOUT and GND terminals.
5. Turn on the Power supply of VIN. Turn ON the switch of EN terminal.
6. Make sure that the voltmeter is set to measure voltage.
7. Turn on the electronic load.

(Caution) This Evaluation Board does not support hot plug. Do not perform hot plug test.

(Note) If EN=High (EN short to VIN) before Power ON, the turn ON and turn OFF is controlled by VIN only.

Pin Configuration

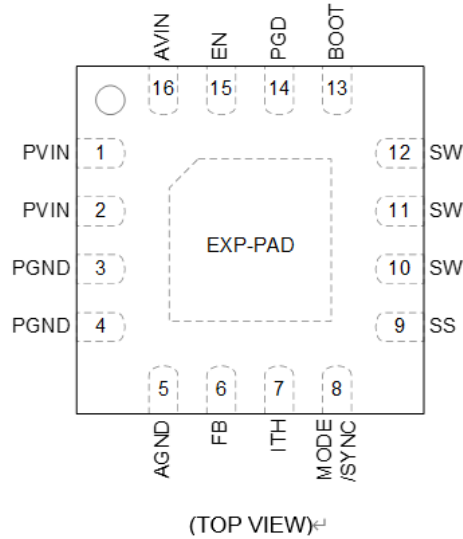

Figure 5. Pin Configuration

Pin Description

Table 2. Mode Terminal Description

| Terminal | Setting | Operation Mode | Function |
|-------------|---------------------|----------------|--|
| MODE / SYNC | HIGH | SLLM™ control | Automatically switched between SLLM™ control and PWM mode. |
| | LOW or OPEN | Forced PWM | Forced PWM mode |
| | Pulse signal (Note) | SYNC | External synchronization mode |

(Note) When pulse signal is applied at a frequency of 1.8MHz or higher, the external synchronization operation is started after the falls of the synchronous pulse are detected 7 times. Input the signal with the synchronization frequency range between 1.8MHz and 2.4MHz and the duty range between 25% and 75%

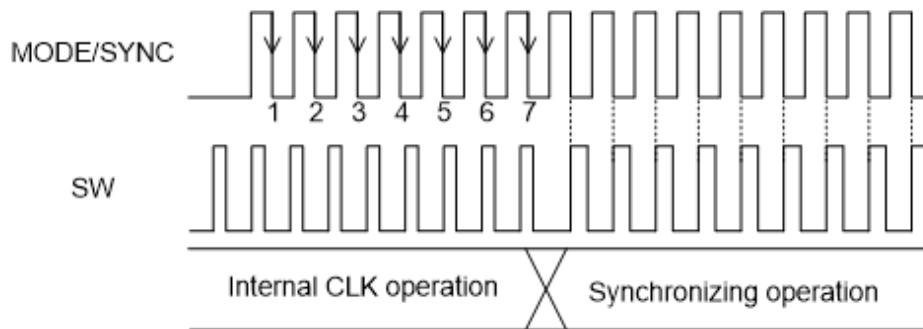

Figure 6. External Synchronization Function Timing Chart

Table 3. VIN and EN Terminal Description

| VIN PIN | EN PIN | VOUT |
|-----------------------|----------------|--------------------------|
| $VIN \geq 2.55V(TYP)$ | $EN \geq 2.0V$ | Start up with Soft Start |
| $VIN \geq 2.55V(TYP)$ | $EN \leq 0.8V$ | Shutdown |
| $VIN \leq 2.45V(TYP)$ | - | Shutdown |

Table 4. FB and PGD Terminal Description

| FB PIN | Power Good Output |
|---------------------------------------|-------------------|
| In the range of $0.8V(TYP) \pm 7\%$ | HIGH |
| Out the range of $0.8V(TYP) \pm 10\%$ | LOW |

(Note) PGD pin is an output of open drain MOSFET, and the PGD pin is pulled down with impedance of 30Ω (TYP). It is recommended to use a pull-up resistor of $10k\Omega$ to $100k\Omega$ for the power source.

Table 5. EN and FB Terminal Description

| EN Pin | FB PIN | Protection | Protection item |
|----------------|--|------------|-----------------|
| $EN \geq 2.0V$ | $0.88V(TYP) > FB \geq 0.6V(TYP)$ | Enabled | No detection |
| | $FB \leq 0.56V$ and remains $1ms(TYP)$ | | SCP |
| | $FB \geq 0.88V(TYP)$ | | OVP |
| $EN \leq 0.8V$ | - | Disabled | - |

(Note) When the FB pin voltage has fallen to $0.56V$ (TYP) or less and remained there for $1ms$ (TYP), SCP stops the operation for $14ms$ (TYP) and subsequently initiates a restart.

When the FB pin voltage becomes over or equal to $0.88V$ (TYP), which is Output Over Voltage Protection Detection Voltage, the MOSFETs on the output stage are turned OFF to prevent the increase in the output voltage.

Parts list

Table 6. Parts list (VOUT=1.0V, VIN=3.3V)

| No | Package | Parameters | Part Name (Series) | Type | Manufacturer |
|-------|---------|---------------------------|--------------------|-------------------|--------------|
| L1 | | 1.0 μ H | CLF5030NIT-1R0N-D | Inductor | TDK |
| COUT1 | 3216 | 22 μ F, X7R, 6.3V | GCM31CR70J226K | Ceramic Capacitor | Murata |
| COUT2 | 3216 | 22 μ F, X7R, 6.3V | GCM31CR70J226K | Ceramic Capacitor | Murata |
| CIN1 | 2012 | 10 μ F, X7R, 10V | GCM21BR71A106K | Ceramic Capacitor | Murata |
| CIN2 | 1005 | 0.1 μ F, X7R, 16V | GCM155R71C104K | Ceramic Capacitor | Murata |
| R100 | - | SHORT | - | - | - |
| R1 | 1005 | 7.5k Ω , 1%, 1/16W | MCR01MZPF7501 | Chip Resistor | ROHM |
| R2 | 1005 | 30k Ω , 1%, 1/16W | MCR01MZPF3002 | Chip Resistor | ROHM |
| R3 | 1005 | 8.2k Ω , 1%, 1/16W | MCR01MZPF8201 | Chip Resistor | ROHM |
| R4 | 1005 | 100k Ω , 1%, 1/16W | MCR01MZPF1003 | Chip Resistor | ROHM |
| C1 | 1005 | 0.1 μ F, X7R, 16V | GCM155R71C104K | Ceramic Capacitor | Murata |
| C2 | 1005 | 4700pF, X7R, 50V | GCM155R71H472K | Ceramic Capacitor | Murata |
| C3 | - | - | - | - | - |
| C4 | - | - | - | - | - |
| F1 | - | - | - | - | - |
| CF1 | - | - | - | - | - |
| CF2 | - | - | - | - | - |
| CF3 | - | - | - | - | - |

Table 7. Parts list (VOUT=1.2V, VIN=5.0V)

| No | Package | Parameters | Part Name (Series) | Type | Manufacturer |
|-------|---------|---------------------------|--------------------|-------------------|--------------|
| L1 | | 1.0 μ H | CLF5030NIT-1R0N-D | Inductor | TDK |
| COUT1 | 3216 | 22 μ F, X7R, 6.3V | GCM31CR70J226K | Ceramic Capacitor | Murata |
| COUT2 | 3216 | 22 μ F, X7R, 6.3V | GCM31CR70J226K | Ceramic Capacitor | Murata |
| CIN1 | 2012 | 10 μ F, X7R, 10V | GCM21BR71A106K | Ceramic Capacitor | Murata |
| CIN2 | 1005 | 0.1 μ F, X7R, 16V | GCM155R71C104K | Ceramic Capacitor | Murata |
| R100 | - | SHORT | - | - | - |
| R1 | 1005 | 10k Ω , 1%, 1/16W | MCR01MZPF1002 | Chip Resistor | ROHM |
| R2 | 1005 | 20k Ω , 1%, 1/16W | MCR01MZPF2002 | Chip Resistor | ROHM |
| R3 | 1005 | 8.2k Ω , 1%, 1/16W | MCR01MZPF8201 | Chip Resistor | ROHM |
| R4 | 1005 | 100k Ω , 1%, 1/16W | MCR01MZPF1003 | Chip Resistor | ROHM |
| C1 | 1005 | 0.1 μ F, X7R, 16V | GCM155R71C104K | Ceramic Capacitor | Murata |
| C2 | 1005 | 4700pF, X7R, 50V | GCM155R71H472K | Ceramic Capacitor | Murata |
| C3 | - | - | - | - | - |
| C4 | - | - | - | - | - |
| F1 | - | - | - | - | - |
| CF1 | - | - | - | - | - |
| CF2 | - | - | - | - | - |
| CF3 | - | - | - | - | - |

Table 8. Parts list (VOUT=1.5V, VIN=5.0V)

| No | Package | Parameters | Part Name (Series) | Type | Manufacturer |
|-------|---------|------------------|--------------------|-------------------|--------------|
| L1 | | 1.0μH | CLF5030NIT-1R0N-D | Inductor | TDK |
| COUT1 | 3216 | 22μF, X7R, 6.3V | GCM31CR70J226K | Ceramic Capacitor | Murata |
| COUT2 | 3216 | 22μF, X7R, 6.3V | GCM31CR70J226K | Ceramic Capacitor | Murata |
| CIN1 | 2012 | 10μF, X7R, 10V | GCM21BR71A106K | Ceramic Capacitor | Murata |
| CIN2 | 1005 | 0.1μF, X7R, 16V | GCM155R71C104K | Ceramic Capacitor | Murata |
| R100 | - | SHORT | - | - | - |
| R1 | 1005 | 16kΩ, 1%, 1/16W | MCR01MZPF1602 | Chip Resistor | ROHM |
| R2 | 1005 | 18kΩ, 1%, 1/16W | MCR01MZPF1802 | Chip Resistor | ROHM |
| R3 | 1005 | 12kΩ, 1%, 1/16W | MCR01MZPF1202 | Chip Resistor | ROHM |
| R4 | 1005 | 100kΩ, 1%, 1/16W | MCR01MZPF1003 | Chip Resistor | ROHM |
| C1 | 1005 | 0.1μF, X7R, 16V | GCM155R71C104K | Ceramic Capacitor | Murata |
| C2 | 1005 | 3300pF, X7R, 50V | GCM155R71H332K | Ceramic Capacitor | Murata |
| C3 | - | - | - | - | - |
| C4 | - | - | - | - | - |
| F1 | - | - | - | - | - |
| CF1 | - | - | - | - | - |
| CF2 | - | - | - | - | - |
| CF3 | - | - | - | - | - |

Table 9. Parts list (VOUT=1.8V, VIN=5.0V)

| No | Package | Parameters | Part Name (Series) | Type | Manufacturer |
|-------|---------|------------------|--------------------|-------------------|--------------|
| L1 | | 1.0μH | CLF5030NIT-1R0N-D | Inductor | TDK |
| COUT1 | 3216 | 22μF, X7R, 6.3V | GCM31CR70J226K | Ceramic Capacitor | Murata |
| COUT2 | 3216 | 22μF, X7R, 6.3V | GCM31CR70J226K | Ceramic Capacitor | Murata |
| CIN1 | 2012 | 10μF, X7R, 10V | GCM21BR71A106K | Ceramic Capacitor | Murata |
| CIN2 | 1005 | 0.1μF, X7R, 16V | GCM155R71C104K | Ceramic Capacitor | Murata |
| R100 | - | SHORT | - | - | - |
| R1 | 1005 | 30kΩ, 1%, 1/16W | MCR01MZPF3002 | Chip Resistor | ROHM |
| R2 | 1005 | 24kΩ, 1%, 1/16W | MCR01MZPF2402 | Chip Resistor | ROHM |
| R3 | 1005 | 13kΩ, 1%, 1/16W | MCR01MZPF1302 | Chip Resistor | ROHM |
| R4 | 1005 | 100kΩ, 1%, 1/16W | MCR01MZPF1003 | Chip Resistor | ROHM |
| C1 | 1005 | 0.1μF, X7R, 16V | GCM155R71C104K | Ceramic Capacitor | Murata |
| C2 | 1005 | 3300pF, X7R, 50V | GCM155R71H332K | Ceramic Capacitor | Murata |
| C3 | - | - | - | - | - |
| C4 | - | - | - | - | - |
| F1 | - | - | - | - | - |
| CF1 | - | - | - | - | - |
| CF2 | - | - | - | - | - |
| CF3 | - | - | - | - | - |

Table 10. Parts list (VOUT=3.3V, VIN=5.0V)

| No | Package | Parameters | Part Name (Series) | Type | Manufacturer |
|-------|---------|------------------|--------------------|-------------------|--------------|
| L1 | | 1.0μH | CLF5030NIT-1R0N-D | Inductor | TDK |
| COUT1 | 3216 | 22μF, X7R, 6.3V | GCM31CR70J226K | Ceramic Capacitor | Murata |
| COUT2 | 3216 | 22μF, X7R, 6.3V | GCM31CR70J226K | Ceramic Capacitor | Murata |
| CIN1 | 2012 | 10μF, X7R, 10V | GCM21BR71A106K | Ceramic Capacitor | Murata |
| CIN2 | 1005 | 0.1μF, X7R, 16V | GCM155R71C104K | Ceramic Capacitor | Murata |
| R100 | - | SHORT | - | - | - |
| R1 | 1005 | 75kΩ, 1%, 1/16W | MCR01MZPF7502 | Chip Resistor | ROHM |
| R2 | 1005 | 24kΩ, 1%, 1/16W | MCR01MZPF2402 | Chip Resistor | ROHM |
| R3 | 1005 | 20kΩ, 1%, 1/16W | MCR01MZPF2002 | Chip Resistor | ROHM |
| R4 | 1005 | 100kΩ, 1%, 1/16W | MCR01MZPF1003 | Chip Resistor | ROHM |
| C1 | 1005 | 0.1μF, X7R, 16V | GCM155R71C104K | Ceramic Capacitor | Murata |
| C2 | 1005 | 2200pF, X7R, 50V | GCM155R71H222K | Ceramic Capacitor | Murata |
| C3 | - | - | - | - | - |
| C4 | - | - | - | - | - |
| F1 | - | - | - | - | - |
| CF1 | - | - | - | - | - |
| CF2 | - | - | - | - | - |
| CF3 | - | - | - | - | - |

(Note1) $V_{OUT} = \frac{R1+R2}{R2} \times 0.8$ [V]

(Note) C3, C4, F1, CF1, CF2, CF3 patterns are only optional. They can be utilized for adjusting the characteristics constants.

Board Layout

Evaluation Board PCB information

| Number of Layers | Material | Board Size | Copper Thickness |
|------------------|----------|--------------------------|---|
| 4 | FR4 | 114.3mm x 76.2mm x 1.6mm | 2oz(70μm) / 1oz (35μm) / 1oz (35μm) / 2oz(70μm) |

The layout of BD9S300MUF-C is shown below.

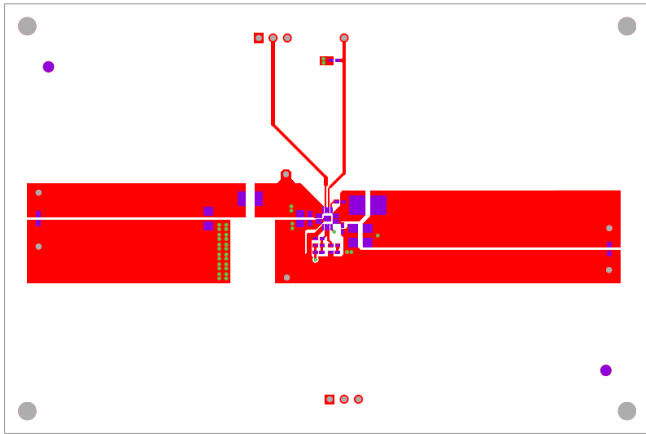

Figure 7. Top Layer Layout

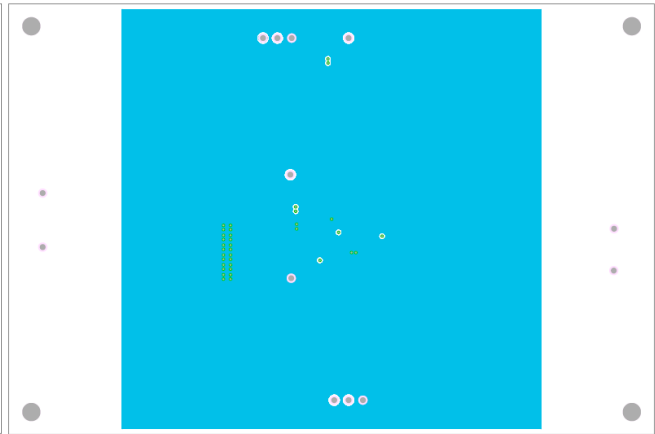

Figure 8. Middle1 Layer Layout

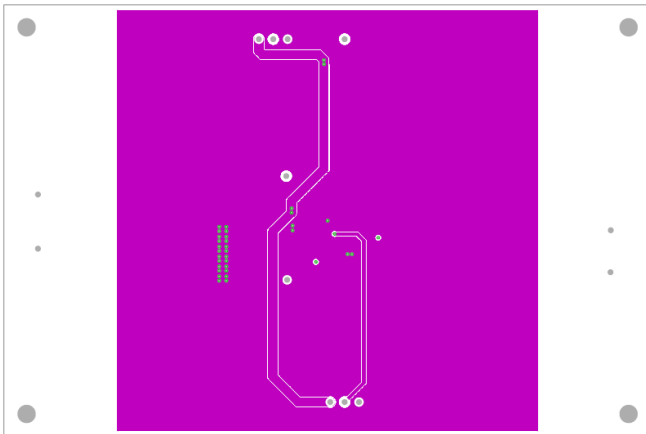

Figure 9. Middle2 Layer Layout

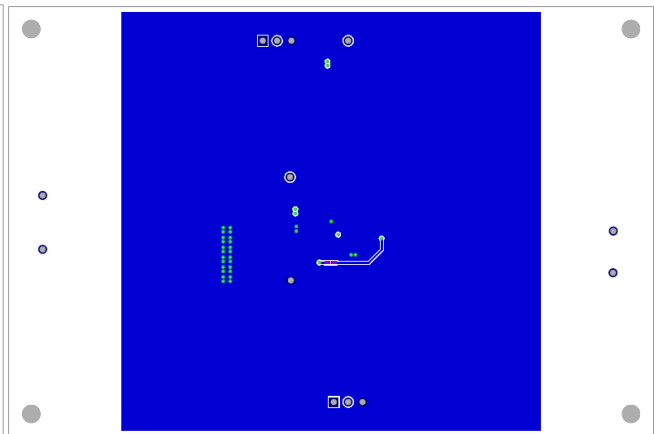

Figure 10. Bottom Layer Layout

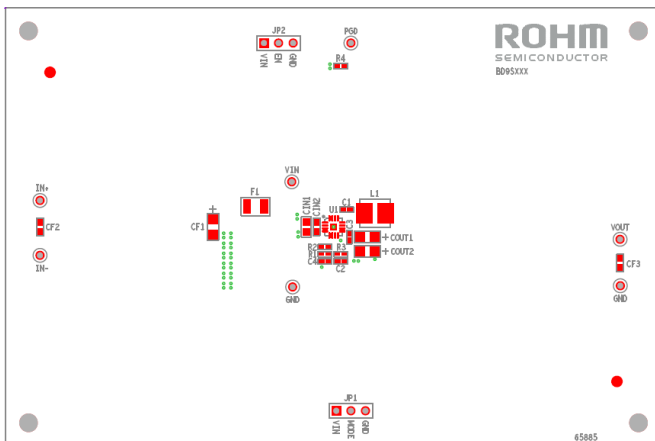

Figure 11. Top Parts Placement

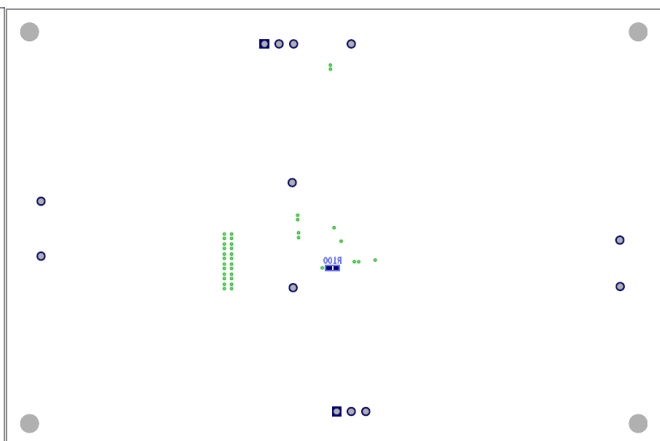

Figure 12. Bottom Parts Placement

Reference application data (BD9S300MUF-C)

($V_{IN}=V_{EN}=5.0V$, $V_{OUT}=3.3V$, $T_a=25^{\circ}C$)

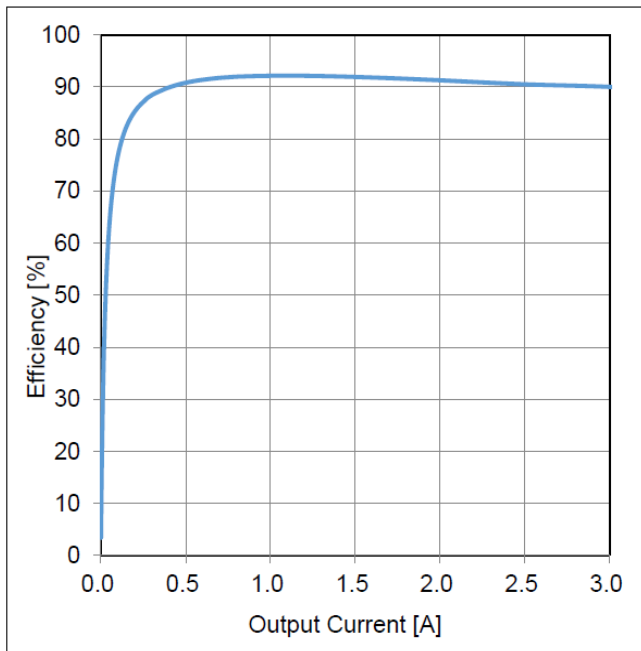

Figure 13. Efficiency vs Output Current

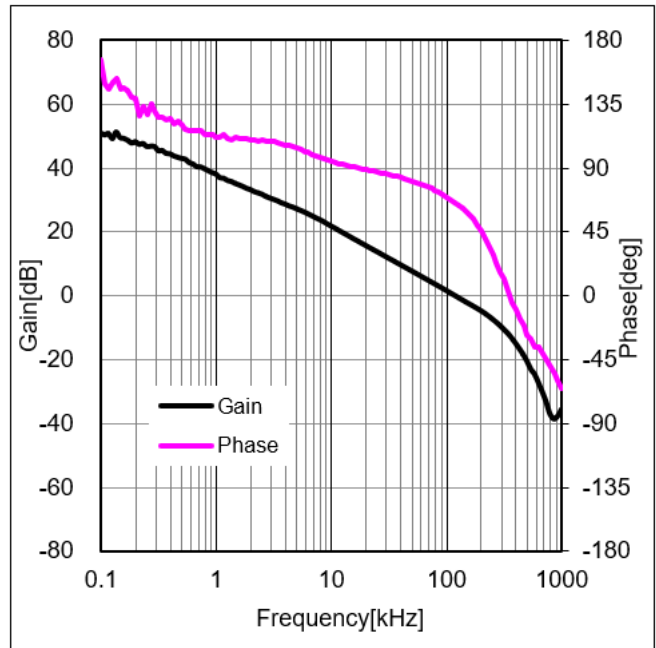

Figure 14. Frequency Characteristics ($I_{OUT}=2A$)

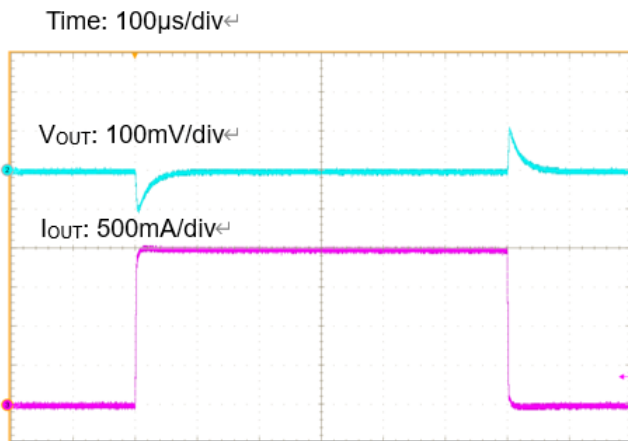

Figure 15. Load Transient Response ($I_{OUT} = 0A \leftrightarrow 1A$)

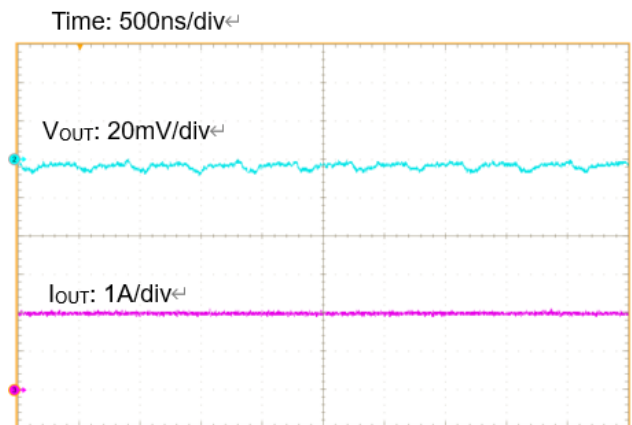

Figure 16. Output Ripple Voltage ($I_{OUT} = 2A$)

Other series application data please refer to datasheet.

Revision History

| Date | Revision Number | Description |
|--------------|------------------------|---|
| Oct. 2021 | 001 | Initial release |
| 6. Jan. 2025 | 002 | Add the VOUT setting value of Test Board to sub title |

Notice

- 1) The information contained in this document is intended to introduce ROHM Group (hereafter referred to as ROHM) products. When using ROHM products, please verify the latest specifications or datasheets before use.
- 2) ROHM products are designed and manufactured for use in general electronic equipment and applications (such as Audio Visual equipment, Office Automation equipment, telecommunication equipment, home appliances, amusement devices, etc.) or specified in the datasheets. Therefore, please contact the ROHM sales representative before using ROHM products in equipment or devices requiring extremely high reliability and whose failure or malfunction may cause danger or injury to human life or body or other serious damage (such as medical equipment, transportation, traffic, aircraft, spacecraft, nuclear power controllers, fuel control, automotive equipment including car accessories, etc. hereafter referred to as Specific Applications). Unless otherwise agreed in writing by ROHM in advance, ROHM shall not be in any way responsible or liable for any damages, expenses, or losses incurred by you or third parties arising from the use of ROHM Products for Specific Applications.
- 3) Electronic components, including semiconductors, can fail or malfunction at a certain rate. Please be sure to implement, at your own responsibilities, adequate safety measures including but not limited to fail-safe design against physical injury, and damage to any property, which a failure or malfunction of products may cause.
- 4) The information contained in this document, including application circuit examples and their constants, is intended to explain the standard operation and usage of ROHM products, and is not intended to guarantee, either explicitly or implicitly, the operation of the product in the actual equipment it will be used. As a result, you are solely responsible for it, and you must exercise your own independent verification and judgment in the use of such information contained in this document. ROHM shall not be in any way responsible or liable for any damages, expenses, or losses incurred by you or third parties arising from the use of such information.
- 5) When exporting ROHM products or technologies described in this document to other countries, you must abide by the procedures and provisions stipulated in all applicable export laws and regulations, such as the Foreign Exchange and Foreign Trade Act and the US Export Administration Regulations, and follow the necessary procedures in accordance with these provisions.
- 6) The technical information and data described in this document, including typical application circuits, are examples only and are not intended to guarantee to be free from infringement of third parties intellectual property or other rights. ROHM does not grant any license, express or implied, to implement, use, or exploit any intellectual property or other rights owned or controlled by ROHM or any third parties with respect to the information contained herein.
- 7) No part of this document may be reprinted or reproduced in any form by any means without the prior written consent of ROHM.
- 8) All information contained in this document is current as of the date of publication and subject to change without notice. Before purchasing or using ROHM products, please confirm the latest information with the ROHM sales representative.
- 9) ROHM does not warrant that the information contained herein is error-free. ROHM shall not be in any way responsible or liable for any damages, expenses, or losses incurred by you or third parties resulting from errors contained in this document.



Thank you for your accessing to ROHM product informations.
More detail product informations and catalogs are available, please contact us.

ROHM Customer Support System

<https://www.rohm.com/contactus>