

## Switching Regulator Series

# Buck Converter with Integrated FET BD9E304FP4-LBZ EVK

## BD9E304FP4-EVK-003 (12V→5V, 3.0A)

### Introduction

This user's guide provides the necessary steps to operate the EVK of ROHM's BD9E304FP4-LBZ 1-channel Buck DC/DC converter. This includes the external parts, operating procedures, and application data.

### Description

This EVK has been developed for ROHM's synchronous buck DC/DC converter customers evaluating BD9E304FP4-LBZ and outputs 5V from 24V or 12V input voltage. The BD9E304FP4-LBZ accepts a power supply input range of 4.5V to 36V and generates an output voltage ranging from  $(0.1 \times V_{IN} \text{ or } 0.7V)$  to  $0.8 \times V_{IN}$  using external resistors. The operating frequency is fixed at 300 kHz. The Light Load Mode control provides good efficiency characteristics in light load conditions, which is ideal for applications that needs to lessen the standby power. The current mode control DC/DC converter provides high-speed transient response performance. Additional protection functions include a built-in soft start function to prevent inrush current at startup, UVLO (Under Voltage Lock Out), TSD (Thermal Shutdown Detection), SCP (Short Current Protection), OCP (Over Current Protection), and OVP (Over Voltage Protection).

### Application

Industrial Products as Factory Automation  
 Secondary power supply and adapter equipment  
 Telecommunication Devices

### Operating Limits

Parameter	Min	Typ	Max	Units	Conditions
Input Voltage	10.0	12.0	36.0	V	
Output Voltage		5.0		V	
Output Current Range			3.0	A	
Operating Frequency		300		kHz	
Maximum Efficiency		95.0		%	$V_{in}=12V, I_{out}=0.6A$
UVLO Detect Voltage		3.9		V	$V_{in}$ sweep down
UVLO Hysteresis Width		350		mV	

## EVK



Figure 1. BD9E304FP4-EVK-003(Top View)

## EVK Schematic

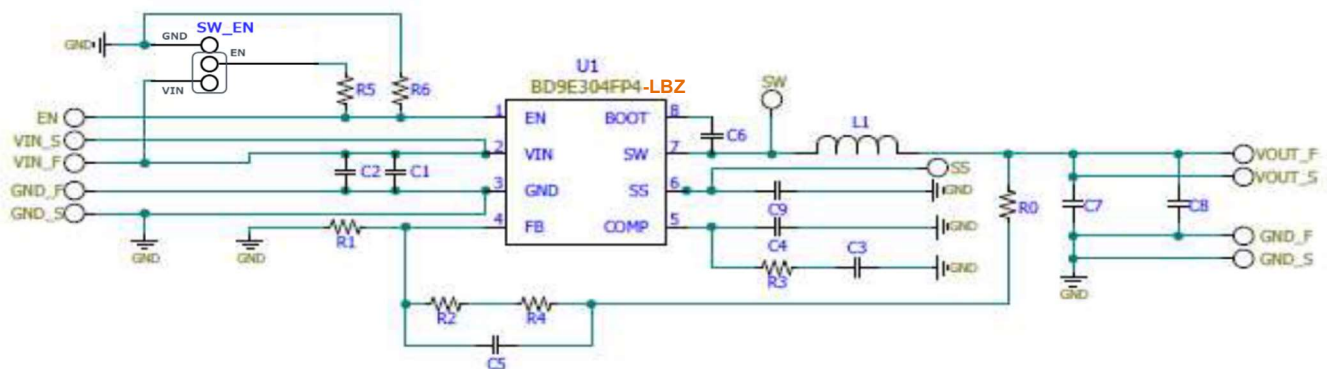

Figure 2. BD9E304FP4-EVK-003 Circuit Diagram

## Operating Procedure

1. Turn off the DC power supply and connect the GND terminal of the power supply to the GND\_F terminal (left side in EVK) of the EVK.
2. Connect the VCC pin of the DC power supply to the VIN\_F pin of the EVK.
3. Connect the load to the VOUT\_F and GND\_F (right side in EVK) terminal of EVK. When using an electronic load, connect with the load turned off.
4. Connect a voltmeter to the VOUT\_S terminal and the GND\_S terminal (right side in EVK) of EVK.
5. Connect the jumper of SW\_EN to VIN (ON) side.
6. Turn on the DC power supply. Make sure the voltmeter shows 5V.
7. Turn on the electronic load.

(Caution) This EVK does not support hot plug. Do not perform hot plug test.

## Operation State Settings

Below is a table of BD9E304FP4-LBZ condition selectable using SW\_EN.

Table 1. SW\_EN Settings

SW_EN state	BD9E304FP4-LBZ Condition
ON (short to VIN)	Enable
OFF (short to GND)	Shutdown

## Parts list

Table 2. Parts list

Parts Number	Type	Value	Size/ Size Code [Unit: mm(inch)]	Power Rating	Voltage/ Current Rating	Temp. Coefficient/ DCR	Tolera nce	Parts Name	Manufacturer	Quan tity
C1,C6	Capacitor	0.1μF	1005(0402)	-	50V	X5R	±10%	GRM155R61H104KE14	Murata	2
C2	Capacitor	10μF	3225(1210)	-	100V	X7S	±10%	GRM32EC72A106KE05	Murata	1
C7,C8	Capacitor	47μF	3216(1206)	-	16V	X5R	±10%	GRM32EB31C476KE15L	Murata	2
C5	Capacitor	120pF	0603(0201)	-	50V	C0G	±5%	GRM0335C1H121JA01	Murata	1
C3	Capacitor	680pF	0603(0201)	-	25V	C0G	±5%	GRM0335C1E681JA01	Murata	1
R3	Resistor	33k	1005(0402)	1/16W	-	-	±1%	MCR01MZPF3302	ROHM	1
R4	Resistor	15k	1005(0402)	1/16W	-	-	±1%	TRR01MZPF1502	ROHM	1
R2	Resistor	300k	1005(0402)	1/16W	-	-	±1%	TRR01MZPF3003	ROHM	1
R1	Resistor	43k	1005(0402)	1/16W	-	-	±1%	TRR01MZPF4302	ROHM	1
L1	Inductor	15μH	100100(4040)	-	Ist=5.1A	DCR=35.2mΩ ±20%	±20%	1274AS-H-150M#	Murata	1
U1	IC	-	2.80x2.92	-	-	-	-	BD9E304FP4-LBZ	ROHM	1
R5	-	Short	Soldering	-	-	-	-	Shorted by Solder	-	0
R6	-	Open		-	-	-	-	-	-	0
R0	-	Short	Soldering	-	-	-	-	Shorted by Solder	-	0
EN, VIN_S,VIN_F, GND_Fx2, GND_Sx2, SS, VOUT_S, VOUT_F	Test Pin	-	1mm Hole	-	10A	-	-	ST-2-2	Mac8	10
SW_EN	Header	-	-	-	-	-	-	68000-103HLF	Amphenol FCi	1
SW_EN	Jumper	-	-	-	-	-	-	QPC02SXGN-RC	SULLINS	1

### Board Layout

EVK PCB information

Number of Layers	Material	Board Size	Copper Thickness
4	FR-4	67.5mm x 67.5mm x 1.6mmt	1oz (35µm)

The layout of BD9E304FP4-EVK-003 is shown below.

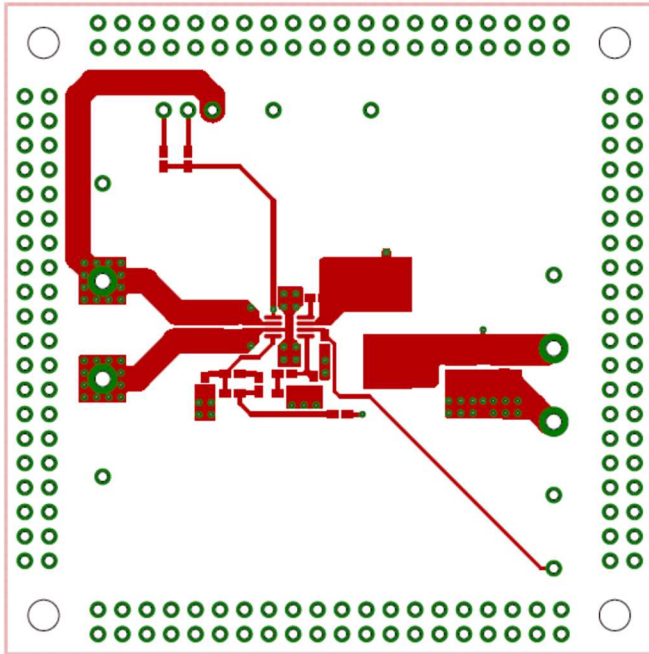

Figure 3. Top Layer Layout  
(Top View)

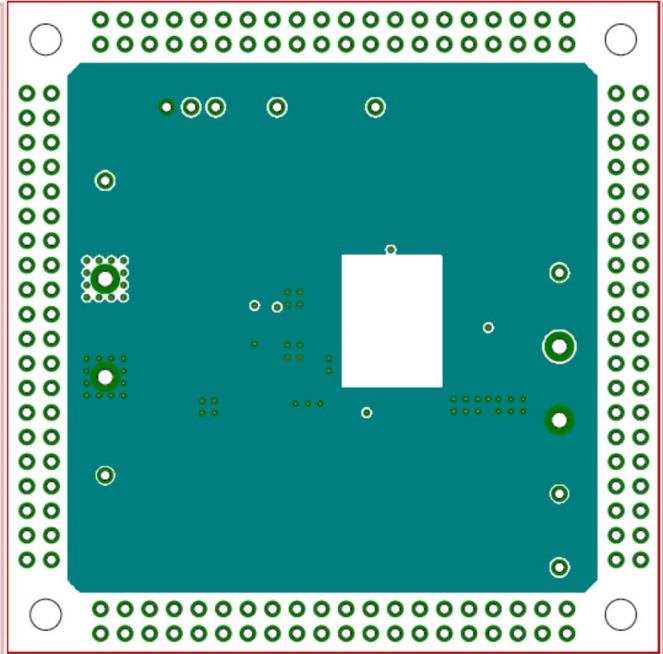

Figure 4. Middle1 Layer Layout  
(Top View)

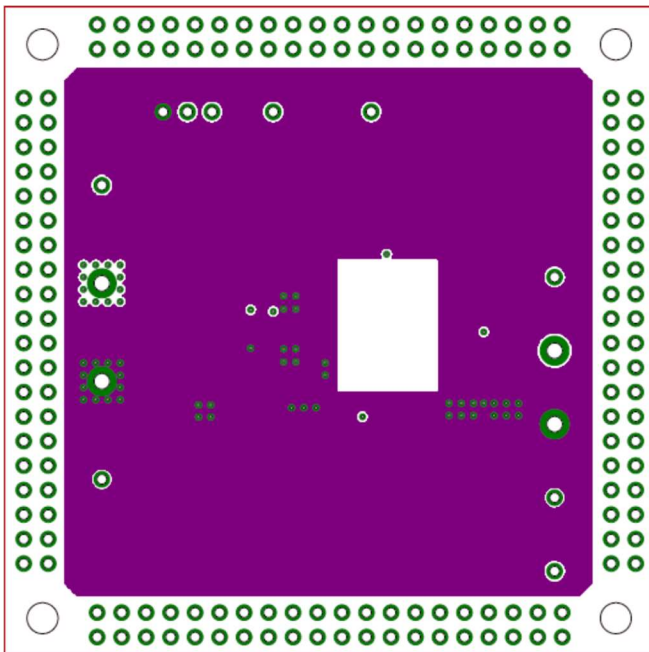

Figure 5. Middle2 Layer Layout  
(Top View)

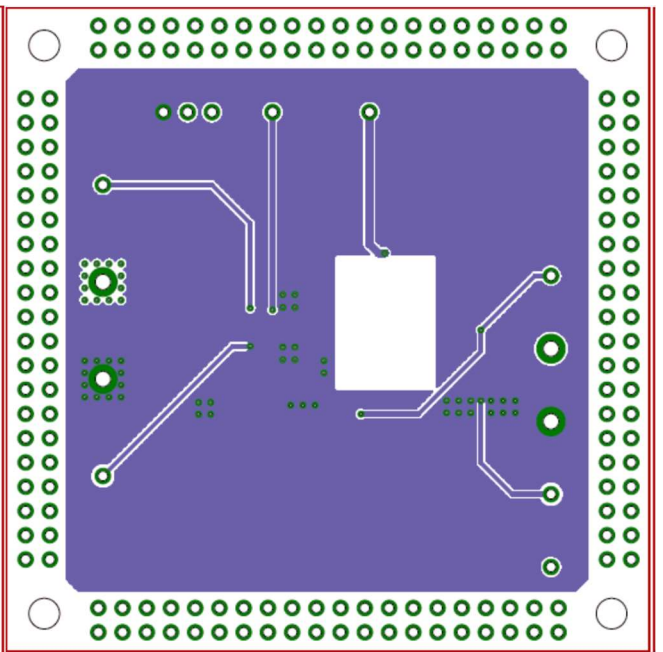

Figure 6. Bottom Layer Layout  
(Top View)

Reference application data

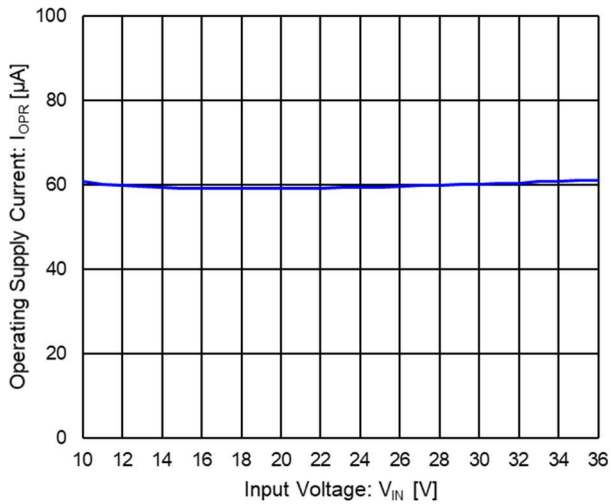

Figure 7. Operating Quiescent Current vs Input Voltage  
( $V_{IN}=12V$ ,  $V_{OUT}=5V$ ,  $I_{OUT}=0A$ )

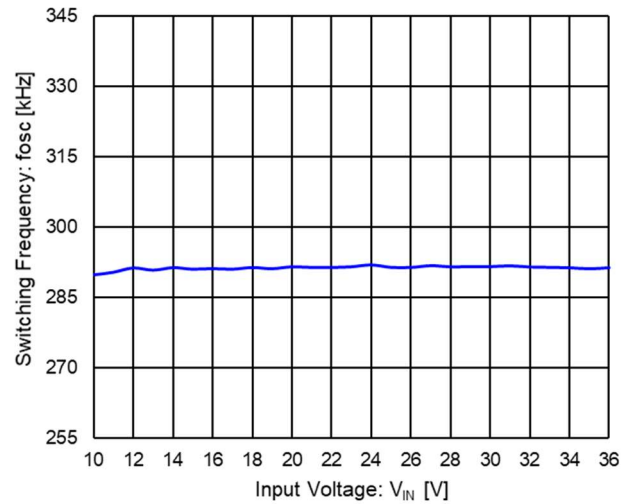

Figure 8. Switching Frequency vs Input Voltage  
( $V_{OUT}=5V$ ,  $I_{OUT}=3A$ )

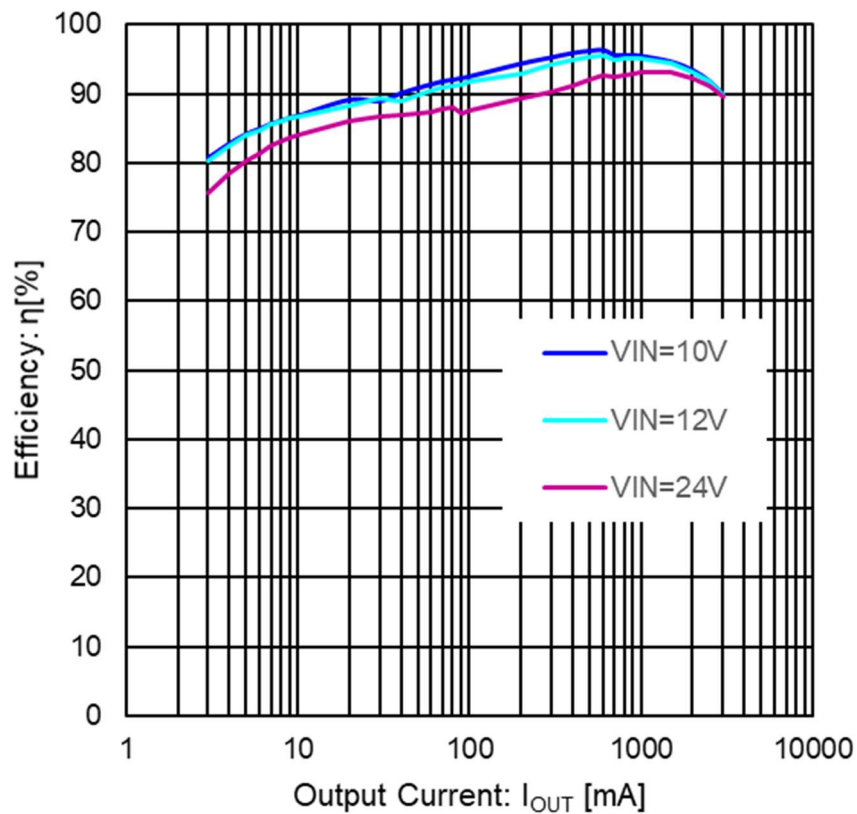

Figure 9. Efficiency vs Output Current ( $V_{OUT}=5V$ )

Reference application data - continued

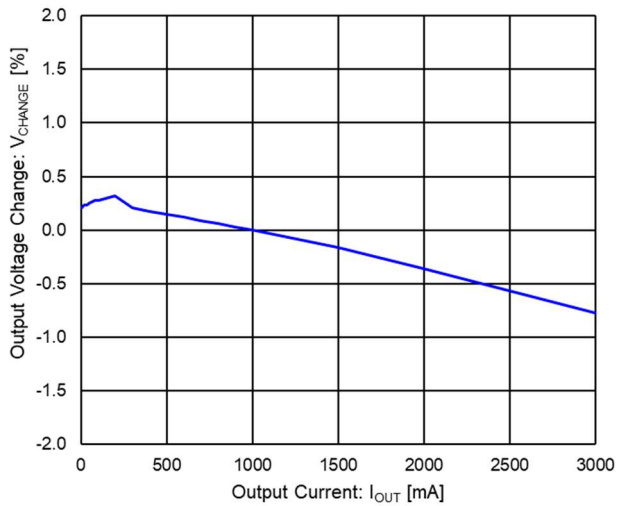

Figure 10. V<sub>OUT</sub> Load Regulation  
(V<sub>IN</sub>=12V, V<sub>OUT</sub>=5V)

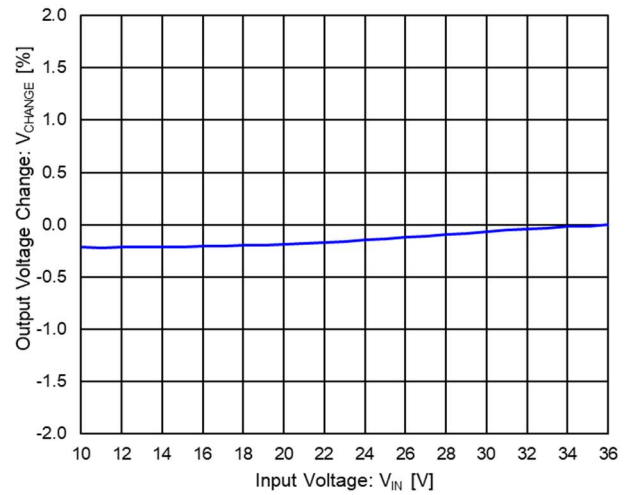

Figure 11. V<sub>OUT</sub> Line Regulation  
(V<sub>OUT</sub>=5V, I<sub>OUT</sub>=3A)

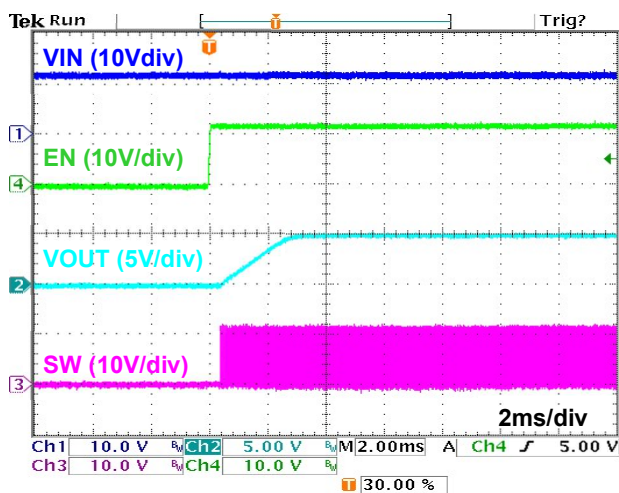

Figure 12. Rise-up Waveform  
(V<sub>EN</sub>=0V→12V, I<sub>OUT</sub>=3A)

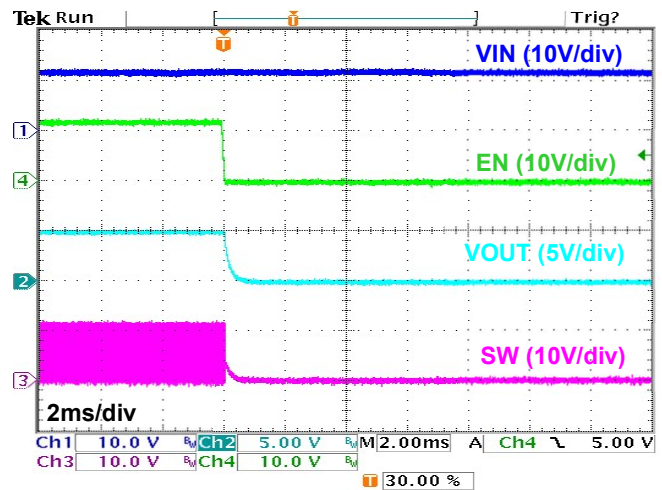

Figure 13. Shut-down Waveform  
(V<sub>EN</sub>=12V→0V, I<sub>OUT</sub>=3A)

Reference application data - continued

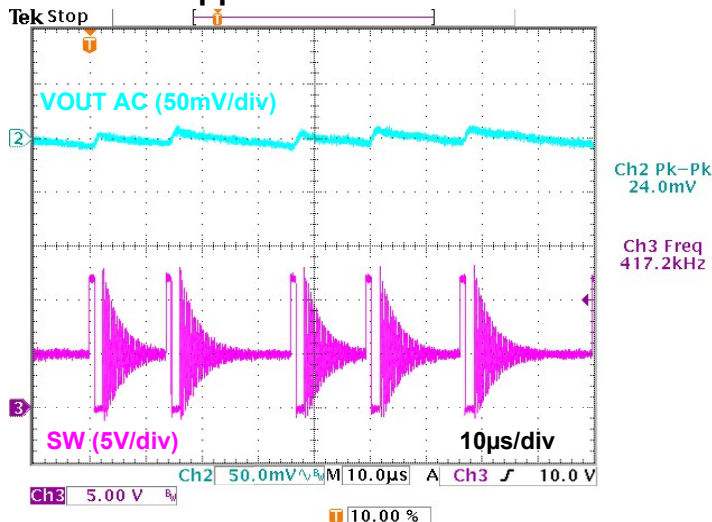

Figure 14. SW Waveform  
(VIN=12V, VOUT=5V, IOUT=30mA)

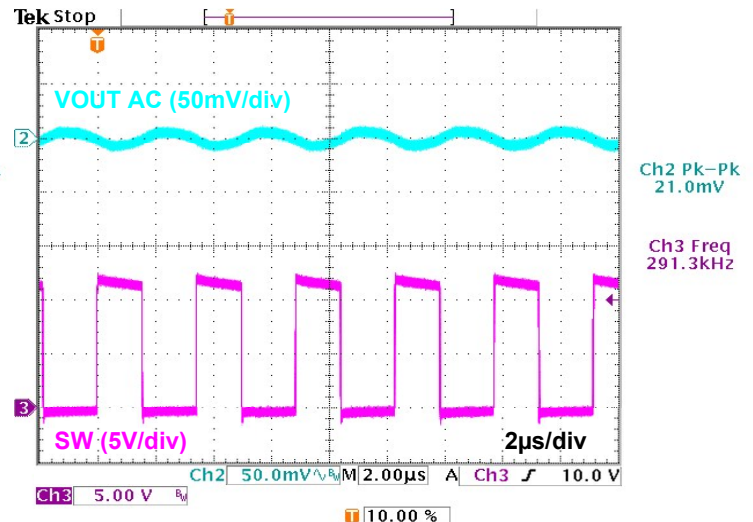

Figure 15. SW Waveform  
(VIN=12V, VOUT=5V, IOUT=3A)

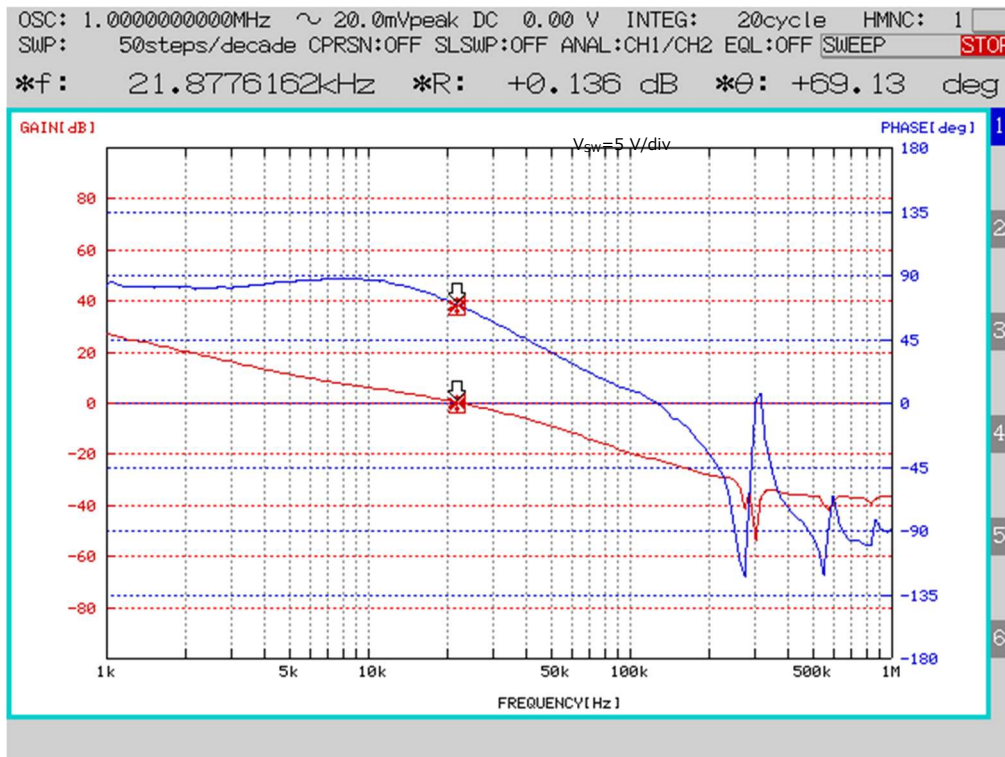

Figure 16. Frequency Response  
(VIN=12V, VOUT=5V, IOUT=3A)

## Products lists in the Parts list

The product names listed in the parts list are available during the time of creating this user's guide. In case some parts are no longer available in the future, select the equivalent products.

## Selection of Ceramic Capacitors

In selecting the ceramic capacitors, consider the DC bias characteristics and select the parts with equivalent actual capacitance of capacitors in the Parts List (Table 2). For reference, Figure 17 shows the DC bias characteristics of GRM32EC72A106KE05 (Murata) listed as C2 in the Parts list (Table 2). Actual capacitance degrades to 8.1 $\mu$ F under the condition of 12V output (DC bias voltage is 12V). When selecting an alternative component, select the product that has same capacitance under 12V of DC bias voltage. (The data shown in Figure 17 is for reference only. Please check with the capacitor manufacturer for the DC bias characteristics of ceramic capacitors.)

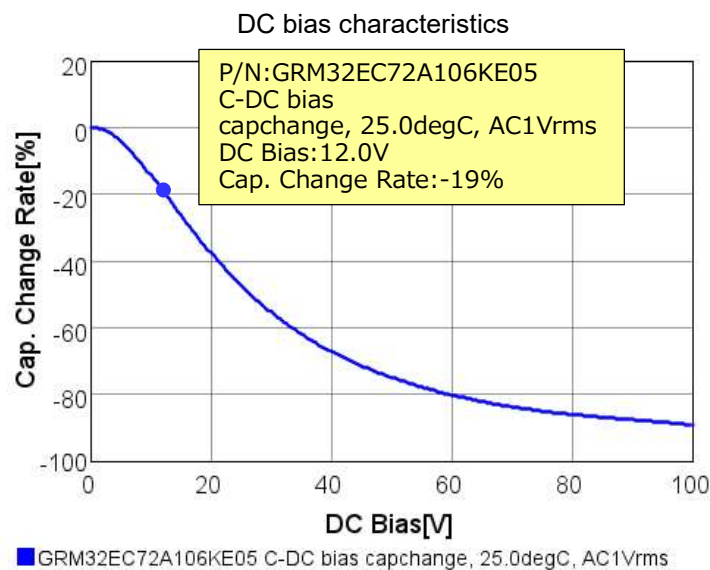

Figure 17. GRM32EC72A106KE05 (Murata) DC bias characteristics



## Revision History

Date	Revision Number	Description
21.Feb.2022	001	Initial release

## Notes

- 1) The information contained herein is subject to change without notice.
- 2) Before you use our Products, please contact our sales representative and verify the latest specifications :
- 3) Although ROHM is continuously working to improve product reliability and quality, semiconductors can break down and malfunction due to various factors.  
Therefore, in order to prevent personal injury or fire arising from failure, please take safety measures such as complying with the derating characteristics, implementing redundant and fire prevention designs, and utilizing backups and fail-safe procedures. ROHM shall have no responsibility for any damages arising out of the use of our Products beyond the rating specified by ROHM.
- 4) Examples of application circuits, circuit constants and any other information contained herein are provided only to illustrate the standard usage and operations of the Products. The peripheral conditions must be taken into account when designing circuits for mass production.
- 5) The technical information specified herein is intended only to show the typical functions of and examples of application circuits for the Products. ROHM does not grant you, explicitly or implicitly, any license to use or exercise intellectual property or other rights held by ROHM or any other parties. ROHM shall have no responsibility whatsoever for any dispute arising out of the use of such technical information.
- 6) The Products specified in this document are not designed to be radiation tolerant.
- 7) For use of our Products in applications requiring a high degree of reliability (as exemplified below), please contact and consult with a ROHM representative : transportation equipment (i.e. cars, ships, trains), primary communication equipment, traffic lights, fire/crime prevention, safety equipment, medical systems, servers, solar cells, and power transmission systems.
- 8) Do not use our Products in applications requiring extremely high reliability, such as aerospace equipment, nuclear power control systems, and submarine repeaters.
- 9) ROHM shall have no responsibility for any damages or injury arising from non-compliance with the recommended usage conditions and specifications contained herein.
- 10) ROHM has used reasonable care to ensure the accuracy of the information contained in this document. However, ROHM does not warrants that such information is error-free, and ROHM shall have no responsibility for any damages arising from any inaccuracy or misprint of such information.
- 11) Please use the Products in accordance with any applicable environmental laws and regulations, such as the RoHS Directive. For more details, including RoHS compatibility, please contact a ROHM sales office. ROHM shall have no responsibility for any damages or losses resulting non-compliance with any applicable laws or regulations.
- 12) When providing our Products and technologies contained in this document to other countries, you must abide by the procedures and provisions stipulated in all applicable export laws and regulations, including without limitation the US Export Administration Regulations and the Foreign Exchange and Foreign Trade Act.
- 13) This document, in part or in whole, may not be reprinted or reproduced without prior consent of ROHM.



Thank you for your accessing to ROHM product informations.  
More detail product informations and catalogs are available, please contact us.

## ROHM Customer Support System

<http://www.rohm.com/contact/>