

PWM type AC/DC converter IC BM1Pxxx Series PWM Flyback Converter Technical Design

This application note describes the design of PWM flyback converters using ROHM's AC/DC converter IC BM1Pxxx series devices. It explains the selection of external components and provides PCB layout guidelines. Please note that all performance characteristics have to be verified. They are not guaranteed by the PCB layout shown here.

• Description

The BM1Pxxx series of ICs are AC/DC converters for PWM switching, incorporating a built-in starter circuit having withstanding voltage of 650V. Use of external switching MOSFET and current detection resistors, provides a higher degree of design freedom. Power efficiency is improved because of the built-in starter circuit, and by the reduction of switching frequency under light load conditions. A frequency-hopping function is also built-in, which contributes to low EMI. BM1Pxxx supports both isolated and non-isolated circuits, enabling simpler design of various types of low-power converters.

• Key features

- PWM frequency 65kHz/ 100kHz (with frequency-hopping function)/ Current mode
- Burst-operation and frequency reduction when the load is light
- Built-in 650V starter circuit
- VCC pin Under-voltage protection
- VCC pin Over-voltage protection
- CS pin Open protection
- CS pin Leading-Edge-Blanking function
- Per-cycle over-current limiter function
- Over-current limiter with AC voltage compensation
- Soft-start function
- Secondary over current protection circuit

• Basic specifications

Operating power supply voltage range(VCC)	: 8.9V to 26.0V
VH voltage range(VH pin)	: up to 600V
Operating current	: Normal mode 0.60 mA (Typ)
	: Burst mode 0.35 mA (Typ)
Operating frequency	: BM1P06xFJ 65 KHz (Typ.)
	: BM1P10xFJ 100 KHz (Typ.)
Operating temperature range	: -40°C to +85°C

• BM1Pxxx Series line-up

Product	Package	PWM frequency	VCC OVP
BM1P061FJ	SOP-J8	65 kHz	Auto restart
BM1P062FJ			Latch stop
BM1P101FJ		100 kHz	Auto restart
BM1P102FJ			Latch stop

• Applications

AC adapters, TVs, household appliances (vacuum cleaners, humidifiers, air filters, air conditioners, refrigerators, induction heating cookers, rice cookers, etc.)

1. Design Example of Isolated Type Flyback Converter DCM (Discontinuous Conduction Mode)

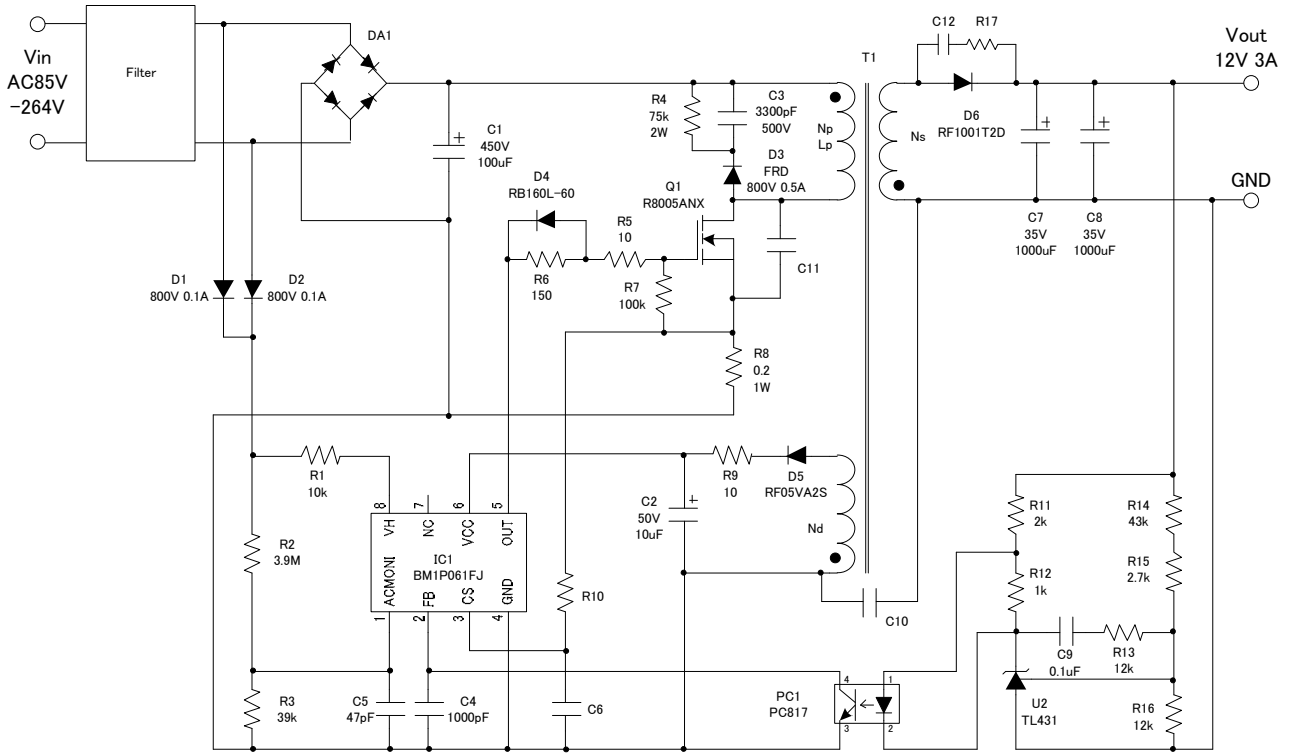
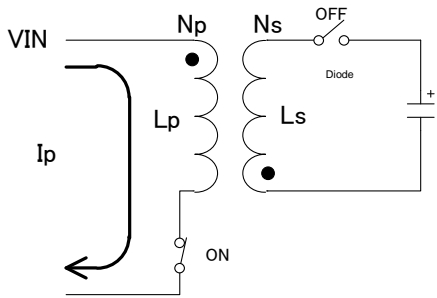

Figure 1-1. Isolated Type Flyback Converter Circuit Example

Basic operation of flyback converter

(1) When switching is turned ON



When MOSFET is ON, current I_p flows through the transformer's primary-side winding L_p , and energy is accumulated.

At that time, the diode is off.

$$I_p = \frac{V_{IN}}{L_p} \times t_{on}$$

(2) When switching is turned OFF

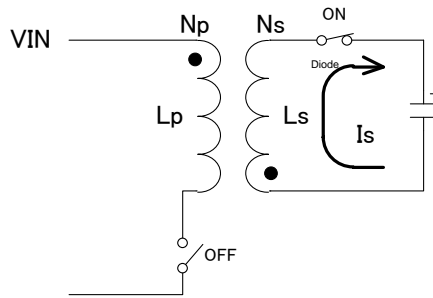

When MOSFET is OFF, the accumulated energy is output from the secondary-side winding L_s , current I_s flows via the diode.

$$I_s = \frac{N_p}{N_s} \times I_p - \frac{V_O}{L_s} \times t_{off}$$

$$V_O = \frac{N_s}{N_p} \times \frac{t_{on}}{t_{off}} \times V_{IN}$$

1-1. Transformer T1 design

1-1-1. Determination of flyback voltage VOR

Flyback voltage VOR is determined along with turns-ratio $N_p:N_s$ and duty-ratio.

$$VOR = VO \times \frac{N_p}{N_s} = \frac{t_{on}}{t_{off}} \times VIN$$

$$\Rightarrow \frac{N_p}{N_s} = \frac{VOR}{VO}$$

$$\Rightarrow \text{Duty} = \frac{VOR}{VIN + VOR}$$

When $VIN = 95V$ (AC $85V \times 1.4 \times 0.8$), $VOR = 65V$, $V_f = 1V$:

$$\frac{N_p}{N_s} = \frac{VOR}{VO} = \frac{VOR}{V_{out} + V_f} = \frac{65V}{12V + 1V} = 5$$

$$\text{Duty(max)} = \frac{VOR}{VIN(\text{min}) + VOR} = \frac{65V}{95V + 65V} = 0.406$$

(*) When duty is 0.5 or above, VOR is adjusted to set it below 0.5.

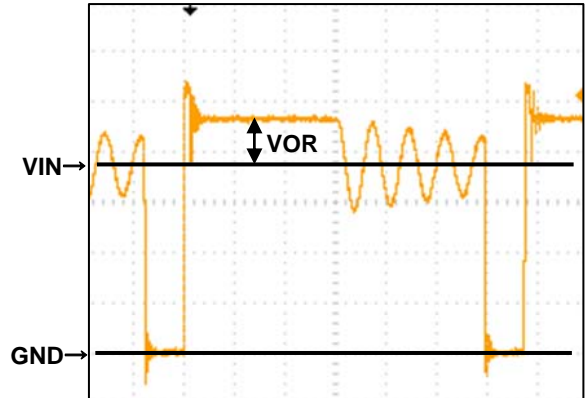

Figure 1-2. MOSFET Vds

1-1-2. Calculation of secondary-side winding inductance L_s and secondary-side maximum current I_{spk}

secondary-side maximum current I_{spk}

For better power efficiency, if $I_{omax} = I_o \times 1.2 = 3.6A$:

$$L_s < \frac{(V_{out} + V_f) \times (1 - \text{Duty})^2}{2 \times I_{omax} \times f_{swmax}}$$

$$= \frac{(12V + 1V) \times (1 - 0.406)^2}{2 \times 3.6A \times 70kHz} = 9.1\mu H$$

$$I_{spk} = \frac{2 \times I_{omax}}{1 - \text{Duty(max)}} = \frac{2 \times 3.6A}{1 - 0.406} = 12.1A$$

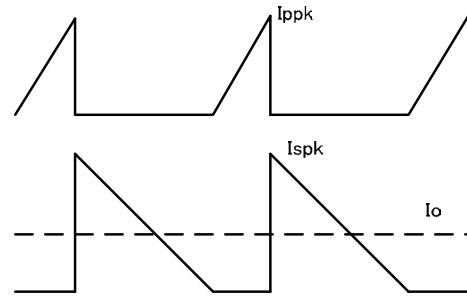

Figure 1-3. Primary-side and Secondary-side Current Waveforms

1-1-3. Calculation of primary-side winding inductance L_p and primary-side maximum current I_{ppk}

$$L_p = L_s \times \left(\frac{N_p}{N_s}\right)^2 = 9.1\mu H \times 5^2 = 228\mu H$$

$$I_{ppk} = I_{spk} \times \frac{N_s}{N_p} = 12.1A \times \frac{1}{5} = 2.42A$$

1-1-4. Determination of transformer size

Based on $P_o = 36W$, the transformer's core size is EER28.

Table 1-1. Output Voltage and Transformer Core

Output voltage P_o (W)	Core size	Core sectional area A_e (mm ²)
~30	EI25/EE25	41
~60	EI28/EE28/EER28	84

(*) The above are guideline values. For details, check with the transformer manufacturer, etc.

1-1-5. Calculation of primary-side turn count N_p

$$N_p > \frac{V_{IN} \times t_{on}}{A_e \times B_{sat}} = \frac{L_p \times I_{ppk}}{A_e \times B_{sat}}$$

Generally, the maximum magnetic flux density $B(T)$ for an ordinary ferrite core is 0.4T @100°C, so $B_{sat} = 0.3T$.

$$N_p > \frac{L_p \times I_{ppk}}{A_e \times B_{sat}} = \frac{228 \mu H \times 2.42A}{84mm^2 \times 0.3T} = 21.9 \text{ turns} \rightarrow N_p \text{ is 22 turns or above}$$

Since magnetic saturation does not result from this, N_p is set based on the AL-value—NI characteristics.

When AL-value = 150 nH/turns² is set,

$$N_p = \sqrt{\frac{L_p}{AL\text{-Value}}} = \sqrt{\frac{228\mu H}{150nH/turns^2}} = 38.9 \text{ turns} \rightarrow 40 \text{ turns}$$

$$NI = N_p \times I_{ppk} = 40turns \times 2.42A = 96.8A \cdot turns$$

The AL-value—NI characteristics of EER28 are used to confirm that this is within the tolerance range.

When it is beyond the tolerance range, N_p is adjusted.

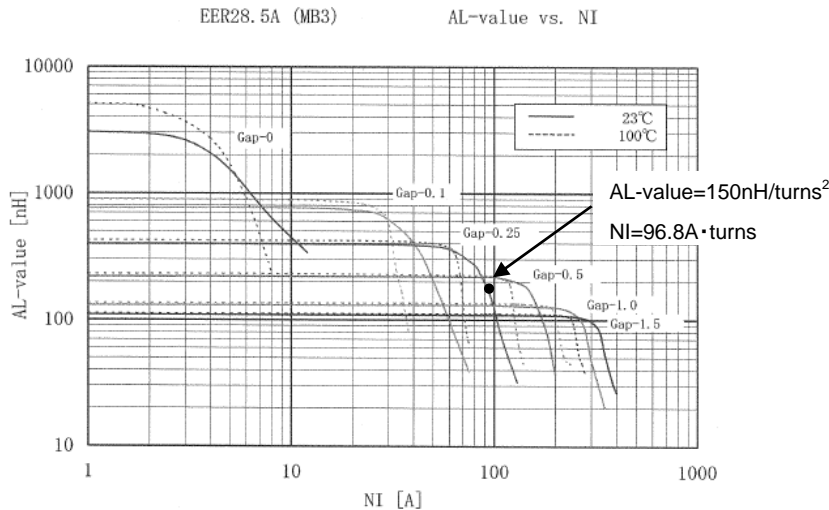

Figure 1-4. EER28 AL-value vs. NI Limit Characteristics (JFE MB3 EER28.5A)

1-1-6. Calculation of secondary-side turn count N_s

$$\frac{N_p}{N_s} = 5 \rightarrow N_s = \frac{40}{5} = 8 \text{ turns} \rightarrow 8 \text{ turns}$$

1-1-7. Calculation of VCC turn count N_d

When $V_{CC} = 15V$, $V_{f_vcc} = 1V$,

$$N_d = N_s \times \frac{V_{CC} + V_{f_vcc}}{V_{out} + V_f} = 8turns \times \frac{15V + 1V}{12V + 1V} = 9.85 \text{ turns} \rightarrow 10 \text{ turns}$$

As a result, the transformer specifications are as follows.

Table 1-2. Transformer Specifications

Core	JFE MB3 EER28.5A or compatible
L_p	228 μH
N_p	40 turns
N_s	8 turns
N_d	10 turns

1-2. Selection of main components

1-2-1. MOSFET: Q1

Factors to consider when selecting a MOSFET includes the maximum drain-source voltage, peak current, loss due to Ron, and the package's maximum allowable loss.

In particular, in the case of world-wide input (AC 85V to AC264 V, etc.), the MOSFET's ON-period is longer when the input voltage is low, and heat generation due to Ron-loss becomes greater. Confirm while the MOSFET is assembled in the product, and, when necessary, use a heat-sink or similar to dissipate the heat.

In this design example, ROHM's MOSFET R8005ANX (800V, 5A, 1.6Ω) is selected based on worldwide input and Ippk = 2.42A.

1-2-2. Input capacitor: C1

Use Table 1-3 to select the capacitance of the input capacitor.

Since Pout = 12V × 3A = 36W, C1 = 2 × 36 = 72 → 100μF.

Table 1-3. Input Capacitor Selection Table

Input voltage (Vac)	Cin (μF)
85-264V	2 × Pout (W)
180-264V	1 × Pout (W)

(*) The above values are guidelines for full-wave rectification. When selecting, also consider other specifications such as the retention-time.

The withstanding voltage of the capacitor becomes, Vac (max) × 1.41. Say for AC 264V, it is 264V × 1.41 = 372V, so this should be 400V or more.

1-2-3. Current-sensing resistor: R8

The current-sensing resistor limits the current that flows on the primary side to provide protection against output overload, and is used for slope compensation of current mode control. Consequently, in some cases limits may be imposed according to the transformer's primary-side inductance and input voltage.

In the BM1Pxxx Series, an AC voltage correction function is built-in the chip for overload protection. This corrects offsetting of the overload protection point caused by different input voltages (such as AC 100V and AC 200V).

$$R8 = \frac{V_{cs_limit}}{I_{ppk}} = \frac{V_{cs} + t_{on} \times 20mV/\mu s}{I_{ppk}} = \frac{V_{cs} + \frac{Duty}{f_{sw}} \times 20mV/\mu s}{I_{ppk}} = \frac{0.4V + \frac{0.406}{65kHz} \times 20mV/\mu s}{2.42A} = 0.217 \Omega \rightarrow 0.2 \Omega$$

Confirm the overload protection point while the resistor is assembled in the product.

Sensing resistance loss P_R8:

$$P_{R8(peak)} = I_{ppk}^2 \times R8 = 2.42^2 \times 0.2 = 1.17W$$

$$P_{R8(rms)} = I_{prms}^2 \times R8 = \left(I_{ppk} \times \sqrt{\frac{Duty}{3}} \right)^2 \times R8 = \left(2.42 \times \sqrt{\frac{0.406}{3}} \right)^2 \times 0.2 = 0.15W$$

Set to 1W or above in consideration of pulse resistance.

With regard to pulse resistance, the structure of the resistance may vary even with the same power rating.

Check with the resistor manufacturers for details.

1-2-4. VCC-diode: D5

A high-speed diode is recommended as the VCC-diode.

Reverse voltage applied to the VCC-diode:

$$V_{dr} = V_{CC(max)} + V_{INmax} \times \frac{N_d}{N_p}$$

When VCC (max) = 29 V,

$$V_{dr} = 29V + 372V \times \frac{10}{40} = 122V$$

With a design-margin taken into account, 122.5V / 0.7 = 175V → 200V component is selected.

(Example: ROHM's RF05VA2S 200V, 0.5A)

1-2-5. VCC capacitor: C2

A VCC capacitor is needed to stabilize the IC's VCC voltage. Capacitance of 2.2μF or above is recommended (example: 50V, 10μF).
Next, determine the startup time of the IC at power-on.
Figure 1-5 illustrates VCC capacitor capacitance and startup time characteristics.

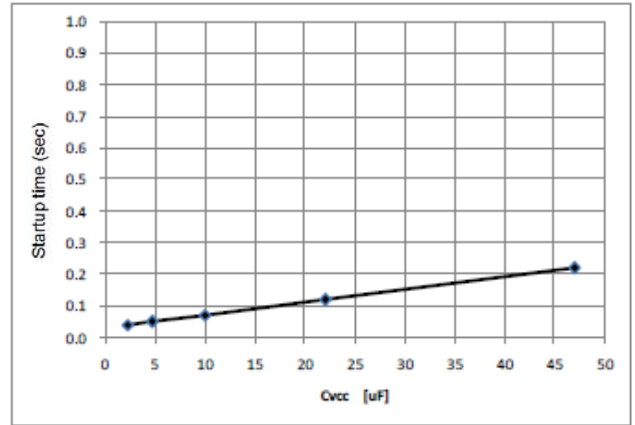

Figure 1-5. Startup Time (Reference Values)

1-2-6. VCC winding surge-voltage limiting resistor: R9

Based on the transformer's leakage inductance (Lleak), a large surge-voltage (spike noise) may occur during the instant when the MOSFET is switched from ON to OFF. This surge-voltage is induced in the VCC winding, and as the VCC voltage increases the IC's VCC overvoltage protection may be triggered.
A limiting resistor R2 (approximately 5Ω to 22Ω) is inserted to reduce the surge-voltage that is induced in the VCC winding. Confirm the rise in VCC voltage while the resistor is assembled in the product.

1-2-7. Snubber circuits: C3, D3, R4

Based on the transformer's leakage inductance (Lleak), a large surge-voltage (spike noise) may occur during the instant when the MOSFET is switched from ON to OFF. This surge-voltage is applied between the MOSFET's Drain and Source, so in the worst case damage to MOSFET might occur. RCD snubber circuits are recommended to suppress this surge-voltage.

(1) Determination of clamp voltage (Vclamp) and clamp ripple-voltage (Vripple)

Consider to take a design-margin based on the MOSFET's withstand voltage, when determining the clamp voltage.

$$V_{clamp} = 800V \times 0.8 = 640V$$

The clamp ripple-voltage (Vripple) is about 50V.

(2) Determination of R4

$$R4 < 2 \times V_{clamp} \times \frac{V_{clamp} - V_{OR}}{L_{leak} \times I_p^2 \times f_{sw(max)}}$$

When $L_{leak} = L_p \times 10\% = 228\mu H \times 10\% = 23\mu H$, R4 is derived as:

$$R4 < 2 \times 640V \times \frac{640V - 65V}{23\mu H \times 2.42^2 \times 70kHz} = 78k\Omega \rightarrow 75k\Omega$$

R4 loss P_R4 is expressed as

$$P_{R4} = \frac{(V_{clamp} - V_{IN})^2}{R4} = \frac{(640 - 372)^2}{75k\Omega} = 0.96W$$

A 2W component is determined with consideration for design margin.

(3) Determination of C3

$$C3 > \frac{V_{clamp}}{V_{ripple} \times f_{sw(min)} \times R4} = \frac{640V}{50V \times 60kHz \times 75k\Omega} = 2844pF \rightarrow 3300pF$$

The voltage applied to C3 is $640V - 264 \times 1.41 = 268V$.

400V or above is set with consideration for design margin.

(4) Determination of D3

Choose a fast recovery diode as the diode, with a withstanding voltage that is at or above the MOSFET's Vds (max) value.

The surge-voltage affects not only the transformer's leakage inductance but also the PCB substrate's pattern. Confirm the Vds voltage while assembled in the product, and adjust the snubber circuit as necessary.

1-2-8. Output rectification diode: D6

Choose a high-speed diode (Schottky barrier diode or fast recovery diode) as the output rectification diode.

Reverse voltage applied to output diode is

$$V_{dr} = V_{out(max)} + V_{INmax} \times \frac{N_s}{N_p}$$

When $V_{out} (max) = 12 V + 5\% = 12.6V$:

$$V_{dr} = 12.6V + 372V \times \frac{8}{40} = 87V$$

A $87.4V/0.7 = 125V \rightarrow 200V$ component is determined with consideration for design margin.

Also, diode loss (approximate value) becomes $P_d = V_f \times I_{out} = 1V \times 3A = 3W$.

(Example: Rohm RF1001T2D: 200V, 10A, TO-220F package)

Use of a voltage margin of 70% or less and current of 50% or less is recommended.

Check temperature rise while assembled in the product. When necessary, reconsider the component and use a heat sink or similar to dissipate the heat.

1-2-9. Output capacitors: C7, C8

Determine the output capacitors based on the output load's allowable peak-to-peak ripple voltage (ΔV_{pp}) and ripple-current. When the MOSFET is ON, the output diode is OFF. At that time, current is supplied to the load from the output capacitors. When the MOSFET is OFF, the output diode is ON. At that time, the output capacitors are charged and a load current is also supplied.

When $\Delta V_{pp} = 200mV$,

$$Z_C < \frac{\Delta V_{pp}}{I_{spk}} = \frac{0.2V}{12.1A} = 0.0165 \Omega \quad \text{at } 60kHz \text{ (fsw min)}$$

With an ordinary switching power supply electrolytic-capacitor (low-impedance component), impedance is rated at 100kHz, so it is converted to 100kHz.

$$Z_C < 0.0165 \Omega \times \frac{60}{100} = 0.01 \Omega \quad \text{at } 100kHz$$

Ripple-current I_s (rms):

$$I_s(rms) = I_{spk} \times \sqrt{\frac{1 - Duty}{3}} = 12.1A \times \sqrt{\frac{1 - 0.406}{3}} = 5.384A$$

The capacitor's withstanding voltage should be set to about twice the output voltage.

$V_{out} \times 2 = 12V \times 2 = 24V \rightarrow 25V$ or above

Select an electrolytic capacitor that is suitable for these conditions.

(Example: low impedance type 35V, 1000 $\mu F \times 2$ parallel for switching power supply)

(*) Use the actual equipment to confirm the actual ripple-voltage and ripple-current.

1-2-10. MOSFET gate circuits: R5, R6, D4

The MOSFET's gate circuits affect the MOSFET's loss and generate noise. The Switching speed for turn-on is adjusted using R5+R6, and for turn-off is adjusted using R5, via the drawing diode D4.

(Example: R5: 22 Ω / 0.25W, R6: 150 Ω , D4: SBD 60V, 1A)

In the case of DCM (Discontinuous Conduction Mode), switching-loss basically does not occur during turn-on, but occurs predominantly during turn-off. To reduce switching-loss when turned off, turn-off speed can be increased by reducing R5 value, but sharp changes in current will occur, which increases the switching-noise. Since there is a trade-off between loss (heat generation) and noise, measure the MOSFET's temperature rise and noise while it is assembled in the product, and adjust it as necessary.

Also, since a pulse current flows to R5, check the pulse resistance of the resistors being used.

1-2-11. AC start/stop voltage setting: R2, R3

The BM1Pxxx has a built-in brown IN/OUT function. The AC start/stop voltage is adjusted using R2 and R3.

When the ACMONI pin threshold values are 1.0V when rising and 0.7V when falling:

$$\text{AC ON voltage} = \frac{1.0\text{V}}{1.41} \times \frac{R2 + R3}{R3} \quad \text{AC OFF voltage} = \frac{0.7\text{V}}{1.41} \times \frac{R2 + R3}{R3}$$

R2 = 3.9MΩ and R3 = 39kΩ.

At that time, AC on-voltage = AC 72V and AC off-voltage = AC 50V.

1-3. EMI countermeasures

Confirm the following with regard to EMI countermeasures.

(*) Constants are reference values. Need to be adjusted based on noise effects.

- Addition of filter to input block
- Addition of capacitor between primary-side and secondary-side (C10: approximately Y-Cap 2200pF)
- Addition of capacitor between MOSFET's drain and source (C11: approximately 1kV, 10 to 100pF)
(When a capacitor has been added between the drain and source, loss is increased. Check for temperature rise and adjust accordingly)
- Addition of RC snubber to diode (C12: 500V 1000pF, R17: approximately 10Ω, 1W)

1-4. Output noise countermeasures

As an output noise countermeasure, add an LC filter

(L:10μH, C10: approximately 10μF to 100μF) to the output.

(*) Constants are reference values. Need to be adjusted based on noise effects.

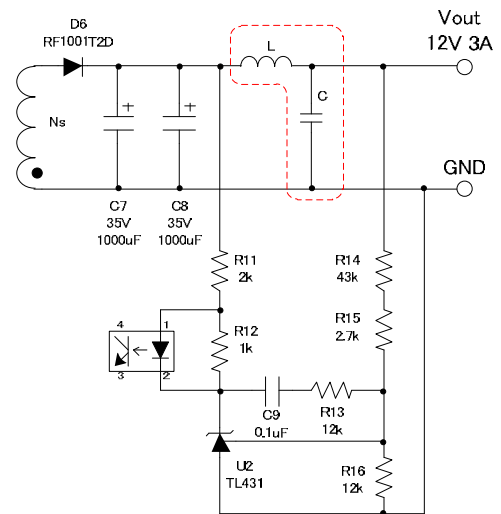

Figure 1-6. LC Filter Circuit

1-5. Proposed PCB layout

A proposed layout (example) for these circuits is shown in Figure 1-7.

- Single-sided board, lead component view
- Components in red are surface-mounted components

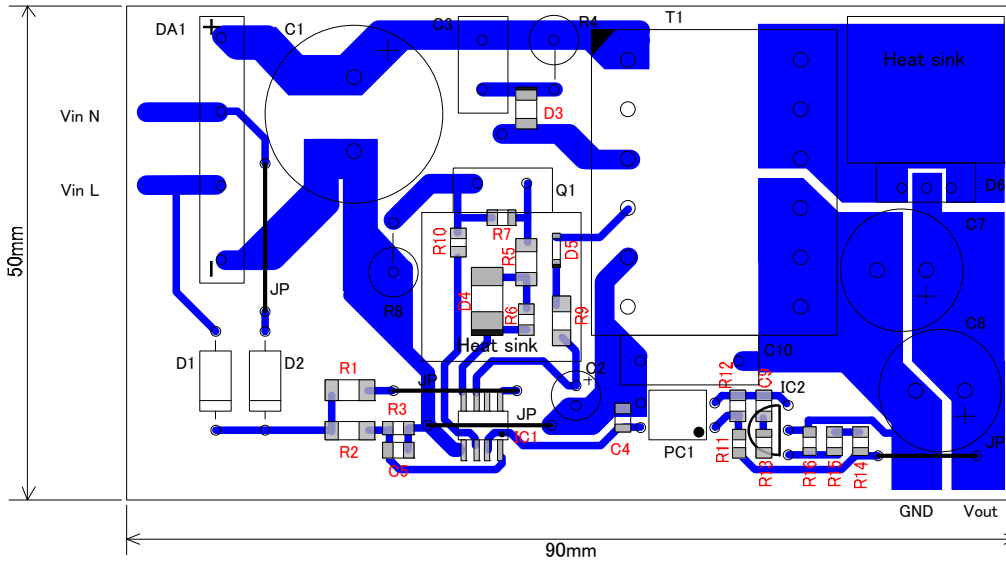

Figure 1-7. Proposed PCB Layout (Example)

Notes

- 1) The information contained herein is subject to change without notice.
- 2) Before you use our Products, please contact our sales representative and verify the latest specifications :
- 3) Although ROHM is continuously working to improve product reliability and quality, semiconductors can break down and malfunction due to various factors.
Therefore, in order to prevent personal injury or fire arising from failure, please take safety measures such as complying with the derating characteristics, implementing redundant and fire prevention designs, and utilizing backups and fail-safe procedures. ROHM shall have no responsibility for any damages arising out of the use of our Products beyond the rating specified by ROHM.
- 4) Examples of application circuits, circuit constants and any other information contained herein are provided only to illustrate the standard usage and operations of the Products. The peripheral conditions must be taken into account when designing circuits for mass production.
- 5) The technical information specified herein is intended only to show the typical functions of and examples of application circuits for the Products. ROHM does not grant you, explicitly or implicitly, any license to use or exercise intellectual property or other rights held by ROHM or any other parties. ROHM shall have no responsibility whatsoever for any dispute arising out of the use of such technical information.
- 6) The Products are intended for use in general electronic equipment (i.e. AV/OA devices, communication, consumer systems, gaming/entertainment sets) as well as the applications indicated in this document.
- 7) The Products specified in this document are not designed to be radiation tolerant.
- 8) For use of our Products in applications requiring a high degree of reliability (as exemplified below), please contact and consult with a ROHM representative : transportation equipment (i.e. cars, ships, trains), primary communication equipment, traffic lights, fire/crime prevention, safety equipment, medical systems, servers, solar cells, and power transmission systems.
- 9) Do not use our Products in applications requiring extremely high reliability, such as aerospace equipment, nuclear power control systems, and submarine repeaters.
- 10) ROHM shall have no responsibility for any damages or injury arising from non-compliance with the recommended usage conditions and specifications contained herein.
- 11) ROHM has used reasonable care to ensure the accuracy of the information contained in this document. However, ROHM does not warrant that such information is error-free, and ROHM shall have no responsibility for any damages arising from any inaccuracy or misprint of such information.
- 12) Please use the Products in accordance with any applicable environmental laws and regulations, such as the RoHS Directive. For more details, including RoHS compatibility, please contact a ROHM sales office. ROHM shall have no responsibility for any damages or losses resulting from non-compliance with any applicable laws or regulations.
- 13) When providing our Products and technologies contained in this document to other countries, you must abide by the procedures and provisions stipulated in all applicable export laws and regulations, including without limitation the US Export Administration Regulations and the Foreign Exchange and Foreign Trade Act.
- 14) This document, in part or in whole, may not be reprinted or reproduced without prior consent of ROHM.



Thank you for your accessing to ROHM product informations.
More detail product informations and catalogs are available, please contact us.

ROHM Customer Support System

<http://www.rohm.com/contact/>