

Compact Headphone Amplifier

BU7150NUV Evaluation Board Information

BU7150NUV-EVK-001(SE) / BU7150NUV-EVK-002(BTL)

● General

BU7150NUV is Audio Amplifier designed for Single-cell battery operated audio products ($V_{DD} = 0.93 \sim 3.5V$, at $T_a=0\sim 85^\circ C$). BU7150NUV can be selected in single-ended mode for stereo headphone and BTL mode for mono speaker operations. For BU7150NUV at $V_{DD} = 1.5V$, $THD+N = 1\%$, the output power is 14mW at $R_L = 16\Omega$ in single-ended mode and the output power is 85mW at $R_L = 8\Omega$ in BTL mode.

● Index

● General	1
● Index	1
● Conditions	1
● Circuit Diagram.....	2
● PCB layout	3
● Usage	4
● BOM List	5

● Conditions

Item	Symbol	Range		Unit
		BU7150NUV-EVK-001(SE) (Stereo Headphone Amplifier)	BU7150NUV-EVK-002(BTL) (Monaural Speaker Amplifier)	
Power Supply Voltage	V_{DD}	$+0.93 \sim +3.5$		V
Input Voltage	V_{IN}	$V_{SS}-0.3 \sim V_{DD}+0.3$		V
Load Impedance	R_L	$16 \geq$	$8 \geq$	Ω

This document is information of the evaluation board when we evaluated the device.
 This information will help you when designing your evaluation board.
 Notice, the evaluation board is not available for sale except BU7150NUV-EVK-001

●Circuit Diagram

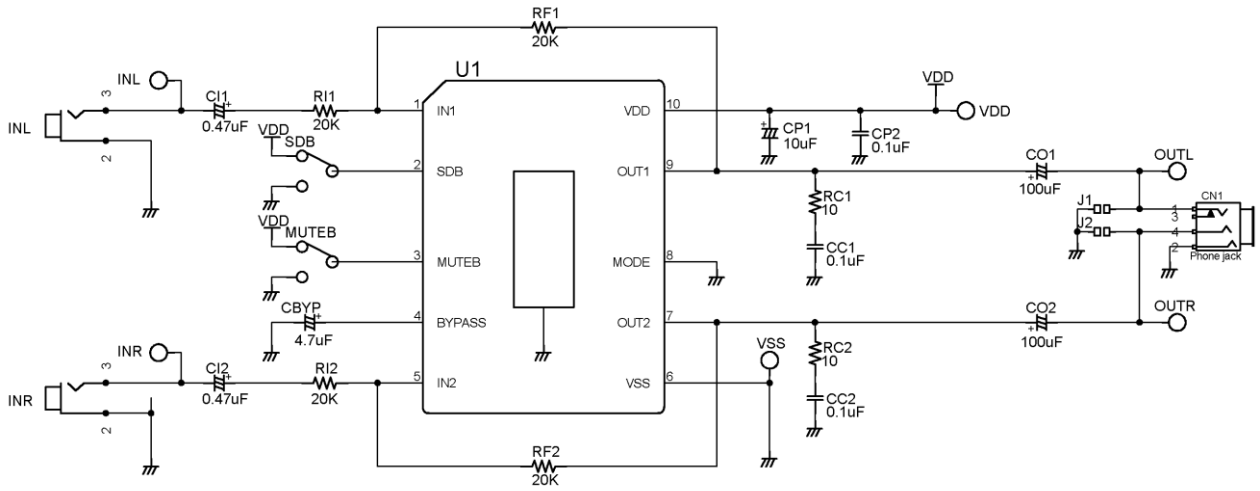

Note: Pin 3 of Phone jack open

SE mode (BU7150NUV-EVK-001)

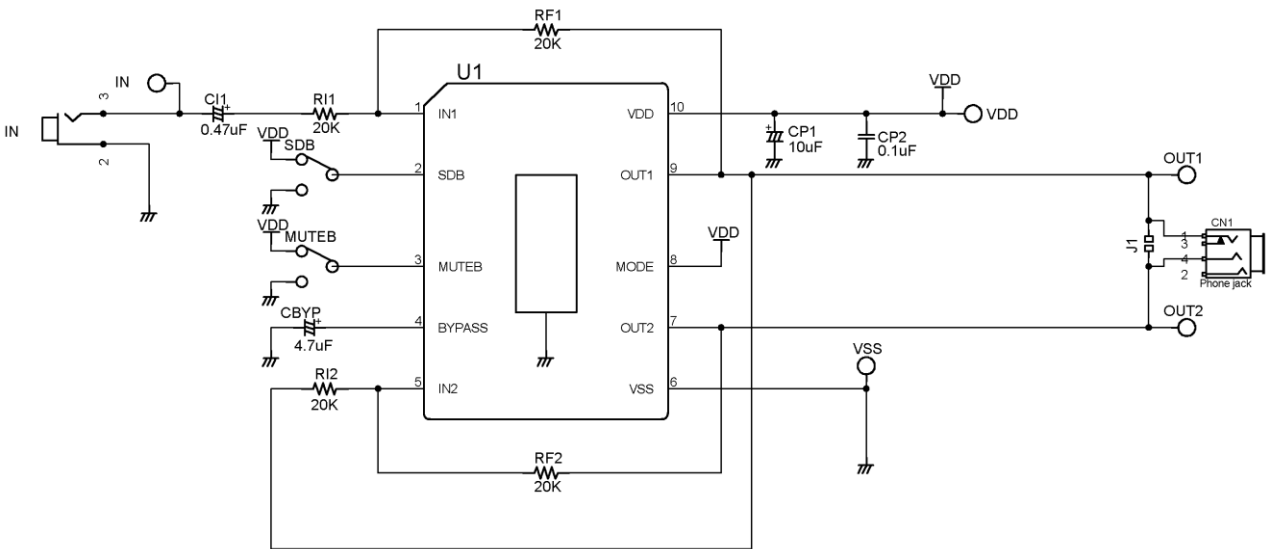

Note: Pin 2 and 3 of Phone jack open

BTL mode (BU7150NUV-EVK-002)

● Usage

- SE mode board (BU7150NUV-EVK-001)

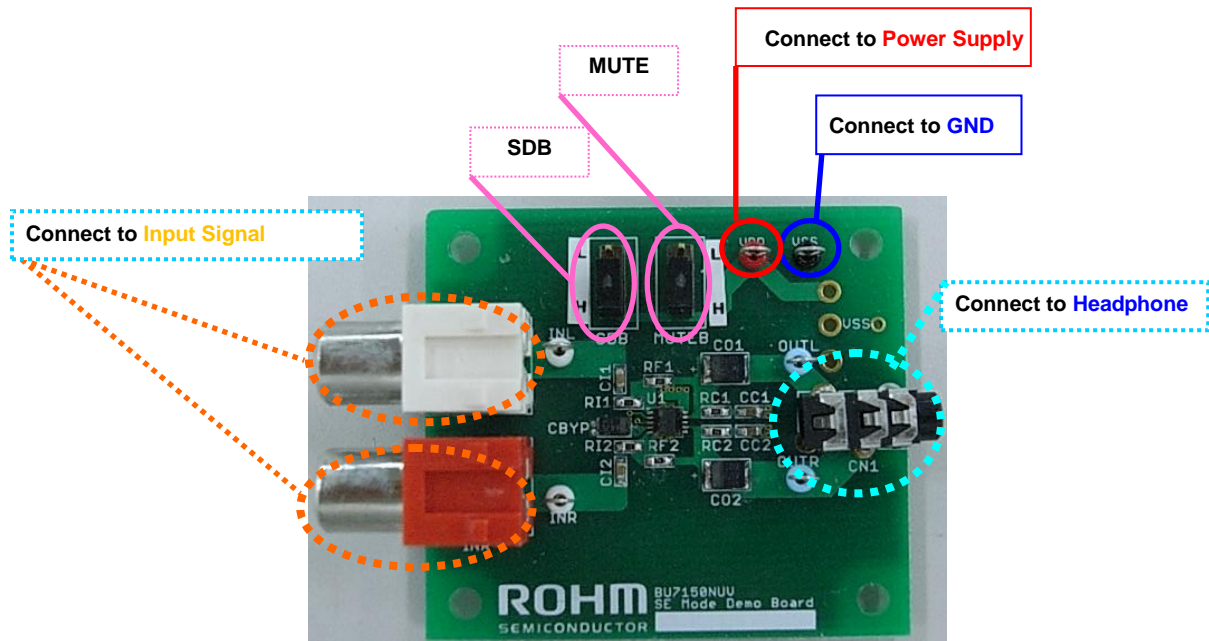

- BTL mode board (BU7150NUV-EVK-002)

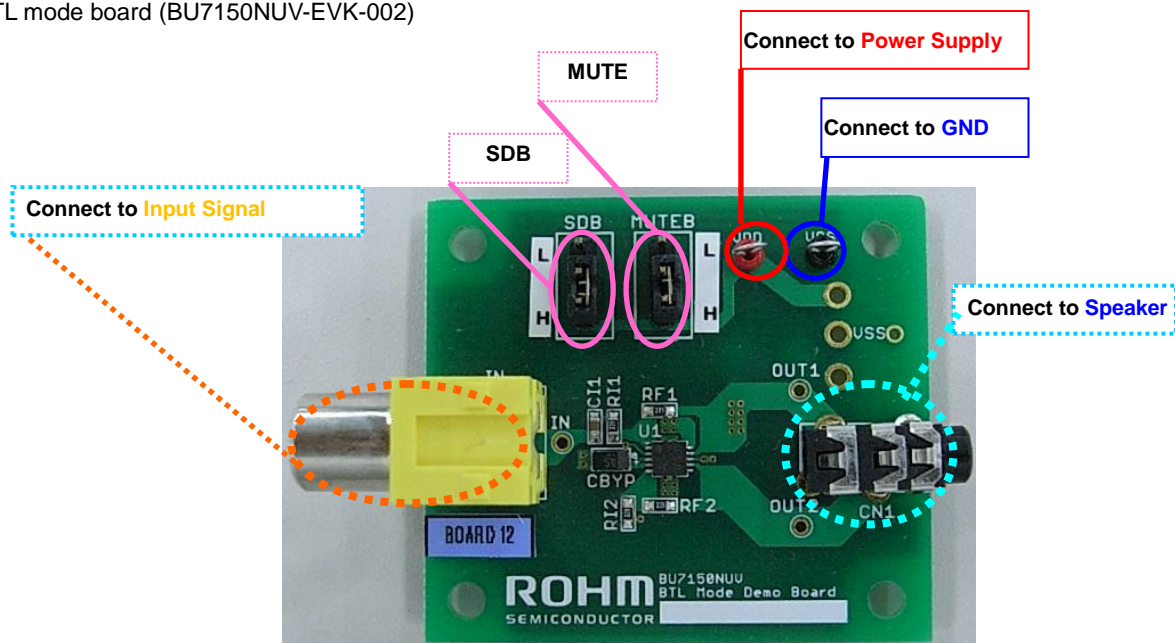

- ① Set the jumper of SDB & MUTE pin to L.
- ② Connect the Power Supply pin and GND pin.
- ③ Connect the audio source and Output device.
Output device of SE board : Headphone
Output device of BTL board : Speaker
- ④ Power On
- ⑤ Set the jumper pins to H
- ⑥ Input the audio source.

●BOM List

• SE mode board (BU7150NUV-EVK-001)

num	Part number	Type	Value	Package/ SMD size
1	U1	IC	—	VSON010V3030
1	CP1	Tantalum Capacitor	10 μ F	3216
3	CP2, CC1, CC2	Ceramic Capacitor	0.1 μ F	1608
2	CI1, CI2	Ceramic Capacitor	0.47 μ F	1608
1	CBYP	Tantalum Capacitor	4.7 μ F	3216
2	CO1, CO2	Tantalum Capacitor	100 μ F	3528
4	RI1, RI2, RF1, RF2	Resister	22k Ω	1608
2	RC1, RC2	Resister	10 Ω	1608
2	J1, J2	Solder Jumper	Open	—

• BTL mode board (BU7150NUV-EVK-002)

num	Part number	Type	Value	Package/ SMD size
1	U1	IC	—	VSON010V3030
1	CP1	Tantalum Capacitor	10 μ F	3216
1	CP2	Ceramic Capacitor	0.1 μ F	1608
2	CI1	Ceramic Capacitor	0.47 μ F	1608
1	CBYP	Tantalum Capacitor	4.7 μ F	3216
4	RI1, RI2, RF1, RF2	Resister	22k Ω	1608
2	J1	Solder Jumper	Open	—

Notes

- 1) The information contained herein is subject to change without notice.
- 2) Before you use our Products, please contact our sales representative and verify the latest specifications :
- 3) Although ROHM is continuously working to improve product reliability and quality, semiconductors can break down and malfunction due to various factors.
Therefore, in order to prevent personal injury or fire arising from failure, please take safety measures such as complying with the derating characteristics, implementing redundant and fire prevention designs, and utilizing backups and fail-safe procedures. ROHM shall have no responsibility for any damages arising out of the use of our Products beyond the rating specified by ROHM.
- 4) Examples of application circuits, circuit constants and any other information contained herein are provided only to illustrate the standard usage and operations of the Products. The peripheral conditions must be taken into account when designing circuits for mass production.
- 5) The technical information specified herein is intended only to show the typical functions of and examples of application circuits for the Products. ROHM does not grant you, explicitly or implicitly, any license to use or exercise intellectual property or other rights held by ROHM or any other parties. ROHM shall have no responsibility whatsoever for any dispute arising out of the use of such technical information.
- 6) The Products specified in this document are not designed to be radiation tolerant.
- 7) For use of our Products in applications requiring a high degree of reliability (as exemplified below), please contact and consult with a ROHM representative : transportation equipment (i.e. cars, ships, trains), primary communication equipment, traffic lights, fire/crime prevention, safety equipment, medical systems, servers, solar cells, and power transmission systems.
- 8) Do not use our Products in applications requiring extremely high reliability, such as aerospace equipment, nuclear power control systems, and submarine repeaters.
- 9) ROHM shall have no responsibility for any damages or injury arising from non-compliance with the recommended usage conditions and specifications contained herein.
- 10) ROHM has used reasonable care to ensure the accuracy of the information contained in this document. However, ROHM does not warrants that such information is error-free, and ROHM shall have no responsibility for any damages arising from any inaccuracy or misprint of such information.
- 11) Please use the Products in accordance with any applicable environmental laws and regulations, such as the RoHS Directive. For more details, including RoHS compatibility, please contact a ROHM sales office. ROHM shall have no responsibility for any damages or losses resulting non-compliance with any applicable laws or regulations.
- 12) When providing our Products and technologies contained in this document to other countries, you must abide by the procedures and provisions stipulated in all applicable export laws and regulations, including without limitation the US Export Administration Regulations and the Foreign Exchange and Foreign Trade Act.
- 13) This document, in part or in whole, may not be reprinted or reproduced without prior consent of ROHM.



Thank you for your accessing to ROHM product informations.
More detail product informations and catalogs are available, please contact us.

ROHM Customer Support System

<http://www.rohm.com/contact/>